

DEFRA

Department for
**Environment,
Food & Rural Affairs**

Guidance note for the Control of
Pollution (Oil Storage)
(England) Regulations 2001

DEFRA

Department for
**Environment,
Food & Rural Affairs**

Guidance note for the Control of
Pollution (Oil Storage)
(England) Regulations 2001

October 2001

Department for Environment, Food and Rural Affairs

Department for Environment, Food and Rural Affairs
Nobel House
17 Smith Square
London SW1P 5DU
Telephone 020 7238 3000
Internet service www.defra.gov.uk/

© Crown Copyright 2001

Extracts of this publication may be made for non-commercial in-house use, subject to the source being acknowledged.

Applications for reproduction should be made in writing to The Copyright Unit, Her Majesty's Stationery Office, St Clements House, 1-16 Colegate, Norwich NR3 1BQ.

Further copies of this guide are available from:

Department for Environment, Food and Rural Affairs
Free Literature
Wetherby
West Yorkshire
LS23 7NB
Tel: 0870 1226 236
Fax: 0870 1226 237

Published by the Department for Environment, Food and Rural Affairs.

© Crown copyright 2001. Printed in the UK October 2001 (01WLD0527) on paper comprising 75% post-consumer waste and 25% ECF pulp.

Product code PB5765

CONTENTS

Introduction	1
Who should read this guidance?	1
Purpose of this guidance note	1
Purpose of the Regulations	1
When do the Regulations come into force?	2
The Regulations	3
Scope and application of the Regulations (Regulations 1 and 2)	3
General requirements of the Regulations:	4
Responsibility for complying with the Regulations (Regulation 7)	4
Compliance dates and transitional provisions (Regulations 1 and 6)	4
Notices to minimise pollution risks in transitional cases (Regulation 7)	5
Right of appeal (Regulation 8)	6
Offences (Regulation 9)	6
Specific requirements:	6
Oil storage requirements – general (Regulation 3)	7
Structural integrity and maintenance of primary container (Regulation 3)	7
Safety zone and maintenance recommendations	7
Secondary containment system – bunds or drip trays (Regulation 3)	7
Primary containers – fixed tanks (Regulation 4)	9
Requirements for pipe work (Regulations 3 and 4)	10
Requirements for mobile bowsers (Regulations 3 and 5)	11
‘Best Practice’ Guidance	12
What to do in the event of an oil incident	14
Environment Agency and other contacts	15

ANNEX A	
Legislative Background	17
ANNEX B	
Regulatory and Environmental Impact Assessment	19
ANNEX C	
The Regulations	28
ANNEX D	
Environment Agency Oil Care Notice	34

Introduction

WHO SHOULD READ THIS GUIDANCE?

1. All organisations with members who have custody or control of oil storage facilities (including tanks, intermediate bulk containers, oil drums and mobile bowsers), with certain exceptions listed in paragraph 8. Those mainly affected are those storing oil above ground, with a 200 litre lower limit to storage capacity, on industrial, commercial and institutional (residential and non-residential) premises. A leaflet publicising the new Regulations and detailed guidance for users at individual sites is available from the Environment Agency ('the Agency') – see contact details at paragraph 47. Waste oil stores will be exempt from the Regulations, where waste oil is within the meaning of the *Waste Management Licensing Regulations 1994* (as amended). It is intended that the same requirements will be introduced in revisions to the waste oil storage provisions of those regulations in the near future.

PURPOSE OF THIS GUIDANCE NOTE

2. The purpose of this guidance is to provide background information and interpretation of the minimum legal standards in the *Control of Pollution (Oil Storage) (England) Regulations 2001* in more detail, and outline recommended 'best practice' measures that go beyond the requirements in the legislation. For example, the guidance distinguishes between the Regulatory requirements by using '**must**' and those recommendations that go beyond the statutory requirements by using '**should**'. The Regulations have been made under sections 92 and 219 of the *Water Resources Act 1991*. The Agency is responsible for enforcing these Regulations.
3. The guidance aims to explain in simple terms those points in the Regulations where additional interpretation would help, but does not repeat points which we consider are clearly described in the Regulations themselves. It is not a substitute for the Statutory Instrument and is not intended to have legal force. There is a duty both to avoid causing pollution and to comply with the Regulations. Variations in local conditions may mean that on some premises storing oil more stringent standards are needed to prevent pollution. You must make sure that your installations do not cause pollution.

PURPOSE OF THE REGULATIONS

4. There has been a rising trend in oil-related water pollution incidents in England in recent years, which have now stabilised at a high level. In 1999, oil accounted for 5,381 water pollution incidents in England, around 17% of all water incidents. Incidents were mainly due to leaks from unbunded tanks caused by inadequate storage facilities and equipment, vandalism and poor management/human error. Oil is a 'List I' substance within the meaning of the *EC Directives on Dangerous Substances (76/464/EEC)* and *Groundwater (80/68/EEC)* and the environmental damage caused as a result of these incidents can be significant and expensive to remediate. The UK Government is required by these directives to prevent pollution of the water environment from toxic substances rather than to treat pollution incidents after the event. The Regulations will contribute to the implementation of the EC directives by complementing and enhancing existing water

pollution controls in England. They should ensure that, in the future, contamination of controlled waters by oil is prevented or minimised. These Regulations were notified in draft to the European Commission in accordance with Directive 98/34/EC, which lays down a procedure for the provision of information in the field of technical standards and regulations.

5. The Regulations set minimum design standards for all new and existing above ground oil storage facilities, with the exceptions listed in paragraph 8. The key requirement is the provision of secondary containment (a 'bund' or 'drip tray') to ensure that any leaking or spilt oil cannot enter controlled waters. It is proposed that these requirements will come into force in three stages – see paragraph 7.
6. The objective of the Regulations is to reduce the number of oil-related water pollution incidents by the year 2005 by about half compared to 1999 levels. The Regulations affect all existing unbunded and inadequately banded tanks (approximately 60% of the overall existing stock), and any similar new stock. They should reduce the number of oil-related water pollution incidents by three-fifths, since the EA believe that unbanded and inadequately banded existing stock is 5 times more likely to have a pollution incident. This view is supported by a sample study carried out in 1993/94 by the predecessor of the Agency, which found that 60%-90% of oil-related pollution incidents resulted from poor storage facilities, eg unbanded tanks, leaking tanks and pipes, faulty valves, overfilling, vandalism, mobile bowsers, poor management and construction practices. In addition, some further reduction in incidents may be achieved from the impact of the proposals on inadequate equipment or management practices.

WHEN DO THE REGULATIONS COME INTO FORCE?

7. The Regulations come into force in three stages, which are explained in more detail at paragraph 10:
 - new oil stores are required to comply with the Regulations by 1 March 2002;
 - existing oil stores 'at significant risk' must comply by 1 September 2003;
 - all remaining existing oil stores must comply by 1 September 2005.

The Regulations

SCOPE AND APPLICATION OF REGULATIONS

(REGULATIONS 1 AND 2)

8. The Regulations apply to the storage of oil, as follows:
- (a) oil of any kind, including petrol, solvents, mineral oil, heating oil, lubricating oil, vegetable oil and waste oil except where waste oil is within the meaning of regulation 1(3) of the *Waste Management Licensing Regulations 1994* (as amended), in which case these requirements will be introduced in revisions to those Regulations. There are special additional requirements for 'flammable liquids' with a flash point of less than 32°C under the *Highly Flammable Liquids and Liquefied Petroleum Gases Regulations 1972*.
 - (b) in any kind of container which is being used and stored above ground and situated outside a building -meaning a fixed tank, intermediate bulk container, drum (oil drum or similar container used for storing oil) or mobile bowser – with a storage capacity which exceeds 200 litres. The Regulations do not apply to wholly underground oil storage facilities, such as those at petrol and diesel filling stations, as these may be adequately controlled under the *Groundwater Regulations 1998* and petrol storage is also subject to Health and Safety regulations. Guidance for these is set out in the Institute of Petroleum/ Association for Petroleum & Explosives Administration (IP/APEA) publication, '*Design, Construction, Modification and Maintenance of Petrol Filling Stations*'. Guidance for the *Groundwater Regulations 1998* is under development to define the environmental standards for new and existing underground petrol and diesel installations.
 - (c) on any premises, except in certain circumstances listed at (d) below. For example, the following premises must comply with the Regulations:
 - *industrial businesses*: small manufacturing premises such as food processing, textiles, paper and publishing, engineering, bricks and ceramics, metals, chemicals;
 - *commercial businesses*: such as shops, offices, theatres, hotels, restaurants, pubs, building and construction firms, motor garages, transport depots, bus stations;
 - *institutions (residential and non-residential)*: in the public and private sector, charities and voluntary groups, such as schools, hospitals, churches, prisons, libraries, public sector buildings, nursing homes; and occupiers of multi-residential dwellings whether privately or publicly owned blocks of flats or other dwellings fed oil from communal storage facilities.
 - (d) The Regulations exempt any premises:
 - used wholly or mainly as a *private dwelling* for domestic heating purposes, if the storage capacity of the container is of 3,500 litres or less. The number of oil-related incidents in such cases is relatively low and Building Control Regulations are expected to be implemented soon to control new private dwelling oil storage tanks. In addition, the Agency can use anti-pollution powers to require improvements of installations where pollution of controlled waters is likely to occur;

- used for *refining oil or for the onward distribution of oil to other places*. This includes sites where operations such as blending, filling and packaging are carried out, but does not include fuel installations for transport companies. The person having custody or control of the polluting matter will be required to implement pollution prevention measures of a standard agreed by the Agency. The standards set out in the IP publication, '*Design, Construction and Operation of Distribution Installations*' reflect what the Agency would normally consider to be the appropriate standards; and
 - *on any farm*. Agricultural fuel oil stores are covered by *The Control of Pollution Silage, Slurry and Agricultural Fuel Oil) Regulations 1991* (amended in 1997). The exemption for farms only include tanks used for agricultural purposes and not tanks being used for non-agricultural purposes.
- (e) The Regulations exempt any road or rail tanker used for the transport of oil. This includes road tankers used at airports and non-self propelled containers that are attached to road tankers.

GENERAL REQUIREMENTS OF THE REGULATIONS

Responsibility for complying with the Regulations (Regulation 7)

9. The Regulations require the person with custody or control of oil to carry out works, take precautions or other such action to minimise the risk of oil-related water pollution. It is this person that the Agency could serve with a transitional notice under Regulation 7 if, in the Agency's opinion, these risks have not been minimised. Disputes about who has custody or control would need to be resolved ultimately by the courts. The Government considers that the term would normally be understood as the person who has the right to control the polluting matter.

Compliance dates and transitional provisions (Regulations 1 and 6)

10. Regulation 1 sets out the compliance date for new oil storage facilities. Regulation 6 sets out the dates for compliance for existing oil storage installations, including mobile bowers and drums, under transitional provisions. It is proposed that the Regulations will come into force in three stages and, thereafter, operators will need to ensure that their oil storage facilities are maintained so that they comply with the proposed regulations at all times:
- **new facilities:** operators purchasing new oil storage tanks or facilities will need to comply with the proposed regulations six months after they have been introduced in Parliament, eg by 1 March 2002, to give them time to obtain planning permission;
 - **existing facilities at 'significant risk':** operators will need to comply within 2 years of the proposals being introduced in Parliament, eg by 1 September 2003. 'Significant risk' is defined as oil stores situated within 10 metres of inland freshwaters or coastal waters or within 50 metres of a well or borehole, though the Agency can issue a transitional notice where there may be other risks – see paragraph 12. If you need advice on whether your installation falls into this category, please contact the Agency for help – see paragraph 47;

- **remaining existing facilities (not at 'significant risk')**: operators will have to comply within 4 years of the proposals being introduced in Parliament, eg by 1 September 2005.
11. All installations newly replaced, constructed, substantially reconstructed or substantially enlarged by 1 March 2002, will need to comply with the requirements for existing facilities, by September 2005, with the exception of those at 'significant risk' (see paragraph 12 below). When an installation is substantially enlarged or substantially reconstructed, the Regulations apply immediately to the whole structure and not just the newly extended or reconstructed part. 'Substantially reconstructed' or 'substantially enlarged' will often mean that a tank has been replaced, moved or additional containers provided.
 12. Where existing facilities are at 'significant risk', they will need to be altered to comply by September 2003. It is for the operator to decide if an oil storage facility, or any of several oil storage containers, is at 'significant risk' – less than 10 metres away from any inland freshwater or coastal waters, or less than 50 metres away from a well or borehole. The Agency is able to advise upon request. However, the Agency may also inspect oil storage facilities to ensure that they comply with the Regulations and may decide that a facility or multi-facilities are at 'significant risk' for other reasons than those given in these Regulations; for example, the condition of the container or proximity to a route to a watercourse. In that case, the Agency has powers to issue a 'transitional notice' to require works to be carried out to minimise the risk to controlled waters (see Regulation 7).

Notices to minimise pollution risks in transitional cases (Regulation 7)

13. The Agency has powers to serve a transitional notice on the person having custody or control of oil stored in existing facilities, including those defined in the Regulations as being at 'significant risk'. The '*notice to minimise pollution risks in transitional cases*' can require the person to carry out works, or take precautions, or any other action that the Agency considers necessary to minimise pollution risks. The Agency can use a notice if it considers there are other 'significant risks' to controlled waters from oil storage facilities outside the definition at Regulation 7. The notice will give a time period within which any requirements must be complied with.
14. The minimum period of compliance following such a notice is 28 days following the date of service of the notice. The Agency has the right to withdraw the notice or may amend the compliance period with the consent of the person on whom the notice has been served. The Agency may extend the compliance period, for example, to take into account the time needed to obtain planning permission, or to arrange for contractors to do the work, or prevailing weather or site conditions. In issuing a notice the Agency will specify the improvements required to bring an installation up to an acceptable standard. The Agency may also modify the requirements of the transitional notice with the consent of the person on whom the notice has been served.
15. The Agency must also withdraw the notice or make alterations either to the compliance period or to the requirements, if directed to do so by the Secretary of State. This may occur if a person served with a notice appeals under Regulation 8.

Right of appeal (Regulation 8)

16. Regulation 8 includes a provision that allows a person to appeal to the Secretary of State against a transitional notice served by the Agency. If a person wishes to appeal against a notice served on her/him by the Agency, it must be done in writing within 28 days from the date on which the notice was served. Appeals in England should be addressed to the Secretary of State for Environment, Food and Rural Affairs. They should be sent to the Planning Inspectorate, PINS 5 Environment Procedure Group, 4th Floor Temple Quay House, 2 The Square, Temple Quay Bristol BS1 6PN Tel 0117 372 8812. If an appeal is made, the period for compliance with a notice will be extended until such time as the Secretary of State has determined the appeal.
17. The appeal must contain a statement of the appellant's reasons for appealing and the matters that he/she wishes the Secretary of State to take into account in determining the appeal, and it should also include the following documents:
 - A copy of the notice served on the appellant;
 - Any relevant correspondence;
 - A plan of the site showing the installation in question and its relation to watercourses, wells, boreholes and drains; and
 - A statement that the appellant is the person on whom the notice was served, or a statement from that person authorising someone to act on his/her behalf.
 - A statement indicating whether the appellant wishes to be in the form of a hearing or to be determined by written representations.
18. On determining the appeal, the Secretary of State may require the Agency to withdraw the notice or modify any of its requirements, or extend the period of compliance, or dismiss the appeal.

Offences (Regulation 9)

19. Regulation 9 states that a person with custody or control of any oil breaching the Regulations will be guilty of a criminal offence. On summary conviction in a Magistrates' Court a person breaching the Regulations will be liable to a fine not exceeding the statutory maximum (currently £5,000). If the case is heard in the Crown Court, on conviction on indictment, the penalty could be an unlimited fine.

SPECIFIC REQUIREMENTS

20. It is very important that you read the Regulations for the specific requirements you need to follow, as this guidance does not repeat all of the requirements. Instead, it focuses on a few issues that the Agency considers may need further clarification.

Oil storage requirements – general (Regulation 3)

21. Regulation 3 sets out the general requirements for the storage of oil. For example, the strength and structural integrity of the primary container, the requirements for the secondary containment system – a bund or drip tray – valves, filters, sight gauges, vent pipes or other ancillary equipment to the container. Guidance on these specific requirements are at paragraphs 22-30. Guidance on the specific requirements for the primary container is also under Regulation 4 at paragraphs 31-42, covering fixed tanks and mobile bowsers, including pipe work requirements.

Structural integrity and maintenance of primary container (Regulation 3)

22. Regulation 3(1) requires that oil must be stored in a container of sufficient strength and structural integrity to ensure that in normal circumstances it is unlikely to leak or burst. This means that the container is expected to last until replacement, with proper maintenance, without causing, or being at risk of causing, pollution. It is recommended that you purchase a fixed container expected to last for a minimum of 20 years before it needs to be replaced. Note, plastic tanks are not suitable for the storage of flammable liquids. When in use, containers must at all times meet the performance standards laid down. For example, the requirement for an impermeable bund base and walls at Regulation 3(2)(c) must be met. Regular inspection by qualified inspectors of your containers will ensure that potential defects are found and corrected before causing problems and are key to ensuring that containers do not cause pollution. More advice is contained in the OFTEC information note TI/120 '*Oil Storage Inspection and Maintenance*'.

Safety zone and maintenance recommendations

23. It is recommended that, where practicable, primary containers (whether tanks, intermediate bulk containers, mobile bowsers or drums) should not be constructed or situated outside a building within 50 metres of any borehole or 10 metres of any inland freshwaters and coastal waters that any leaking oil could enter. This includes rivers, lakes, reservoirs and smaller watercourses such as streams and ditches as well as perforated drainage pipes. It is recognised that this is not always practicable, for example, where primary containers are located in boat yards or in coastal locations. However, in these cases, or where it is difficult to fit a bund, it is important to seek advice from the Agency. Note, the storage of flammable liquids should be in steel tanks and is subject to Health and Safety Executive guidance HS(G)50 '*The storage of flammable liquids in fixed tanks*'. Routine maintenance of the primary and secondary containment systems to prevent any risk of water pollution is recommended to ensure the standards proposed in the Regulations are met at all times, as well as a more detailed annual inspection and service. Maintenance proposals should not be onerous as storage tanks have few mechanical features.

Secondary containment system – bunds or drip trays (Regulation 3)

24. Regulation 3(2) sets out the requirements for the secondary containment system. A secondary containment system is a further container to catch any oil leaking from the primary container or its ancillary pipework and equipment. This may take the form of a 'bund' used for primary containers, including multiple drums or a drum storage area, or a 'drip tray' for a mobile bowser or drum or any other containment system for preventing oil which is no longer in the container from escaping from the place where it is stored. Further guidance on bunds around oil tanks and mobile bowsers is below. For oil drums, Regulation 3(5) requires that a drip tray is used with a capacity of not less than 25% of the

drum's storage capacity or, if there are several drums situated together a secondary containment system 25% of the aggregate storage capacity.

25. The Regulations provide that a bund may be a conventional in-situ constructed bund or that, alternatively, a proprietary prefabricated tank system designed to provide an equivalent level of pollution prevention may be used. Regulation 3(2) (a) requires that the capacity of the bund must be calculated as not less than 110% of the container's total storage capacity, irrespective of whether storage is in fixed or mobile containers (except for oil drums where Regulation 3(5) applies). Under the Regulations, bunds are required for each individual container, or for a group of containers, as long as the total capacity of the bund is not less than 110% of the largest container in the system or 25% of the aggregate total capacity of the containers, whichever is the greater. It is recommended that the bund wall has a minimum height of 150mm to allow for rainfall and fire fighting foam.
26. An alternative method for calculating bund sizes has been devised as a result of research undertaken by the Construction Industry Research and Information Association (CIRIA). This is a more rigorous approach and may be more appropriate for sensitive sites. For further details, please see the Environment Agency's guidance PPG2. More sensitive sites may also wish to consider the potential escape of oil beyond a bunded area by 'jetting', which can be minimised by keeping the container as low as possible or increasing the height of the bund wall. More information is contained in the CIRIA report (R163) '*Construction of bunds for oil storage tanks*'.
27. Regulation 3(2) (b)-(e) requires that the bund must be positioned to minimise any risk of damage by impact as far as reasonably practicable. The bund and the base of the storage area must be impermeable to water and oil and must remain so with proper maintenance. It is recommended that reinforced materials are used for bund wall construction and there should not be a damp proof course. Bunds, tanks and pipework should be inspected regularly for signs of damage, eg missing bricks in walls, broken pipes and water in the bund, and checked visually by the operator at least weekly. A more detailed annual check by a trained operator, eg in the OFTEC registered scheme, is also recommended to ensure there is no corrosion, mechanical damage or oil leaks. The bund base and walls must not be penetrated by any valve, pipe or other opening which is used for draining the system, and when a fill pipe or draw off pipe must pass through the bund base or wall, the hole must be carefully sealed to prevent oil escaping.
28. Under Regulation 3(3), every part of the oil storage installation must be within the bund including valves, filters, sight gauges, vent pipes or other equipment ancillary to the container (other than a fill pipe or draw off pipe or, if the oil has a flashpoint of less than 32°C, a pump). A filter or isolating valve fitted to protect the draw off pipe or down stream equipment, but not the container or its contents, is not considered to be ancillary to the container. But if possible these should be located within the secondary container. Top outlet draw off pipes are preferred. It is recommended that valves should be as resistant to unauthorised interference and vandalism as possible, with lockable or removable hand wheels. It is also recommended that they are durable and 'fit for purpose', and are marked to show whether they are open or closed, kept locked when not in use and fitted with a blanking cap or plug. A notice should be displayed requiring that valves be kept locked when not in use and that trigger guns and hoses be stored within the bund or suitable secure cabinet, which is locked shut when not in use (see paragraph 40).
29. As the bund will contain no gravity outlet or drain, it will be necessary to have a method of removing contaminated rainwater and spilt oil to avoid pollution. Consideration should be given to the use of enclosed proprietary prefabricated storage systems or roofing over the

storage area to prevent rain getting into the bund except for petrol and flammable liquids, which should be stored in accordance with Health and Safety Executive guidance HS(G)50. If oil, or a mixture of oil and water, collects in a bund the person with custody or control of the oil will be responsible under the Regulations for removing the liquid and disposing of it safely and in accordance with the *Waste Management Licensing Regulations 1994*. It is recommended that the water be collected in a sump formed in the base of the bund and removed using a manually operated pump or by baling. A fail-safe automatic pumping system can be used, which monitors the oil and water interface, and automatically activates to pump out only water.

30. A proprietary prefabricated tank system is equivalent to a bund with a brick wall, and is especially useful where it is impractical to build a bund wall. There are a number of such systems available incorporating a storage tank with a bund. Some of these may not fully satisfy the requirements of the Regulations. It is, therefore, advisable to obtain written confirmation from the supplier that the requirements are met. CIRIA has completed a '*Review of Proprietary Prefabricated Bunded Oil Storage Tank Systems*'. Such systems are not suitable for petrol and flammable liquids if fabricated from plastic.

Primary containers – fixed tanks (Regulation 4)

31. Regulation 4 sets out the specific requirements for fixed tanks, including intermediate bulk containers. All new (including under construction, substantially enlarged or substantially reconstructed) and existing oil storage tanks will be expected to meet the standards set out in Regulation 4 within the compliance dates at Regulation 1 for new tanks and Regulation 6 for existing tanks.
32. A primary container is defined in Regulation 1(2) as meaning a fixed tank, drum, mobile bowser, intermediate bulk container or other container used for the storage of oil. A double skinned tank is a tank with another skin with a small gap between the two. The attached pipework and ancillary equipment is not provided with secondary containment and therefore double skinned tanks should be treated as primary containment and should be protected by a suitable bund. Proprietary prefabricated tank systems have an additional containment facility for attached ancillary equipment and pipework and so are considered to provide both primary and secondary containment.
33. To ensure compliance with the Regulations, it is recommended that storage tanks should be type tested to a recognised standard and produced to that standard under a quality assurance system complying with ISO 9001. Steel tanks should comply with BS799, Part 5 (Reference 5) or OFS T200. Polyethylene tanks should conform to OFS T100 (Reference 1). It is recommended that tank installers are registered to ISO 9002.
34. Steel tanks must be protected against corrosion. Water from within the tanks should be drawn off regularly and suitable frost resistant valves used to prevent damage in freezing conditions. Where possible, it is recommended that a minimum distance of 750mm between the tank and the bund wall and 600mm between the tank and base is maintained, so tanks can be inspected externally for corrosion or leaks.
35. It is also recommended that tanks be marked with the product type and tank capacity. The Institute of Petroleum operate a colour coding system for different grades of oil for use by delivery drivers. A notice giving details on safe delivery procedures and what to do in an emergency should be sited at the delivery point. The Agency can supply a self-adhesive notice to use for this purpose, see Annex D for an example.

36. It is recommended that an adequate means of measuring the quantity of oil and an overflow alarm should be provided – see OFTEC standard OFS E105. Sight gauge tubes, if used, must be well supported and fitted with a valve. This must be automatically in the off position except when readings are being taken. When dial gauges are fitted, these should be in a prominent position and regularly checked for accuracy. A standard has been developed in OFS T103 – ‘Gauges for use with oil supply tanks’, available from OFTEC. If a dipstick is used it should be suitably calibrated for the tank.

A diagram showing the required arrangements for a fixed oil storage tank is below.

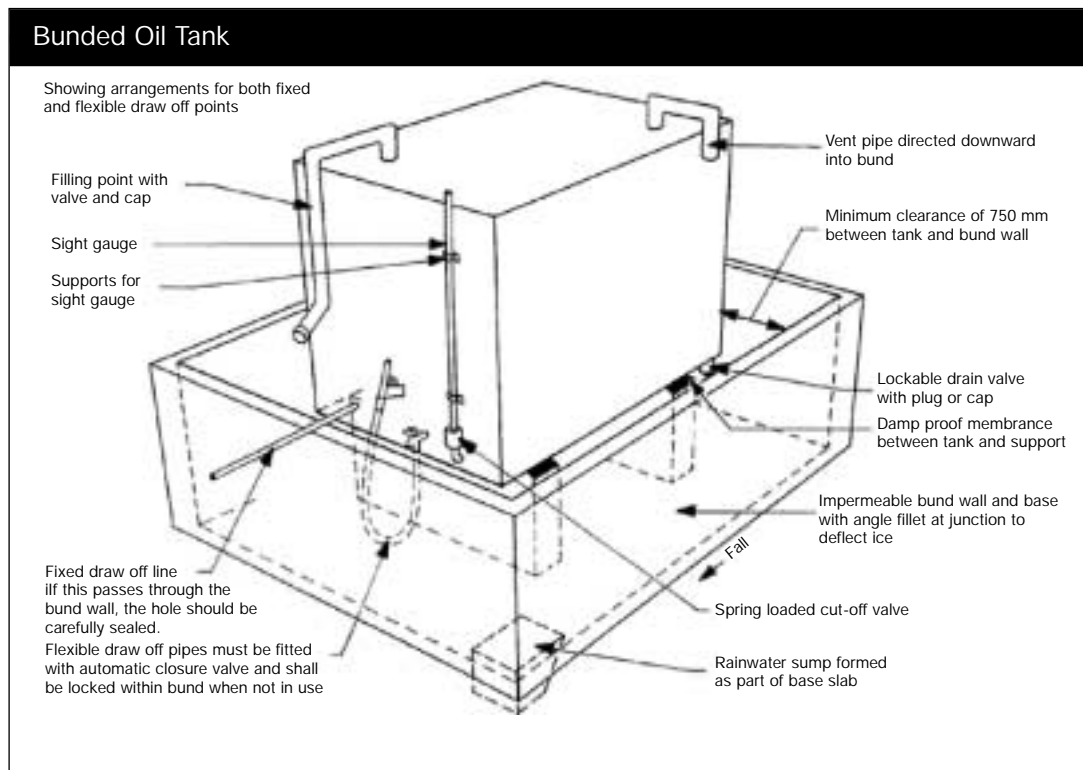

Requirements for pipe work (Regulations 3 and 4)

37. It is worth noting that, in Regulation 4, above ground pipe work must be well supported, protected from corrosion and in a position where risk of damage is minimised. If overhead pipes cross open waters they should have no mechanical joints. Underground pipes are not recommended, but where used, must have no mechanical joints (except at manholes). Regulation 4(3) (b) (ii) requires that underground pipes must be protected from physical damage, for example, from mechanical damage, excessive surface loading and ground movement or disturbance. This will protect the environment. It is recommended that there is access for inspection purposes and that the route of underground pipe work should be clearly marked. OFTEC Technical Note TI/134 offers advice on installing oil supply pipes underground. Regulation 4(3) (b) (iii) requires that underground pipes must have adequate facilities for detecting leaks, such as alarms and should meet with EC leak detection standard EN 13160-1 to 7. Inspections for leaks and of leak detection devices should be carried out annually and by a qualified person.
38. *Fill pipes:* Remote fill points are not recommended, but where unavoidable they should conform to BS799: Part 5 (Reference 5) or OFS T100 as appropriate. Where a facility has a remote filling point and the vent pipe cannot be observed directly during the filling operation, a fail safe overflow prevention device must be used during delivery. If the fill point is external to the bund, a drip tray must be used.

39. It is recommended that separate fill pipes are provided for each tank, unless the tanks are interconnected by a balance pipe of greater flow capacity than the fill pipe. The fill pipes should have a 50mm diameter threaded connection and should be clearly marked with the product type, tank capacity and a tank number where more than one tank is involved. It is also recommended that fill pipes be fitted with a suitable lockable cap with chain.
40. *Draw off pipes:* Where oil from the tank is dispensed through a flexible pipe which is permanently attached to the tank, under Regulation 4(6), the pipe must be kept within the bund when not in use. Alternatively, the pipe may be contained within a secure cabinet with a drip tray. The draw off pipe should have a cut-off valve or lockable valve where it leaves the container, which should be locked when not in use.
41. *Vent Pipes:* In addition to compliance with Regulation 4(8), it is recommended that air vent pipes should be positioned so they can easily be seen during delivery. They should be well supported and not smaller than the inlet pipe.

Requirements for mobile bowsers (Regulations 3 and 5)

42. Note that mobile bowsers excludes road tankers. Under Regulation 5(3) (b), where the pump or valve is contained in a cabinet, the cabinet should also be locked shut when not in use. Under Regulation 5, sight gauges must be fitted with a valve or tap, which must be shut when not in use. Under Regulation 3, mobile bowsers must be bunded or have a suitably sized drip tray receptacle fitted underneath when in use/out on site. Sight gauge tubes, if used, must be well supported and fitted with a valve. This must be automatically in the off position except when readings are being taken. When dial gauges are fitted, these should be in a prominent position and regularly checked for accuracy.

‘Best Practice’ Guidance

43. The following ‘best practice’ guidance on above ground oil storage installations is available, but does not have statutory force:

(a) **‘Pollution Prevention Guidelines: PPG 2 – Above Ground Oil Storage Tanks.’**

This guidance is produced jointly by the Environment Agency for England and Wales, the Scottish Environment Protection Agency and the Environment and Heritage Service in Northern Ireland. These guidelines differ in places from these Regulations as they describe best practice, whereas the Regulations set minimum standards. Whilst we would recommend that best practices are adopted where possible, you are only legally required to adopt the minimum standards. Other Pollution Prevention Guidance notes of interest are:

- PPG 1 – General Guide to the Prevention of Water Pollution
- PPG 2 – Above Ground Oil Storage Tanks
- PPG 3 – Use and Design of Oil Separators in Surface Water Drainage Systems
- PPG 8 – Safe Storage and Disposal of Used Oils
- PPG 11 – Preventing Pollution on Industrial Sites
- PPG 15 – Retail Stores
- PPG 16 – Schools and Educational Establishments
- PPG21 – Pollution Incident Response Planning
- PPG 26 – Drum and Intermediate Bulk Container Storage
- Masonry bunds – for construction
- Concrete bunds – for construction

The Agency will offer help and guidance in complying with the Regulations, ‘best practice’ guidance or otherwise preventing pollution.

(b) **British Standards Institution** – BS799 Part 5 (Reference 5) sets a standard for steel tanks. BS5410 Part I: 1997 is a Code of Practice for Oil Firing Installations up to 45kW output capacity for space heating and hot water purposes. BS5410 Part 2 (1978) covers oil firing installations of 44kW and above and Part 3 (1978) covers installations for furnaces, kilns, ovens and other industrial purposes. The recommendations in the British Standards differ in places from the minimum standards laid down in the Regulations.

(c) **OFTEC** (Oil Firing Technical Association for the Petroleum Industry) – with OFS T100 (Reference 1) sets a standard for polyethylene tanks. Technical Information sheets TI/133 and TI/134 cover the risk of environmental damage from domestic oil

storage tanks and installing oil supply pipes underground respectively. OFTEC technical information sheet TI/120 '*Oil Storage Inspection and Maintenance*' is also available. OFS T103 – '*Gauges for use with oil supply tanks*' – gives information on standards for sight gauges. A further standard has been developed for overfill alarms and steel tanks, OFS T200. The OFTEC Driver Training Programme will provide training to registered tanker drivers in accordance with their Code of Practice OCP/2-D to help ensure compliance with the Regulations.

- (d) **Institute of Petroleum** – produces Environmental Guidelines for Petroleum Distribution Installations.
- (e) Technical advice on constructing installations is also available from companies supplying equipment. It is recommended that OFTEC accredited companies are used to install tanks, deliver oil and to carry out inspections at regular intervals.
- (f) **FPS** (Federation of Petroleum Suppliers Ltd) – has adapted the current national standard for Driver Training for Carriage of Dangerous Goods by Road, NVQ Level 2, for the oil distribution industry.
- (g) **CIRIA** (Construction Industry Research and Information Association) has completed a '*Review of Proprietary Prefabricated Bunded Oil Storage Tank Systems*', which has recommendations and best practice guidelines for use by manufacturers and the oil industry on these type of oil storage systems. The review also looks at causes of pollution from oil storage tanks and best practice prevention measures. The '*Construction of bunds for oil storage tanks*' (Report 163) contains guidance on the design and construction of bunds.
- (h) **UKAS** (United Kingdom Accreditation Service) UKAS is the sole national body for the assessment and accreditation of conformity assessment bodies whose activities include sampling, testing, calibration, inspection and product, personnel and system certification.

What to do in the event of an oil incident

44. Risks of a spillage should be considered and a contingency plan prepared. A stock of materials such as sand or commercially available absorbent materials, gully seals and booms should be held on site to deal with spillages. If a spill does occur, immediate action should be taken to contain it and to prevent it from entering any drains or watercourses. Do not hose the spillage down or use any detergents.
45. There is a high risk of a spill occurring during a delivery. It is therefore essential to ensure that there is sufficient capacity in the tank before a delivery, that the secondary containment system will contain any spill due to overfilling, and that where there are multiple tanks the delivery is made to the correct tank.
46. If a spillage does occur, contact the Agency immediately: the **Emergency Hotline** telephone number is 0800-807060. Agency staff may be able to provide advice and assistance, which could prevent a spill ending in pollution. This could help both reduce the impact of the pollution and the cost of cleaning it up.

Environment Agency and Other Contacts

47. For help interpreting these guidelines and the Regulations, please contact the Environment Agency at 0845-933 3111.
48. You may also wish to get in touch with the following organisations mentioned in this guide:

Environment Agency

Head Office (or contact the Regional Office address)

Rivers House

Waterside Drive

Aztec West

Almondsbury

Bristol

BS12 4UD

Tel: 01454-624400

Fax: 01454-624409

For help with these Regulations: 0845-933 3111

Emergency Hotline: 0800 807060

Oil Firing Technical Association for the Petroleum Industry (OFTEC)

Century House

100 High Street

Banstead

Surrey

SM7 2NN

Tel: 01737 373311

Fax: 01737 373553

Construction Industry Research and Information Association (CIRIA)

6 Storey's Gate

Westminster

London

SW1P 3AU

Tel: 020 7222 8891

Fax: 020 7222 1708

Institute of Petroleum

61 New Cavendish Street

London

W1M 8AR

Tel: 020 7467 7100

Fax: 020 7255 1472

British Standards Institution

British Standards House

389 Chiswick High Street

London

W4 4AL

Tel: 020 8996 9000

Fax: 020 8996 7400

UK Accreditation Service (UKAS)

21-47 High Street

Feltham

Middlesex

TW13 4UN

Tel: 020 8917 8400

Fax: 020 8917 8500

British Oil Spill Control Association

30 Great Guildford Street

London

SE1 0HS

Tel: 020 7928 9199

Fax: 020 7928 6599

ANNEX A

Legislative background

The Control of Pollution (Oil Storage) (England) Regulations 2001 set minimum standards. They do not change other legislation under which it is an offence to cause water pollution. There is a duty both to avoid causing or permitting water pollution and to comply with the general and specific requirements in the Regulations. Variations in local conditions may mean that on some sites more stringent standards are needed to prevent pollution. You must ensure that your installations do not cause or permit water pollution.

The oil storage regulations will contribute to the implementation of the *EC Directives on Dangerous Substances (76/464/EEC)* and *Groundwater (80/68/EEC)* by complementing and enhancing existing water pollution controls in England and Wales. The regulations apply minimum prescriptive standards on a blanket basis to all premises storing oil in above ground fixed or mobile tanks or facilities. This means that the Environment Agency (EA) will not need to make a special visit to individual sites to assess risks, but will enforce the regulations during routine visits and thus reduce resource burdens. Underground oil storage facilities, such as those at petrol and diesel filling stations, will be controlled under the *Groundwater Regulations 1998* to enable the EA to complement existing Health and Safety legislation at such sites. A statutory code of practice for the Groundwater Regulations is under development to define the environmental standards for new and existing underground petrol and diesel tanks.

The EA has a number of pollution control powers to protect the water environment. These are listed below.

DISCHARGE CONSENTS

Under the *Water Resources Act 1991*, discharges to controlled waters, which include rivers and groundwaters, are authorised by 'discharge consents' from the EA. If there is no consent, or consents are exceeded, by 'causing or knowingly permitting any poisonous, noxious or polluting matter to enter controlled waters', the polluter is liable to prosecution under section 85 of the 1991 Act. This criminal offence applies not only to specific 'point source' discharges, but also to spillages, leaks and 'diffuse source' discharges, such as leaks and spills of oil.

WORKS NOTICES

The *Anti-Pollution Works Regulations 1999* came into force in April 1999 to enable the EA to serve 'works notices' on polluters or potential polluters requiring them to carry out works or operations to remedy or prevent pollution of controlled waters. Works notices provide an additional regulatory tool for the EA to help prevent pollution incidents. The works notice powers under section 161A of the *Water Resources Act 1991* were inserted by the *Environment Act 1995*. They represent a more direct regulatory measure for the EA than its powers under section 161 of the 1991 Act to carry out anti-pollution works itself and then recover costs from the person responsible, or where no person can be found on whom to serve a works notice.

GROUNDWATER NOTICES

The *Groundwater Regulations 1998*, which were brought into force on 1 April 1999, give the EA (in England and Wales) and Scottish Environment Protection Agency (in Scotland) powers to help them prevent leaks and spillages from activities (including mineral oils and hydrocarbons) that may cause a direct or indirect discharge of List I or II substances into groundwaters. The Regulations introduce controls over disposals (or tipping for the purposes of disposal) to land which could pollute groundwater, prohibit discharges of List I substances (such as oil) to groundwater, and provide powers for the environment agencies to control activities which may pollute groundwater. The Regulations require that any disposals of listed substances to land be authorised in advance by the environment agencies. Such authorisation can only be given following a prior investigation into matters such as the hydrogeological conditions of the area concerned. Authorisation may be given subject to conditions, or withheld, where this is necessary to prevent the entry of List I substances into groundwater or its pollution by List II substances. The environment agencies also have powers to issue notices to prohibit or control activities in or on land which may lead to an indirect discharge of listed substances to groundwater. Those observing statutory codes of practice will not normally be served with such notices.

Most oil and hydrocarbon related activities, including petrol filling stations, will not require prior investigation and authorisation under the *Groundwater Regulations* as there is no direct discharge or disposal into groundwater requiring a discharge consent. However, activities which involve the storage and handling of potentially polluting oil and petrol substances must be controlled to prevent leaks and spills that could allow List I substances to enter groundwater. The EA is placed under a duty (under regulation 19) to prevent pollution by serving a 'groundwater notice' prohibiting the activity, or allowing it to continue subject to conditions, where the EA considers the activity, such as the storage of fuels above or below ground, may result in an indirect discharge of the listed substance to groundwater. Such notices will not normally be served on those observing a statutory code of practice, but could be issued to unsatisfactory oil storage facilities, including petrol filling stations. Failure to comply with conditions in a notice or an authorisation is an offence under the *Water Resources Act 1991*, carrying penalties.

FARM REGULATIONS

The Control of Pollution (Silage, Slurry and Agricultural Fuel Oil) Regulations 1991 (as amended in 1997) made under Section 92 of the *Water Resources Act 1991* apply to agricultural fuel stores as well as to silage making and storage and slurry storage systems. For agricultural fuel oil stores, the Regulations set minimum standards for stores constructed after September 1991, where over 1,500 litres of fuel are stored. Anyone guilty of breaching the Regulations is guilty of a criminal offence and may be subject to a fine.

BUILDING REGULATIONS

The Building Regulations 1991 may be amended to include provisions for pollution prevention measures at new build private dwellings, similar to the new oil storage regulations. The EA can use existing anti-pollution powers to tackle individual existing private dwellings heating oil storage tanks where pollution of controlled waters is likely to occur.

ANNEX B

Regulatory and Environmental Impact Assessment

The Control of Pollution (Oil Storage) (England) Regulations 2001

TITLE

1. The Control of Pollution (Oil Storage) (England) Regulations 2001.

PURPOSE AND INTENDED EFFECT OF THE MEASURE

(i) Identify the issue and objective

2. There has been a rising trend in oil-related water pollution incidents in England in recent years, which have now stabilised at a high level. In 1998, oil accounted for 4,940 water pollution incidents, around 30% of all water pollution incidents. Incidents were mainly due to leaks from unbunded tanks, inadequate storage facilities and equipment, vandalism and poor management/human error. Oil is considered to be a 'List I' substance within the meaning of the *EC Directives on Dangerous Substances (76/464/EEC) and Groundwater (80/68/EEC)* and the environmental damage caused as a result of these incidents can be significant and expensive to remediate. The UK Government is required by the directives to prevent pollution of the water environment from toxic substances rather than to treat pollution incidents after the event. The proposed regulations would contribute to the implementation of the EC directives by complementing and enhancing existing water pollution controls in England. They should ensure that, in the future, contamination of controlled waters by oil is prevented or minimised.
3. The proposed regulations would set design standards for new and existing above ground oil storage facilities, mainly affecting the industrial, commercial and institutional sectors. The key requirement would be provision of secondary containment (a 'bund' or 'drip-tray') to ensure that any leaking or spilt oil cannot enter controlled waters. The proposals would come into force in three stages following the introduction of the proposed regulations in Parliament:
 - new tanks would have to comply within six months (in 2002);
 - existing tanks at 'significant risk' (defined as facilities which are located within 10 metres of a watercourse of 50 metres of a borehole or well – though the EA would have flexibility to issue a 'transitional notice' where there were other circumstances which it considered posed a significant risk) would have to comply within two years (in 2003); and
 - remaining existing tanks would have to comply within four years (in 2005).

4. The objective of the proposed regulations would be to reduce the number of oil-related water pollution incidents by the year 2005 by about 2,700 per annum compared to 1998 levels. The proposals would mainly affect industrial, commercial, institutional (residential and non-residential) premises with new and existing above ground oil storage facilities in England and would affect all such existing unbunded and inadequately banded tanks (approximately 60% of the overall existing stock), and any similar new stock. It should reduce the number of oil-related water pollution incidents by three-fifths, since the EA believe that unbanded and inadequately banded existing stock is 5 times more likely to have a pollution incident. This view is supported by a sample study carried out in 1993/94 by the predecessor of the EA, which found that 60%-90% of oil-related pollution incidents resulted from poor storage facilities, eg unbanded tanks, leaking tanks and pipes, faulty valves, overfilling, vandalism, mobile plant, poor management and construction practices. In addition, some further reduction in incidents may be achieved from the impact of the proposals on inadequate equipment, vandalism or management practices.

(ii) Risk assessment

5. Oil spills are objectionable aesthetically but, more seriously, place all aquatic organisms at risk. Oil forms a film on the surface of rivers and lakes, which prevents or greatly reduces the rate at which atmospheric oxygen can be absorbed into water. This causes distress and even death to aquatic life. Oil may adhere to the feathers and coats of birds and animals reducing their natural waterproofing and has toxic effects. It also contaminates drinking water supplies and water used for irrigation, stock watering and many industrial purposes and gives rise to problems in recreational waters. These effects cannot be monetised, but are clearly severely detrimental to environmental ecosystems.

OPTIONS

(i) Identify options

6. Three options have been identified to reduce the number of oil pollution incidents from industrial oil storage facilities and compared to the 'business as usual' or 'do nothing' option, as follows:
 - Option 1: do nothing, or 'business as usual' scenario;
 - Option 2: introduce a voluntary scheme;
 - Option 3: use economic incentives such as grants and tax breaks; or
 - Option 4: regulate.

(ii) Issues of equity or fairness

7. The proposed regulations would create a 'level playing field' for oil consumers, ie those who own oil storage facilities in the industrial, commercial and institutional (eg public and voluntary organisations and institutional-residential premises and multi-occupier dwellings) market sectors. They would introduce similar requirements to control oil storage facilities in the agricultural sector implemented under *The Control of Pollution (Silage, Slurry and Agricultural Fuel Oil) Regulations 1991* (amended in 1997). Although waste oil stores would be exempt from the proposed Regulations, it is intended that the same requirements would be introduced in revisions later in 2001 to the waste oil storage provisions of the *Waste Management Licensing Regulations 1994 (as amended)*. The proposed Regulations would thus ensure equity and fairness throughout all sectors of the economy, except for single dwellings in the domestic sector. The cost of meeting the minimum

standards proposed by the regulations would be likely to be proportionally greater for operators of small tanks, such as small businesses and voluntary groups.

8. Householders occupying single dwelling houses in the domestic sector owning heating oil storage tanks (largely found outside conurbations) would not be required to comply with these proposed regulations, as the risk of water pollution from this sector is less than the costs of compliance with our regulatory proposals. However, similar controls for new build domestic heating oil storage tanks for single dwellings are being considered by revisions to Part J of the Building Regulations to be introduced later in 2001. Those existing domestic tanks in single dwellings where there is a risk of pollution of controlled waters can be dealt with by EA's existing anti-pollution powers, though this would be more burdensome for the EA to enforce.
9. The proposed regulations are likely to affect the market for tanks and bunds and may encourage production of less expensive plastic integrally bunded tanks at the smaller end of the market, which would be likely to benefit small businesses and voluntary groups as the costs of installation are lower. If this happens, it would affect some tank manufacturers and firms installing brick or concrete bunds, whose markets may shrink unless they can diversify.

BENEFITS

(i) Identify the benefits

10. The principal benefit of the proposals would be the reduction in the number of oil-related water pollution incidents in England. This would reduce the risk to wildlife and help to safeguard surface waters, groundwaters and drinking water supplies. These measures would help to protect the water environment. Additionally, the reduction of further pollution to land and controlled waters would reduce the costs of remediation of contaminated land in the future.

(ii) Quantifying and valuing the benefits

11. It is difficult to quantify the benefits of the proposed regulations to the sustainability of the water environment. However, the main quantifiable benefits of the 'do something' options (2-4) would stem from reducing the costs of remediating land and waters, ie lower clean-up costs.
 - Option 1 – *do nothing or 'business as usual' scenario*. There are no benefits as industrial sites would be uncontrolled and the risk of pollution would continue at current high levels, except to the extent that businesses take voluntary action.
 - Option 2 – *introduce a voluntary scheme*. This is similar to the Option 1 'business as usual' case. The EA has produced several 'Pollution Prevention Guidelines' concerning the safe handling of oil, including oil storage, and has conducted a moderately successful Oil Care Campaign since January 1995. The EA has worked closely with the oil industry and businesses to educate operators about good environmental practices. As a result, the number of oil-related water pollution incidents has fallen from previous levels, but has stabilised at a high level (30% of all water pollution incidents in 1998). We do not consider that a voluntary scheme, such as a code of practice, is likely to achieve much more than the existing guidance and the clean-up costs would remain similar to those at Option 1."

- Option 3 – *to use economic incentives such as grants and tax breaks.* This option runs against the ‘polluter pays’ principle as the environmental costs are subsidised. The availability of grants would almost certainly encourage tank operators to improve oil storage to reasonable standards. However, there would be no guarantee that grants would lead to an improvement in all tanks. A grant of less than 100% of the marginal costs (ie the extra costs of buying a bunded tank) would still leave tank operators facing extra expenditure and it is likely that a number of them would choose not to comply. Furthermore, it is estimated that there may be around 36,000 new oil storage tanks sold annually in the industrial, commercial and institutional sectors. Providing grants to finance the extra costs for this number of tanks would be far too costly for the public finances.

Zero-rated VAT for new equipment complying with the proposals might reduce the costs for operators who install them, but they would still face additional expenditure. Given the number of tanks involved, such a scheme would be too costly and would not achieve the relatively fast reduction in oil pollution incidents that we are looking for or the ‘level playing field’ between operators.

- Option 4 – *to regulate.* We consider that this option would be the best way of controlling the number of oil-related water pollution incidents and ensuring equity and fairness between operators, as far as possible. In consultation with environmental clean-up companies, the EA and the Institute of Petroleum, we have estimated a range of benefits based on actual incidents occurring in all sectors and for different tank capacities of about £400-£254,000. The average range of benefits (at 1999 prices) are estimated to be around £11,000-£239,000 per incident in avoided clean-up costs, reimbursement to the EA and replacing lost fuel. For a **typical business** with tank sizes of 2,500-5,000 litres the **benefits would be £11,000 – £30,000 per incident.** In addition, polluters may face prosecution and fines of up to £20,000 per incident.

For businesses overall, we estimate that there are **total quantifiable recurring benefits of some £15m-56 million per annum** for new tanks (at 1999 prices). If we also regulate existing tanks as proposed (those at significant risk within 2 years and the remainder within 4 years), we expect the **total benefits of the proposals at 1999 prices would be £250million** by the target year of 2005. These one-off benefits would be in addition to the recurring benefits of regulating new tanks.

COMPLIANCE COSTS FOR BUSINESS, CHARITIES AND VOLUNTARY ORGANISATIONS

(i) Business sectors affected

12. The proposed regulations would have an impact on the following sectors:

- Consumers: Oil consumers, ie operators of oil storage facilities in England in the industrial, commercial, institutional sectors, would be responsible for meeting the requirements of the proposed regulations. A large number of consumers would be affected. In 1998, there were estimated to be 818,423 existing above ground oil storage tanks (of which 99,960 were in the industrial, 468,563 in the commercial and 249,900 in the institutional sectors) in the non-domestic consumer market. An estimated 36,378 new above ground tanks are purchased annually (of which, 5,831 are in the industrial, 18,222 in the commercial and 12,325 in the institutional sectors) most of which are likely to replace existing tanks (which are assumed to be replaced every 25 years).

- Suppliers: Tank manufacturers, oil distributors/deliverers, and firms fitting, installing and maintaining tanks and bunds would be affected indirectly. Suppliers would need to meet the increased demand for tanks, pipework and bunds to the standard required in the regulations within the timescale for compliance. Thereafter, annual sales could be expected to stabilise at a lower level. There are only a few suppliers of oil equipment in the UK. Suppliers have been consulted about any cost-benefit information in the small business 'litmus test'.

(ii) **Compliance costs for a 'typical' business**

13. The costs of Options 1-3 would be minimal for business. In consultation with the EA and OFTEC the oil trade association, we have carried out a cost-benefit study of the costs of the regulations (Option 4) in England for the types of business or organisations most likely to be affected, ie oil consumers in the industrial, commercial and institutional sectors. The study estimates the one-off costs of installing new integrally bunded tanks, which are likely to be cheaper than buying an unbunded tank and building a separate brick bund; and the one-off costs of upgrading existing tanks within 2 years for those at 'significant risk' and within 4 years for the remainder. The costs will vary according to the total oil storage capacity at each premise. For convenience, we have estimated the cost of purchasing or upgrading an individual tank at different tank capacities and consider that small businesses and those with small oil storage facilities should anticipate costs at the lower end of the range.

NON-RECURRING COSTS:

14. The main compliance costs to firms is the one-off cost of upgrading an existing tank or installing a new tank to the required design specification, and in particular providing a bund. The costs will vary depending on tank capacity, which can be 1,000 litres at the lower end and 150,000 litres at the upper end. Most tanks affected by the proposed regulations will have a capacity of about 2,500-5,000 litres and we consider that these will be typical businesses. Small businesses are likely to have a tank capacity in the range of 1,000-2,500 litres.

Costs of installing new bunded tanks

15. It is assumed that new integrally bunded above ground tanks are purchased. There are no additional labour costs beyond the cost that would have been incurred under the 'business as usual' scenario. There may be marginal additional costs for pipework and mobile tank requirements, but we have been unable to cost these. We estimate that the **typical business is likely to face additional costs for installing new bunded tanks of £265 – £487, and small businesses are likely to face additional costs of £211 – £265.** The full range of costs for different tank capacities is below:

Tank capacity (litres)	1,000	1,500	2,500	5,000	30,000	50,000	150,000
Extra cost of bund	£211	£263	£265	£487	£1898	£2960	£12,647

(1999 prices)

Costs of upgrading existing tanks

16. The additional costs of upgrading existing above ground tanks will vary enormously depending on the amount of work that is needed to bring the facilities up to the standard in the proposals and the age of unbunded tanks. Tanks may require remedial work or have to be completely replaced with a new integrally bunded tank.

17. **The typical business is likely to face additional costs in year 4 for upgrading existing tanks of minimal – £845, and small businesses are likely to face additional costs of minimal – £449.** The full range of costs for different tank capacities is given below, assuming a 'worst case' scenario.

Tank capacity (litres)	1,000	1,500	2,500	5,000	30,000	50,000	150,000
Cost for tank where bund requires some remedial work	£200	£200	£200	£200	£200	£200	£200
Marginal cost for tank requiring complete replacement*, including £200 installation cost	£380	£449	£530	£845	£3,037	£4,637	316,230
*Note: This cost is dependent on the age of the tank after 4 years when the proposed regulations come into force. It provides an example of the most expensive scenario, a 4 year old tank which -assuming an average lifespan of 25 years – would have had another 21 years of use.							

(1999 prices)

RECURRING COSTS:

18. The main recurring cost is likely to be routine maintenance to ensure the reasonable standards proposed in the regulations are met at all times, through an annual inspection and service. Maintenance proposals would not be onerous as storage tanks have few mechanical features and brick or concrete bund construction is very durable. Plastic integrally banded tanks have minimal maintenance requirements. These costs have not been included as routine maintenance could be incurred whether or not the proposals are introduced.
19. There are likely to be recurring costs for the minority of businesses in the supplier market. For many firms this is likely to be increased demand for products to meet the timing proposals in the regulations, followed by some reduction in sales and thus lower profits in the interim years until new tanks are purchased. However, the cyclical nature of the loss of profits may be offset to some extent by the number of existing tanks which currently meet the proposals in the regulations and the timing of any maintenance required. We have not been able to quantify these costs.

(iii) Total compliance costs

20. We estimate that the total recurring and non-recurring compliance costs for the oil consumers affected by the proposed regulations in the industrial, commercial and institutional sectors would be as set out in paragraphs 21-23.
21. The number of new tanks purchased per annum in all sectors is 36,378 (based on 1998 figures provided by OFTEC). The EA estimate that some 60-90% of new tanks purchased in the absence of regulations would have been banded anyway and would comply with our proposals. Therefore, the extra cost of the proposed regulations (mainly the bund) would be for those 10-40% of tanks which otherwise would have been bought unbanded. Taking this into account, the total recurring compliance costs for new tanks in all sectors in England is estimated to be **£1.6 – £5.5 million** (at 1999 prices).
22. Based on 1998 OFTEC data, it is estimated that there are 818,423 existing tanks. The EA estimates that 60% of these are banded and, of these, 33% have an inadequate bund. If we take a 'worst case' scenario, where we assume that 60% of existing stock is unbanded or inadequately banded, and the additional cost of the proposals would require complete

replacement of the bund. The total **non-recurring** costs (at 1999 prices) for **existing** tanks in all sectors in England to comply with the proposals (within 2 years for tanks at significant risk and 4 years for the remaining tanks) is estimated to be **£114-£116 million over 4 years (by 2005)** (at 1999 prices).

23. We estimate that the combined total compliance costs of our proposals at paragraph 22 can be **broken down** (discounted to 1999 prices) as follows:

All sectors and tank sizes	Expected total costs
Additional recurring costs of purchasing <u>new</u> tanks	£1.6m – £5.5m per annum
Additional non-recurring costs of upgrading existing tanks at 'significant risk' within 2 years	£14-15million
Additional non-recurring costs of upgrading remaining existing tanks within 4 years	£100-101million

CONSULTATION WITH SMALL BUSINESS: THE 'LITMUS TEST'

24. We have consulted selected small businesses in the consumer (industrial, commercial and institutional premises) and supplier sectors prior to the consultation period by carrying out a litmus test, which assessed the impact of the proposals in the regulations on small businesses. Although for most businesses there were some additional costs, the test showed it was not likely to affect their competitiveness or profitability. Overall the test found that there would be no significant impact to business and that the costs were in line with those used in the regulatory impact assessment.

IDENTIFY ANY OTHER COSTS

25. We have estimated the costs to the environment of options 1 and 2. These figures become the benefits to the environment of regulating (option 4) by avoidance of clean-up costs.
26. It is possible that the oil consumer sector would pass on the costs of compliance with the proposed regulations to citizens by increasing the prices of goods and services. However, many may simply absorb the additional costs and overall we estimate that the impact on inflation would be minimal.
27. There would also be costs to Government. As regulator and enforcer, the EA would monitor and enforce the proposed regulations at an estimated cost of £70,000 in 2001/02. There would probably be further enforcement costs for the proposals in two and four years after the introduction of regulations, but these are unquantified at this stage. Costs would be at a minimal maintenance level thereafter to ensure that the maintenance proposals were met. These costs are significantly lower than the cost of using existing powers at individual sites and the costs to the EA of cleaning up a pollution incident. The proposed regulations would therefore significantly reduce the burden on the EA of oil-related water pollution incidents.
28. Local authorities do not bear any enforcement costs, though local authorities storing oil would need to meet the requirements of these proposals.

RESULTS OF CONSULTATIONS

29. The proposals and the regulatory impact assessment have been discussed extensively with the oil industry. In December 1996, a preliminary formal three month consultation, including a draft compliance cost assessment, was issued to 284 organisations covering industry, regulatory and environmental interests. The consultation period was extended during 1997 and a total of 937 consultation papers were distributed. Responses were received from 108 organisations and the regulations take account of comments made at that time and subsequently in the April 2000 consultation, and of further legislation.

SUMMARY AND RECOMMENDATIONS

30. Non-recurring compliance cost-benefits of Option 4 for a 'typical business' in the oil consumer market are likely to be:

Typical business	Expected costs per tank @ 2,500 – 5,000 litres	Expected benefits per incident for tank @ 2,500 – 5,000 litres
Purchase new facilities	£265-487	£11,000 – £30,000
Upgrade existing facilities	minimal-£845	£11,000 – £30,000

(1999 prices)

31. Recurring costs for maintenance, such as an annual inspection and service, have not been included as they could be incurred whether or not the proposals are introduced. A minority of businesses supplying oil tanks and equipment may incur recurring costs in terms of loss of profits. We have been unable to quantify these.
32. Total compliance cost-benefits of Option 4 for businesses in the oil consumer market and for Government would be recurring for newly purchased tanks, assuming that the level of unbunded or inadequately banded stock remained the same if the proposals were not introduced. We have also estimated that total non-recurring costs of the proposals to regulate existing stock at 'significant risk' within 2 years and remaining existing stock within 4 years. There are no recurring costs of the proposals to regulate existing stock. Estimated total costs (at 1999 prices) are likely to be in the range:

All sectors and tank sizes	Expected total costs	Expected total benefits of reduction in clean-up
<u>Business</u> : additional recurring costs of purchasing <u>new</u> tank, bund	£1.6m – 5.5m per annum	£15m – £56m per annum
<u>Business</u> : additional <u>one-off</u> cost of worst case upgrade of existing tank at 'significant risk' within 2 years and remainder within 4 years	£114 – £116m for existing stock with 2 year and 4 year compliance	£250m for existing stock with 2 year and 4 year compliance
<u>Government</u> : additional <u>one-off</u> costs of monitoring and enforcement	£70,000 in 2001/02, further costs in 2 and 4 years and minimal costs thereafter	Costs avoided of attending pollution incidents, typically £190 – £2,000 per incident

(1999 prices)

33. The historic high incidence of water pollution from inadequate oil storage facilities justifies statutory measures to protect the environment. We recommend that the proposed regulations are brought into force as soon as possible under section 92 of the *Water Resources Act 1991* so that the unquantifiable and the identified quantifiable benefits to the environment can commence.

ENFORCEMENT, SANCTIONS, MONITORING AND REVIEW

34. DEFRA and the EA would jointly issue a publicity leaflet to alert oil consumers of their responsibility for complying with the proposed regulations. This would be issued to consumers with the help of the oil industry trade associations who deliver oil to industrial, commercial and institutional oil storage premises. DEFRA would also issue detailed guidance explaining the proposed regulations.
35. In consultation with DEFRA, the EA would issue guidance and undertake training of regional staff to ensure that the proposed regulations were implemented, monitored and enforced fairly and equitably across England.
36. The proposed regulations provide for operators of oil storage facilities (oil consumers) in breach to be prosecuted and for penalties to be imposed. The EA would be sympathetic to the difficulties facing small businesses and organisations and would encourage them to comply with the proposed regulations so that any sanctions for non-compliance were proportionate to the problem.
37. The EA would monitor compliance with the proposed regulations in the data that is collected for the annual report on pollution incident statistics. The EA would ensure that monitoring data is consistent throughout its regions. If the proposals were introduced, we would formally review the effectiveness of the regulations and consider if the reasonable standards are appropriate in the light of further developments five years after the proposals are introduced.

Contact point:

Jonathan Tweney
 Water Quality Division (WQ4)
 Department for Environment, Food and Rural Affairs
 Floor 3/G15, Ashdown House
 123 Victoria Street
 London SW1E 6DE

Telephone: 020 7944 5348
 Facsimile: 020 7890 5209
 E-mail: Jonathan.Tweney@defra.gsi.gov.uk

ANNEX C

STATUTORY INSTRUMENTS

2001 No. 2954

WATER RESOURCES, ENGLAND

The Control of Pollution (Oil Storage) (England) Regulations 2001

Made - - - - - 21st August 2001

Laid before Parliament 29th August 2001

Coming into force - - - 1st March 2002

The Secretary of State, in exercise of the powers conferred upon her by sections 92 and 219(2) of the Water Resources Act 1991(a), hereby makes the following Regulations:

Citation, commencement, extent and interpretation

1.—(1) These Regulations, which may be cited as the Control of Pollution (Oil Storage) (England) Regulations 2001, shall come into force on 1st March 2002 and extend to England only.

(2) In these Regulations—

“container” means a fixed tank, a drum or a mobile bowser or (even if not connected to fixed pipework) an intermediate bulk container;

“drum” means an oil drum or similar container used for storing oil;

“fixed tank” includes an intermediate bulk container which is connected to fixed pipework;

“oil” means any kind of oil and includes petrol; and

“secondary containment system” means a drip tray, an area surrounded by a bund or any other system for preventing oil which is no longer in its container from escaping from the place where it is stored.

Application of Regulations

2.—(1) Subject to paragraph (2), these Regulations apply to the storage of oil on any premises.

(2) These Regulations do not apply to the storage of oil—

(a) if the oil is waste oil within the meaning of regulation 1(3) of the Waste Management Licensing Regulations 1994(b);

(b) in any container which is situated in a building or wholly underground;

(c) in any container with a storage capacity of 200 litres or less;

(d) on any premises used—

(i) wholly or mainly as a private dwelling if the storage capacity of the container in which it is stored is 3500 litres or less;

(a) 1991 c. 57; there are amendments to sections 92 and 219(2) which are not relevant to these regulations. The relevant powers of the Secretary of State have been devolved in relation to Wales by article 2 of the National Assembly for Wales (Transfer of Functions) Order 1999 (S.I. 1999/672), although there are concurrent powers in relation to those parts of Wales which are within the catchment areas of the rivers, Dee, Wye and Severn (see the entry in Schedule 1 to the Order for the Water Resources Act 1991).

(b) S.I. 1994/1056; to which there are amendments not relevant to these regulations.

[DEFRA 2205]

- (ii) for refining oil; or
- (iii) for the onward distribution of oil to other places; or
- (e) on any farm if the oil is for use in connection with agriculture within the meaning of the Agriculture Act 1947(a).

Requirements for storage of oil—general

3.—(1) Oil shall be stored in a container which is of sufficient strength and structural integrity to ensure that it is unlikely to burst or leak in its ordinary use.

(2) The container must be situated within a secondary containment system which satisfies the following requirements—

- (a) subject to paragraph (5), it must have a capacity of not less than 110% of the container's storage capacity or, if there is more than one container within the system, of not less than 110% of the largest container's storage capacity or 25% of their aggregate storage capacity, whichever is the greater;
- (b) it must be positioned, or other steps must be taken, so as to minimise any risk of damage by impact so far as is reasonably practicable;
- (c) its base and walls must be impermeable to water and oil;
- (d) its base and walls must not be penetrated by any valve, pipe or other opening which is used for draining the system; and
- (e) if any fill pipe, or draw off pipe, penetrates its base or any of its walls, the junction of the pipe with the base or walls must be adequately sealed to prevent oil escaping from the system.

(3) Any valve, filter, sight gauge, vent pipe or other equipment ancillary to the container (other than a fill pipe or draw off pipe or, if the oil has a flashpoint of less than 32°C, a pump) must be situated within the secondary containment system.

(4) Where a fill pipe is not within the secondary containment system, a drip tray must be used to catch any oil spilled when the container is being filled with oil.

(5) Where any drum is used for the storage of oil in conjunction with a drip tray as the secondary containment system, it is sufficient if the tray has a capacity of not less than 25% of—

- (a) the drum's storage capacity; or
- (b) if there is more than one drum used at the same time with the tray, the aggregate storage capacity of the drums.

Fixed tanks

4.—(1) Any fixed tank used for storing oil shall satisfy the following requirements.

(2) Any sight gauge must be properly supported and fitted with a valve which must be closed automatically when not in use.

(3) Any fill pipe, draw off pipe or overflow pipe must be positioned, or other steps must be taken, so as to minimise any risk of damage by impact so far as is reasonably practicable and—

- (a) if above ground, must be properly supported;
- (b) if underground—
 - (i) must have no mechanical joints, except at a place which is accessible for inspection by removing a hatch or cover;
 - (ii) must be adequately protected from physical damage;
 - (iii) must have adequate facilities for detecting any leaks;
 - (iv) if fitted with a leakage detection device which is used continuously to monitor for leaks, the detection device must be maintained in working order and tested at appropriate intervals to ensure that it works properly; and
 - (v) if not fitted with such a device, must be tested for leaks before it is first used and further tests for leaks must be performed, in the case of pipes which have mechanical joints, at least once in every 5 years and, in other cases, at least once in every 10 years; and

(a) 1947 c. 48.

- (c) if made of materials which are liable to corrosion, must be adequately protected against corrosion.
- (4) The tank must be fitted with an automatic overfill prevention device if the filling operation is controlled from a place where it is not reasonably practicable to observe the tank and any vent pipe.
- (5) Any screw fitting or other fixed coupling which is fitted and is in good condition must be used when the tank is being filled with oil.
- (6) Where oil from the tank is delivered through a flexible pipe which is permanently attached to the container—
 - (a) the pipe must be fitted with a tap or valve at the delivery end which closes automatically when not in use;
 - (b) the tap or valve must not be capable of being fixed in the open position unless the pipe is fitted with an automatic shut off device;
 - (c) the pipe must be enclosed in a secure cabinet which is locked shut when not in use and is equipped with a drip tray or the pipe must—
 - (i) have a lockable valve where it leaves the container which is locked shut when not in use; and
 - (ii) be kept within the secondary containment system when not in use.
- (7) Any pump must be—
 - (a) fitted with a non-return valve in its feed line;
 - (b) positioned, or other steps must be taken, so as to minimise any risk of damage by impact so far as is reasonably practicable; and
 - (c) protected from unauthorised use.
- (8) Any permanent vent pipe, tap or valve through which oil can be discharged from the tank to the open must satisfy the following requirements—
 - (a) it must be situated within the secondary containment system;
 - (b) it must be arranged so as to discharge the oil vertically downwards and be contained within the system; and
 - (c) in the case of a tap or valve, it must be fitted with a lock and locked shut when not in use.

Mobile bowzers

- 5.—(1) Any mobile bowser used for storing oil shall satisfy the following requirements.
- (2) Any tap or valve permanently fixed to the unit through which oil can be discharged to the open must be fitted with a lock and locked shut when not in use.
 - (3) Where oil is delivered through a flexible pipe which is permanently attached to the unit—
 - (a) the pipe must be fitted with a manually operated pump or with a valve at the delivery end which closes automatically when not in use;
 - (b) the pump or valve must be provided with a lock and locked shut when not in use;
 - (c) the pipe must be fitted with a lockable valve at the end where it leaves the container and must be locked shut when not in use.

Transitional provisions

- 6.—(1) Subject to paragraphs (2) and (3) below, the preceding provisions of these Regulations shall not apply until 1st September 2005 to the storage of oil in any container if the container was used for that purpose on any premises before 1st September 2001.
- (2) Subject to paragraph (3), if the container or, if there is more than one container within the secondary containment system, any of them is situated less than—
 - (a) 10 metres away from any inland freshwaters or coastal waters; or
 - (b) 50 metres away from a well or borehole.
- the preceding provisions of these Regulations shall apply from 1st September 2003.

(3) If a notice under regulation 7 is not complied with in relation to any container by the date specified in the notice, the preceding provisions of these Regulations shall apply from whichever is the latest of the following—

- (a) the date specified in the notice;
- (b) if the period for compliance is extended under regulation 7(4), the expiry of the extension;
- (c) if there is an appeal against the notice, the date on which the appeal is determined or withdrawn.

Notices to minimise pollution risks in transitional cases

7.—(1) In a case where—

- (a) regulation 6(1) or (2) applies; and
- (b) the Agency considers that there is a significant risk of pollution of controlled waters from the entry of the oil in question into those waters if steps are not immediately taken to minimise that risk,

the Agency may serve notice on the person having custody or control of that oil requiring him to carry out such works, take such precautions or such other steps as, in the opinion of the Agency, are appropriate for minimising that risk having regard to the requirements of regulations 3 to 5.

(2) The notice shall—

- (a) specify or describe the works, precautions or other steps which the person is required to carry out or take;
- (b) state the period within which any such requirement is to be complied with; and
- (c) inform him of his rights under regulation 8.

(3) The period for compliance shall be such period as is reasonable in the circumstances and shall not in any case be less than 28 days.

(4) The Agency may at any time—

- (a) withdraw the notice;
- (b) extend the period for compliance with any requirement of the notice;
- (c) with the consent of the person on whom it is served, modify the requirements of the notice,

and shall do so if so directed by the Secretary of State under regulation 8(4).

Right of appeal in transitional cases

8.—(1) A person served with a notice under regulation 7 may within the period of 28 days beginning with the day on which the notice is served (or within such longer period as the Secretary of State may allow) appeal to the Secretary of State against the notice.

(2) An appeal shall be made by the appellant serving notice on the Secretary of State and the notice shall contain or be accompanied by a statement of the appellant's reasons for appealing and the matters which he wishes the Secretary of State to take into account in determining the appeal.

(3) Before determining an appeal the Secretary of State shall—

- (a) take into account any written representations of the appellant or the Agency; and
- (b) if requested to do so by the appellant or the Agency, afford them the opportunity of appearing before and being heard by a person appointed by the Secretary of State for the purpose.

(4) On determining an appeal the Secretary of State may direct the Agency to withdraw the notice under regulation 7, modify any of its requirements, extend the period for compliance or dismiss the appeal.

(5) The period for compliance with a notice under regulation 7 shall, subject to any direction under paragraph (4) be extended so that it expires on the date on which the Secretary of State determines the appeal or, if the appeal is withdrawn, the date on which it is withdrawn.

Offences

9. A person who has custody or control of any oil in circumstances in which there is a contravention of any provision of regulations 3 to 5 or the requirements of a notice under regulation 7 shall be guilty of an offence and shall be liable—

- (a) on summary conviction to a fine not exceeding the statutory maximum; or
- (b) on conviction on indictment, to a fine.

21st August 2001

Whitty
Parliamentary Under-Secretary of State,
Department for Environment, Food and Rural Affairs

EXPLANATORY NOTE

(This note is not part of the Regulations)

These Regulations require a person having custody or control of oil to carry out certain works and take certain precautions and other steps for preventing pollution of any waters which are controlled waters for the purposes of Part III of the Water Resources Act 1991.

Regulation 2(2) sets out circumstances in which these Regulations do not apply to the storage of oil.

Regulation 3 imposes general requirements in relation to the storage of oil. Additional requirements which apply to specific types of container are imposed by regulation 4 (fixed tanks) and regulation 5 (mobile bowsers).

Regulation 6 contains transitional provisions. Where in a transitional case the Environment Agency considers that there is a significant risk of pollution of controlled waters from the oil in question it has the power to serve a notice on the person having custody or control to minimise the risk (*see regulation 7*). A person served with a notice has a right of appeal to the Secretary of State under regulation 8.

Failure to comply with any of the requirements of regulations 3 to 5 or a notice under regulation 7 is a criminal offence (*see regulation 9*), punishable on conviction on indictment to an unlimited fine or on summary conviction to a fine not exceeding the statutory maximum (currently £5,000).

ANNEX D

If an Oil Spill Occurs

- Observe safety precautions (e.g. no smoking).
- Stop the oil from entering drains or watercourses by containing it with sand or earth.
- Do not spread the oil by hosing it down. Do not add detergents.
- Call the Emergency Hotline (24 hours).

EMERGENCY HOTLINE
0800 80 70 60



Follow the Oil Care Code

- Don't overfill your tank; check the amount of oil already in the tank before receiving a delivery.
- Ensure your oil tank and pipes are properly checked every year by an OFTEC Registered Technician.

System last checked

2000	
2001	
2002	
2003	
2004	
2005	
2006	
2007	
2008	
2009	
2010	



SEPA
scottish environment
protection agency



**ENVIRONMENT
AGENCY**



**GOVERNMENT
AND FIRE SERVICE**

ENVIRONMENTAL ALLIANCE - WORKING TOGETHER