

Geological Disposal

Waste Package Specification for 3 cubic metre drum waste packages

January 2013

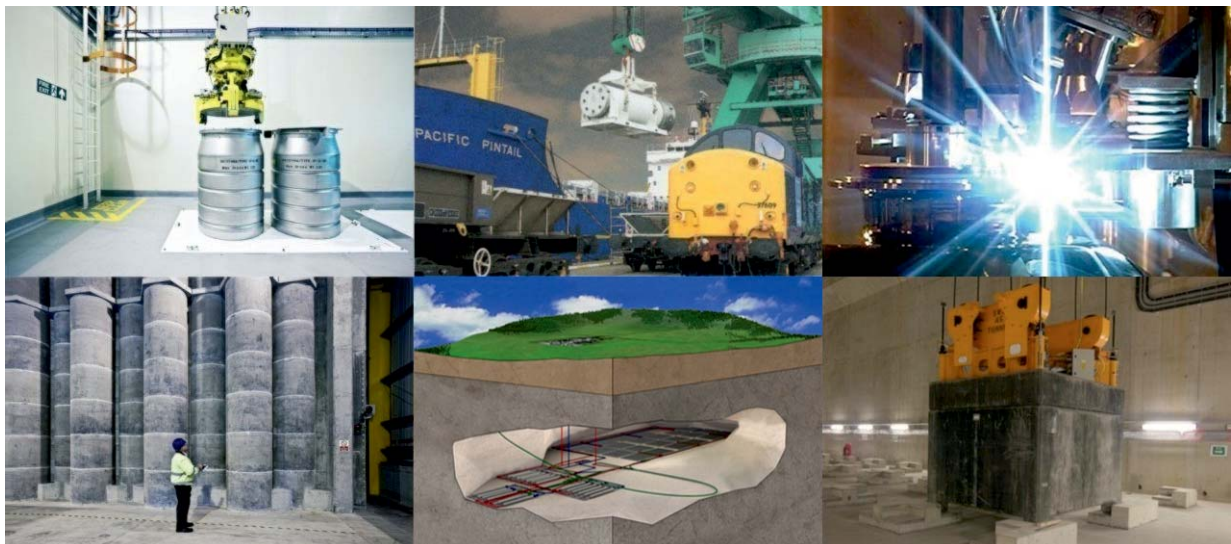

Geological Disposal

Waste Package Specification for 3 cubic metre drum waste packages

January 2013

Conditions of Publication

This report is made available under the NDA Transparency Policy. In line with this policy, the NDA is seeking to make information on its activities readily available, and to enable interested parties to have access to and influence on its future programmes. The report may be freely used for non-commercial purposes. However, all commercial uses, including copying and re-publication, require permission from the NDA. All copyright, database rights and other intellectual property rights reside with the NDA. Applications for permission to use the report commercially should be made to the NDA Information Manager.

Although great care has been taken to ensure the accuracy and completeness of the information contained in this publication, the NDA can not assume any responsibility for consequences that may arise from its use by other parties.

© Nuclear Decommissioning Authority 2013. All rights reserved.

Bibliography

If you would like to see other reports available from NDA, a complete listing can be viewed at our website www.nda.gov.uk, or please write to the Library at the address below.

Feedback

Readers are invited to provide feedback to the NDA on the contents, clarity and presentation of this report and on the means of improving the range of NDA reports published. Feedback should be addressed to:

Head of Communications,
Nuclear Decommissioning Authority (Radioactive Waste Management Directorate),
Curie Avenue,
Harwell Campus,
Didcot,
Oxon,
OX11 0RH, UK

WASTE PACKAGE SPECIFICATION AND GUIDANCE DOCUMENTATION
WASTE PACKAGE SPECIFICATION FOR 3 CUBIC METRE DRUM WASTE PACKAGES

Executive Summary

This document forms part of the *Waste Package Specification and Guidance Documentation* (WPSGD), a suite of documents prepared and issued by the Radioactive Waste Management Directorate (RWMD) of the Nuclear Decommissioning Authority (NDA). The WPSGD are intended to provide a ‘user-level’ interpretation of the RWMD packaging specifications, and other aspects of geological disposal, to assist UK waste producers in the development of plans for the packaging of higher activity waste in a manner suitable for geological disposal.

Key documents in the WPSGD are the *Waste Package Specifications* (WPS) which define the requirements for the transport and geological disposal of waste packages manufactured using standardised designs of waste container. The WPS are based on the high level requirements for all waste packages as defined by the *Generic Waste Package Specification* (GWPS) and are derived from the bounding requirements for waste packages containing a specific category of waste, as defined by the relevant *Generic Specification*.

This document provides a specification for waste packages containing low heat generating waste that are to be manufactured using the 3 cubic metre drum, a standardised design of waste container that has been shown to be suitable for the packaging of such wastes for transport and geological disposal.

The documents that make up the WPSGD will be subject to periodic revision which may lead to significant changes in packaging requirements. Users are therefore advised to contact RWMD, or refer to the NDA Bibliography at www.nda.gov.uk, to confirm that they are in possession of the latest version of any documentation used.

WPSGD DOCUMENT NUMBER WPS/320 - VERSION HISTORY		
VERSION	DATE	COMMENTS
WPS/320/01	July 2005	Aligns with GWPS (Nirex Report N/104) as published June 2005
WPS/320/02	October 2007	Updated to acknowledge NDA assumption of Nirex responsibilities Aligns with Issue 2 of GWPS (Nirex Report N/104) as published March 2007.
WPS/320/03	March 2008	Changes to NII SAPs and modelling of DBAs
WPS/320/04	January 2013	Aligns with Generic Specification for waste packages containing low heat generating waste (NDA/RWMD/068) as published August 2012. Issue for trial use by waste producers.

1 Introduction

RWMD produces packaging specifications as a means of providing a baseline against which the suitability of plans to package higher activity waste for geological disposal can be assessed. In this way we assist the holders of radioactive waste in the development and implementation of such plans, by defining the requirements for waste packages which would be compatible with the anticipated needs for transport to and disposal in a geological disposal facility (GDF).

The packaging specifications form a hierarchy which comprises three levels:

- The *Generic Waste Package Specification* (GWPS) [1]; which defines the requirements for all waste packages which are destined for geological disposal;
- *Generic Specifications*; which apply the high-level packaging requirements defined by the GWPS to waste packages containing a specific type of waste; and
- *Waste Package Specifications* (WPS); which apply the general requirements defined by a Generic Specification to waste packages manufactured using standardised designs of waste container.

As a means of making the full range of RWMD packaging specifications available to waste producers and other stakeholders, a suite of documentation known as the *Waste Package Specification and Guidance Documentation* (WPSGD) is published and maintained for ready access (i.e. via the NDA website at www.nda.gov.uk). The WPSGD includes a range of WPS for different waste package types together with explanatory material and guidance that users will find helpful when it comes to application of the WPS to practical packaging projects. For further information on the extent and the role of the WPSGD, reference should be made to the *Introduction to the RWMD Waste Package Specification and Guidance Documentation* [2].

This WPS applies the requirements for waste packages containing low heat generating waste, which include those classed as intermediate level waste (ILW), as defined by the *Generic Specification for waste packages containing low heat generating waste* [3], to waste packages that are manufactured using the 3 cubic metre drum waste container. It is supported by a number of other documents from the WPSGD, notably *Guidance on the achievement of the Waste Package Specifications for unshielded waste packages* [4].

The suitability of proposals to package specific wastes using the 3 cubic metre drum waste container, such that they would result in the production of disposable waste packages, is assessed by way of the RWMD *Disposability Assessment Process* [5]. At the conclusion of such an assessment a *Letter of Compliance* (LoC) can be issued to indicate that the proposed waste packages would be compliant with this WPS and thereby with the safety cases for the transport of the waste to, and its disposal in a GDF. Waste packagers intending to submit waste packaging proposals for such assessment by RWMD are referred to *Guidance on the preparation of submissions for the disposability assessment of waste packages* [6].

2 The 3 cubic metre drum waste container

The 3 cubic metre drum (Figure 1) is one of a limited range of standardised designs of waste container that have been shown to be suitable for the packaging of low heat generating waste in a manner that is compatible with our plans for the geological disposal of such wastes.

Figure 1 3 cubic metre drum



The 3 cubic metre drum waste container is used to manufacture 'unshielded waste packages' which signifies that it is typically fabricated from relatively thin section stainless steel, which provides little radiation shielding of the waste package radionuclide contents. Because of this, remote techniques are generally utilised for the handling of such waste packages and transport through the public domain will take place inside a protective transport container. The transport packages that result from the combination of a 3 cubic metre drum waste package and a transport container will generally be classed as Type B transport packages under the IAEA *Regulations for the Safe Transport of Radioactive Material* [7].

The 3 cubic drum is generally intended for use in the packaging of a range of liquid, sludge and slurry wastes which are typically conditioned of by a process of 'in-drum mixing' of the waste with an immobilising material. Guidance has been produced on the achievement of the requirements for such wastefoms [8].

3 Packaging criteria for 3 cubic metre drum waste packages

This WPS defines the key features of the 3 cubic metre drum waste container and sets minimum standards of performance for the waste packages that it can be used to manufacture. The requirements defined below are relevant to all stages of the long-term management of the waste package but, in some cases, are applied at particular times during that management.

It is assumed that 3 cubic metre drum waste packages will be transported to a GDF, within a standard waste transport container (SWTC). Three designs of SWTC are currently envisaged, providing nominal shielding thicknesses of 70mm, 150mm and 280mm of steel with a density of 7700kg m⁻³.

It should be noted that, where the words *shall* and *should* are used in defining the requirements that make up this WPS, their use is consistent with the recommendations of BS 7373:1998 [9] and that they have the following meaning:

- '*shall*' denotes a limit which is derived from consideration of a regulatory requirement and/or from a fundamental assumption regarding the current designs of the transport or disposal facility systems;
- '*should*' denotes a target from which relaxations may be possible if they can be shown¹ not to result in any significant reduction in the overall safety of the geological disposal system.

3.1 Requirements for the waste container

3.1.1 General properties

The properties of the waste container, the standard features of which are shown in Figure 2, *shall* be such that, in conjunction with those of the wasteform, it satisfies all of the requirements for the waste package.

Figure 2 Standard features of the 3 cubic metre drum

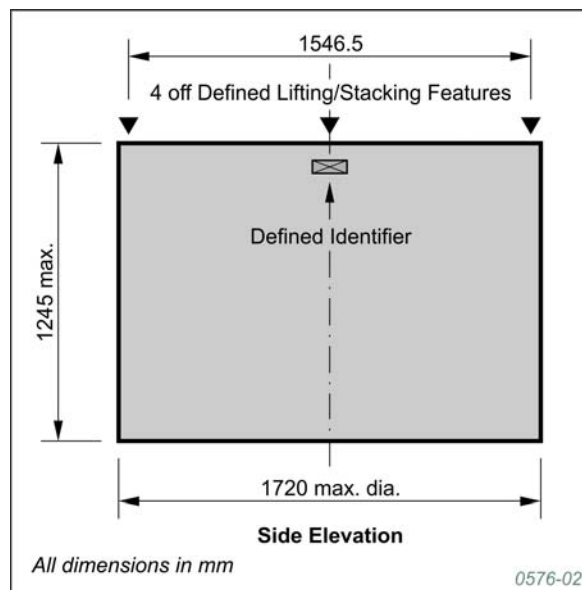

¹ This would generally be by way of the Disposability Assessment Process.

3.1.2 External dimensions

The overall dimensional envelope of the waste package *shall* not exceed:

- Height: 1245mm
- Diameter: 1720mm

3.1.3 Handling feature

The waste container *shall* incorporate four equally spaced lifting points, in the form of twistlock apertures of dimensions and geometry as defined in Figure 3, located in the layouts shown in Figure 4.

The waste package *shall* be capable of being lifted with a force of 160kN using two diametrically opposite twistlock apertures, without exhibiting any permanent deformation

Figure 3 Twistlock geometry and dimensions

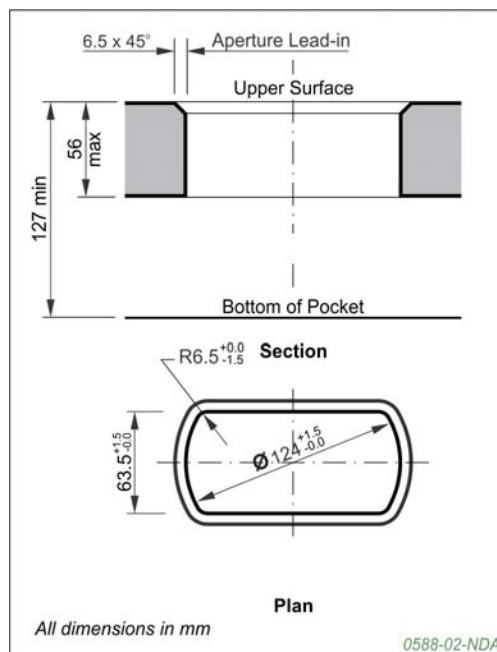
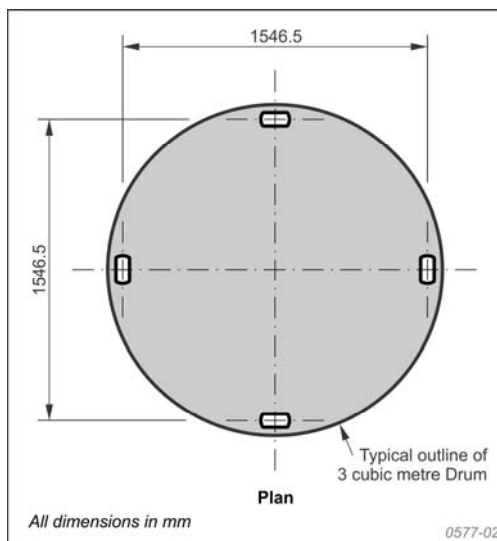

Figure 4 Layout of lifting features of 3 cubic metre drum



3.1.4 Stackability

The waste package *shall* be capable of withstanding a compressive load of 480kN applied along the vertical axis of the waste package. Under these load conditions, the waste package *shall* not exhibit any permanent deformation or abnormality that would render it incompatible with any of the requirements defined in this WPS.

3.1.5 Identification

The waste container *shall* be marked with a unique identifier, comprising ten alpha-numeric characters each with a height of between 6mm and 10mm, and in a form that complies with the relevant RWMD specification [10] (Figure 5).

The identifier *shall* be marked on each vertical surface of the waste container, at the mid-point of each lifting feature, the centre line being located 50mm down from the top edge of the waste container (Figure 2).

The waste package *shall* remain identifiable by automated systems for a minimum period of 150 years following manufacture.

Figure 5 Form of waste package identifier

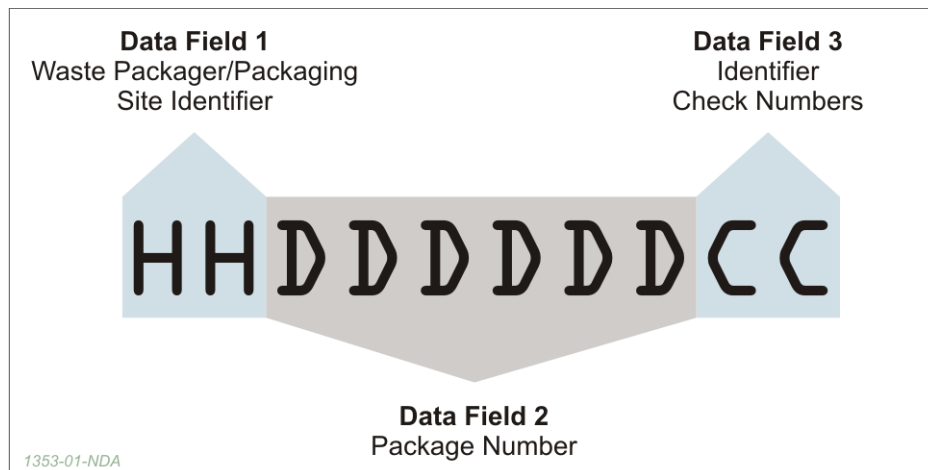

3.1.6 Durability of integrity

The integrity of the waste container (i.e. its safe handling by way of its handling feature, stackability, containment function and the functionality of any engineered vent) *shall* be maintained for a period of 150 years and *should* be maintained for a period of 500 years following manufacture of the waste package.

3.2 Requirements for the wasteform

The physical, chemical, biological and radiological properties of the wasteform *shall*:

- make an adequate contribution to the overall performance of the waste package; and
- have no significant deleterious effect on the performance of the waste container.

The properties of the wasteform *shall* comply with those defined by the *Wasteform specification for waste packages containing low heat generating waste* [11].

Evolution of the wasteform *shall* ensure maintenance of the waste package properties that are necessary for safe transport and operations at a GDF as defined by the GWPS [1].

Evolution of the wasteform *shall* ensure maintenance of the required safety functions for waste package post-closure performance as defined by the GWPS [1] and set out in the *Environmental Safety Case (ESC)* [12].

The required properties of the wasteform *shall be* maintained for a period of 150 years and *should be* maintained for a period of 500 years following manufacture of the waste package.

3.3 Requirements for the waste package

3.3.1 Maximum gross mass

The gross mass of the waste package *should* not exceed 8,000kg and *shall* not exceed 12,000kg.

3.3.2 External dose rate

The external dose rate of the waste package *should* be such that, when it is carried with in a transport container providing 280mm of shielding with a density of 7700kg m⁻³, the dose rate at 1m from any external surface of the transport package, under normal conditions of transport, does not exceed 0.1mSv h⁻¹ and the dose rate at its external surface does not exceed 2mSv h⁻¹.

3.3.3 Heat output

The total heat generated by the waste package *should* not exceed 400W at the time of transport.

The heat generated by the waste package *should* not exceed 15W and *shall* not exceed 250W at the time of disposal vault backfilling

3.3.4 Surface contamination

The non-fixed surface contamination of the waste package *shall* be kept as low as reasonably practicable and, when averaged over an area of 300cm² of any part of the surface of the waste package, *should* not exceed:

- Beta, gamma and low toxicity² alpha emitters: 4.0Bq cm⁻²
- All other alpha emitters: 0.4Bq cm⁻²

² Defined as: uranium-235, uranium-238, thorium-232, thorium-228, thorium-230 and any alpha emitter with a half-life of less than 10 days.

3.3.5 Gas generation

The generation of bulk, radioactive and toxic gases by the waste package *shall* comply with the requirements for safe transport and disposal.

The waste package *should* incorporate a means by which internally generated gases can be vented. The design of the venting mechanism *shall* be such that:

- the release of activity in particulate form from the waste package is minimised;
- excessive pressurisation of the waste package does not occur at any time during a period of 500 years following manufacture; and
- the ingress of groundwater into the waste package in the post-closure period is minimised.

A design pressure constraint *shall* be defined and justified for the internal pressure of an unvented waste package such as to ensure that the requirements stated above are achieved. The design pressure constraint *shall* not be exceeded for a period of 150 years and *should* not be exceeded for a period of 500 years following manufacture of the waste package.

The total gas generated³ and released by the waste package during transport *shall* not exceed 266 litres per day.

The release of gas from the waste package during transport *should* not exceed:

- Hydrogen: 1.4 litres per day
- Methane: 2.0 litres per day

The release of activity in gaseous form from the waste package during transport *should* not exceed 1.5E-03 A₂ per day.

The release of activity in gaseous form from the waste package during the GDF operational period *shall* be limited to ensure compliance with the assumptions made in the ESC [12] for the limitation of off-site radiation dose, and *should* not exceed:

- Hydrogen-3: 20kBq per hour
- Carbon-14: 450Bq per hour
- Radon-222: 370Bq per hour

³ All specified gas generation rates are for volumes of gas at standard temperature and pressure (i.e. 0°C and 101kPa).

3.3.6 Criticality safety

The presence of fissile material⁴, neutron moderators and reflectors in the waste package *shall* be controlled to ensure that:

- criticality during transport is prevented;
- the risk of criticality during the GDF operational period is tolerable and as low as reasonably practicable; and
- in the GDF post-closure period both the likelihood and the consequences of a criticality are low.

The total quantity of fissile material in the waste package *should* not exceed 47g⁵.

The quantities of fissile material, neutron moderators and reflectors in the waste package *shall* be controlled to ensure that, when it forms part of a transport package, it can satisfy the criticality safety requirements of the IAEA Transport Regulations.

A safe fissile mass (SFM) *shall* be defined and justified for the total quantity of fissile material in the waste package such as to ensure that the requirements stated above are achieved. Procedures *shall* be established to ensure that the SFM is not exceeded during waste package manufacture.

3.3.7 Accident performance

Under all credible accident scenarios the release of radionuclides and other hazardous materials from the waste package *shall* be low and predictable.

The waste package *should* exhibit progressive release behaviour within the range of all credible accident scenarios.

The impact and fire accident performance of the waste package *shall* be such as to ensure that, when it forms part of a transport package, it can satisfy the requirements of the IAEA Transport Regulations for Type B transport packages under accident conditions of transport.

The accident performance of the waste package *shall* ensure that, in the event of any credible accident during the GDF operational period, the on- and off-site doses resulting from the release of radionuclides from the waste package *shall* be as low as reasonably practicable and *should* be consistent with meeting the relevant Basic Safety Levels.

⁴ Defined as uranium-233, uranium-235, plutonium-239 and plutonium-241.

⁵ This limit being the mass of plutonium-239, or the total mass of all fissile nuclides which would produce the equivalent reactivity of 47g of plutonium-239 with optimal shape and neutron moderation and reflection.

3.4 Requirements for the manufacture and storage of waste packages

Adequate controls *shall* be established and applied to ensure that manufactured waste packages have the properties and performance required of them.

Adequate controls *shall* be applied during any period of interim storage to ensure that waste packages retain their required properties and performance.

3.4.1 Quality management

Adequate management arrangements *shall* be applied to all aspects of the packaging of radioactive wastes, and the storage of waste packages, that affect product quality.

These arrangements, which *shall* comply with the relevant RWMD specification [13], *shall* be agreed with RWMD prior to the start of the activities to which they relate.

3.4.2 Waste package data and information recording

Information *shall* be recorded for each waste package covering all relevant details of its manufacture and interim storage. This information *shall* be sufficient to enable assessment of the characteristics and performance of the waste package against the requirements of all stages of long-term management.

Information *shall* be recorded regarding the quantity of those radionuclides of relevance to the disposability of the waste package [14].

The arrangements for data and information recording *shall* comply with the relevant RWMD specification [15] and *shall* be agreed with RWMD prior to the start of the activities to which they relate.

3.4.3 Controls on waste packages containing nuclear materials

The safeguards status of any nuclear material⁶ contained within the waste package *shall* be ascertained and recorded.

The quantity of nuclear material contained within a waste package *should* be such that the transport package will require physical protection no higher than that defined by the Office for Nuclear Regulations as Category II.

⁶ i.e. all isotopes of uranium, plutonium and/or thorium.

References

- 1 NDA, *Geological Disposal: Generic Waste Package Specification*, NDA Report No. NDA/RWMD/067, 2012.
- 2 NDA, *Geological Disposal: Introduction to the RWMD Waste Package Specification and Guidance Documentation*, WPS/100/04, 2013.
- 3 NDA, *Geological Disposal: Generic specification for waste packages containing low heat generating waste*, NDA Report No. NDA/RWMD/068, 2012.
- 4 NDA, *Geological Disposal: Guidance on the achievement of the Waste Package Specifications for unshielded waste packages*, WPS/701/01, 2013.
- 5 NDA, *Geological Disposal: Radioactive wastes and assessment of the disposability of waste packages*, NDA Report No. NDA/RWMD/039, 2010.
- 6 NDA, *Geological Disposal: Guidance on the preparation of submissions for the disposability assessment of waste packages*, WPS/908/03, 2013.
- 7 IAEA, *Regulations for the Safe Transport of Radioactive Material 2009 Edition*, IAEA Safety Standards Series No. TS-R-1, 2009.
- 8 NDA, *Geological Disposal: Guidance on the achievement of the required properties of encapsulated wasteforms* WPS/502/01, 2013.
- 9 British Standards Institution, *Guide to the Preparation of Specifications*, BS7373, 1998.
- 10 NDA, *Geological Disposal: Specification of waste package identification system*, WPS/410/02, 2008.
- 11 NDA, *Geological Disposal: Wasteform specification for waste packages containing low heat generating waste*, WPS/501/01, 2013.
- 12 NDA, *Geological Disposal: Generic Environmental Safety Case main report*, NDA Report No. NDA/RWMD/021, 2010.
- 13 NDA, *Geological Disposal: Waste package quality management specification*, WPS/200/02, 2008.
- 14 Nirex, *The Identification of Radionuclides Relevant to Long-term Waste Management in the UK*, Nirex Report No. N/105, 2004.
- 15 NDA, *Geological Disposal: Specification for waste package data and information recording requirements*, WPS/400/02, 2008.



001

Certificate No 4002929



001

Certificate No 4002929

Nuclear Decommissioning Authority
Radioactive Waste Management Directorate
Building 587
Curie Avenue
Harwell Oxford
Didcot
Oxfordshire OX11 0RH

t +44 (0)1925 802820

f +44 (0)1925 802932

w www.nda.gov.uk

© Nuclear Decommissioning Authority 2013