

(12) **UK Patent**

(19) **GB**

(11) **2465293**

(13) **B**

(45) Date of Publication:

11.08.2010

(54) Title of the invention: **Printing material container, and board mounted on printing material container**

(51) INT CL: **B41J 2/175** (2006.01)

(21) Application No: **0922617.6**

(22) Date of Filing: **22.12.2006**

Date Lodged: **23.12.2009**

(30) Priority Data:

(31) **2005372028** (32) **26.12.2005** (33) **JP**

(31) **2006220751** (32) **11.08.2006** (33) **JP**

(62) Divided from Application No
0819698.2 under Section 15(9) of the Patents Act 1977

(43) Date A Publication: **19.05.2010**

(72) Inventor(s):

Noboru Asauchi

(73) Proprietor(s):

Seiko Epson Corporation
(Incorporated in Japan)
4-1 Nishishinjuku 2-chome, Shinjuku-ku,
Tokyo 163-0811, Japan

(74) Agent and/or Address for Service:

Miller Sturt Kenyon
9 John Street, LONDON, WC1N 2ES,
United Kingdom

(56) Documents Cited:

GB 2446311 A **GB 2424623 A**
GB 2369801 A **EP 1598198 A2**
EP 1188567 A2

(58) Field of Search:

As for published application 2465293 A viz:

INT CL **B41J, H05K**

Other: **EPODOC WPI**

updated as appropriate

Fig.1

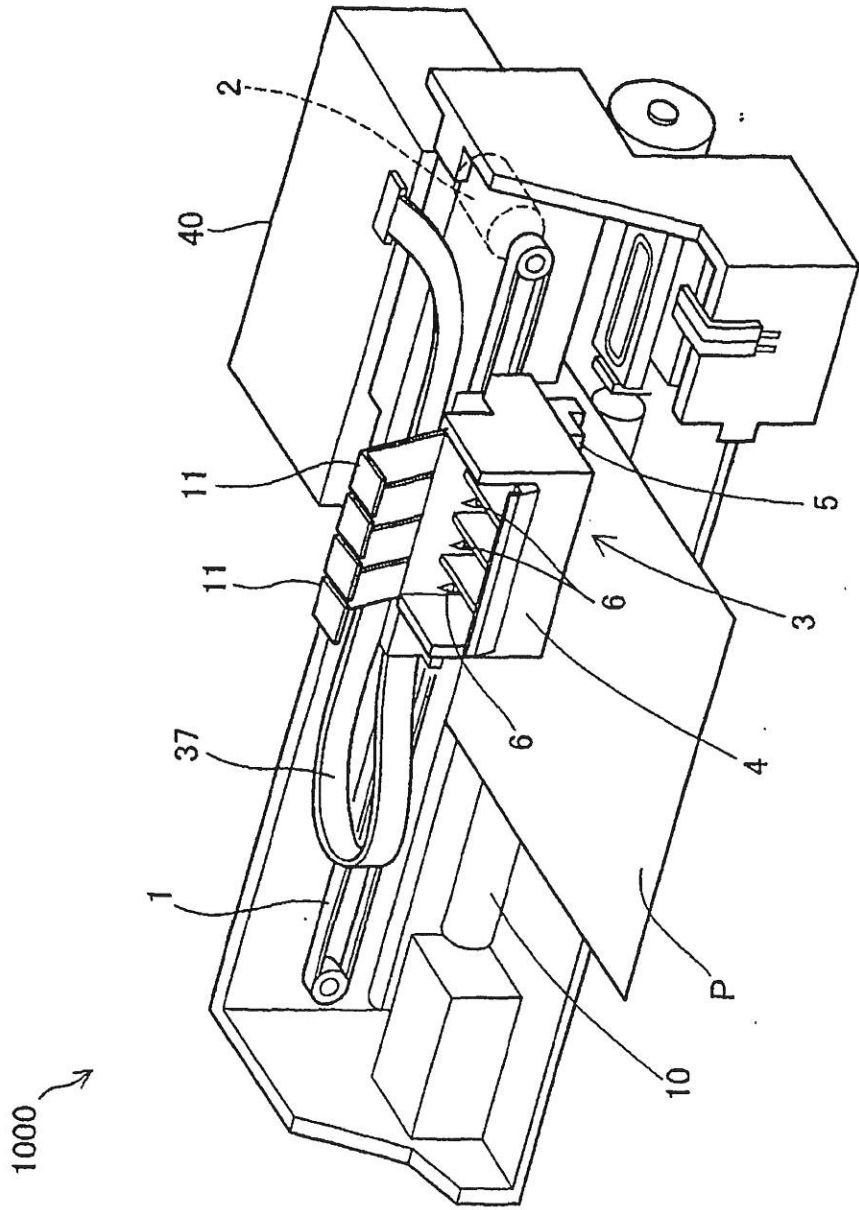

Fig.2

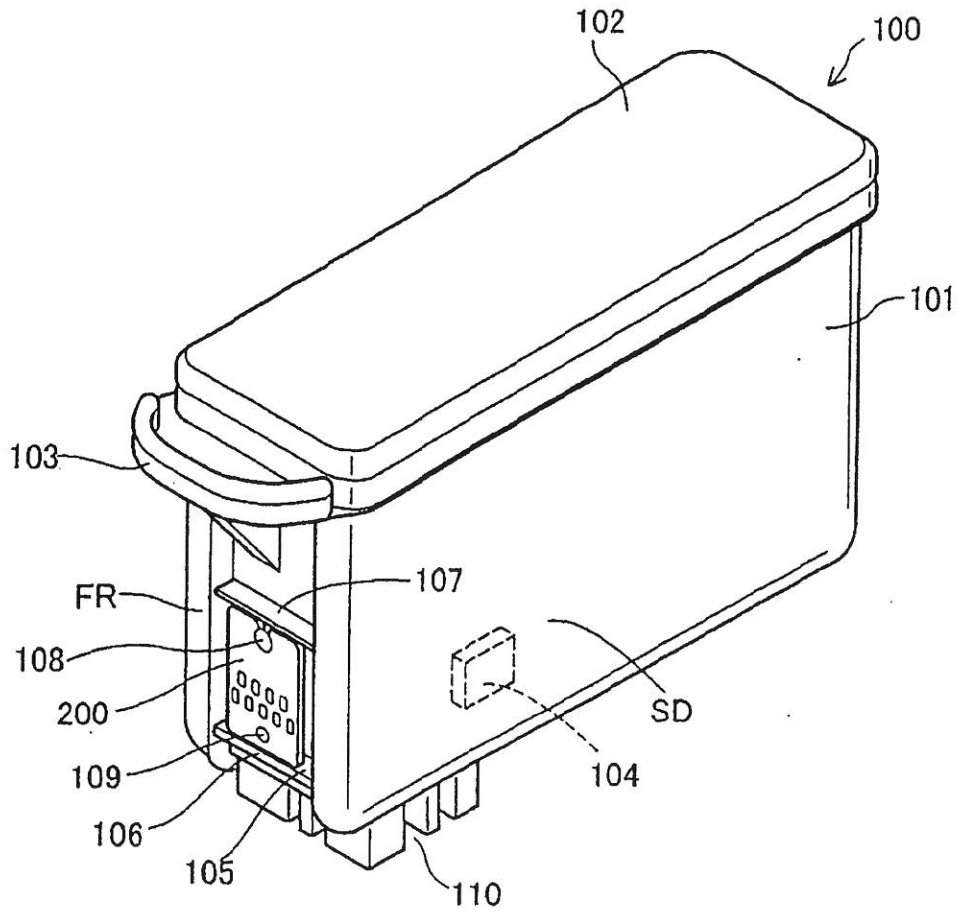

Fig.3A

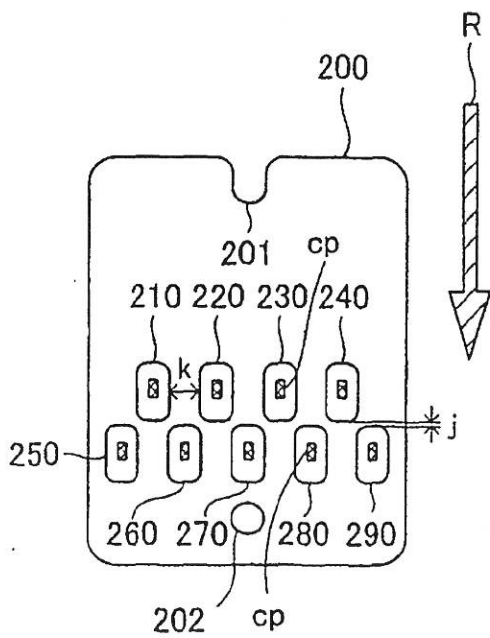

Fig.3B

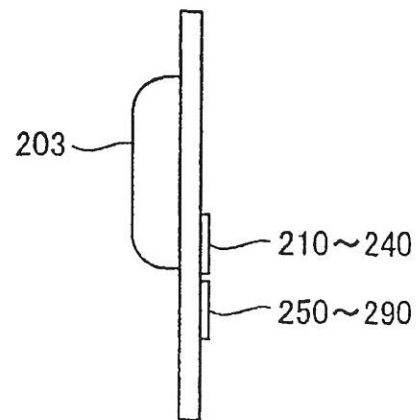
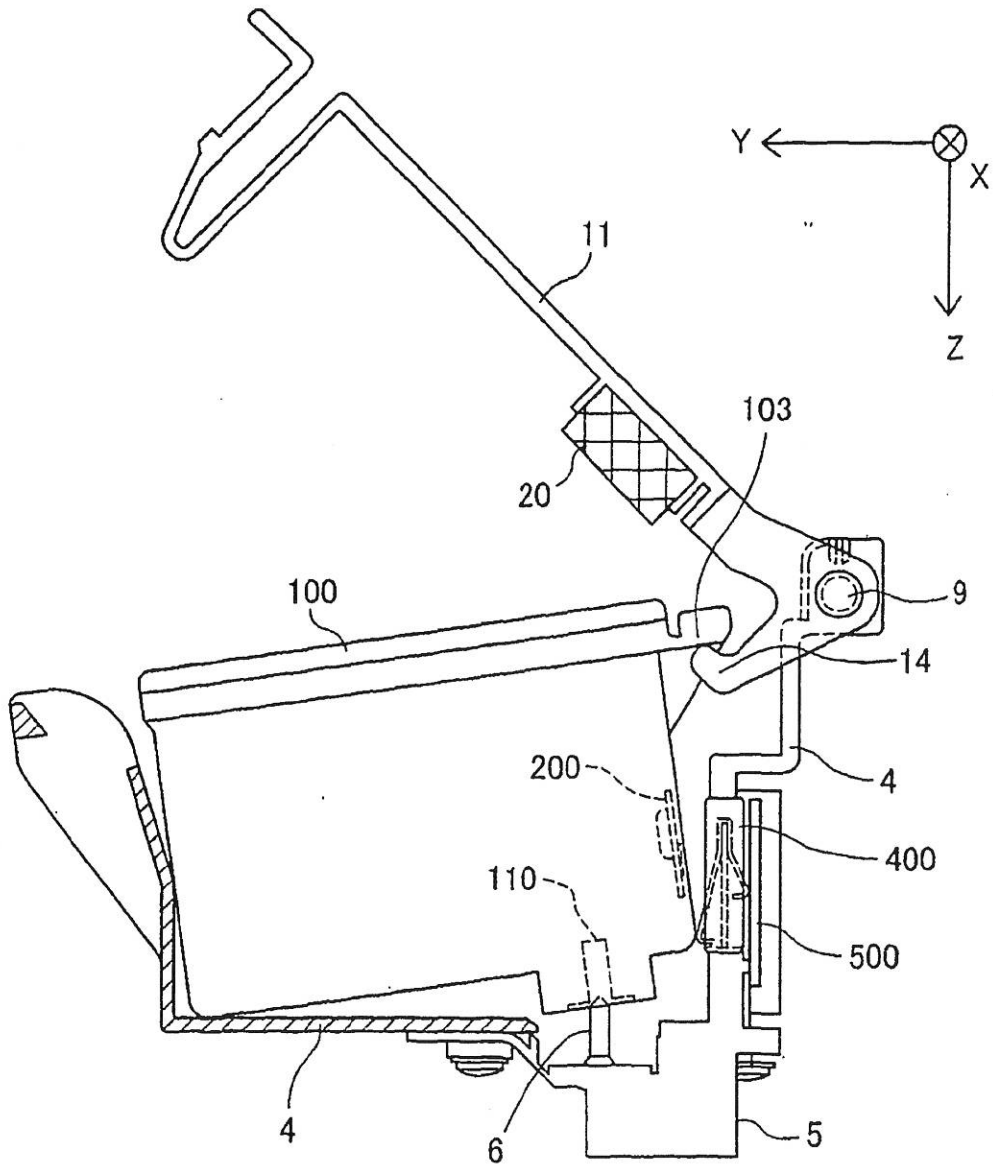

Fig.4



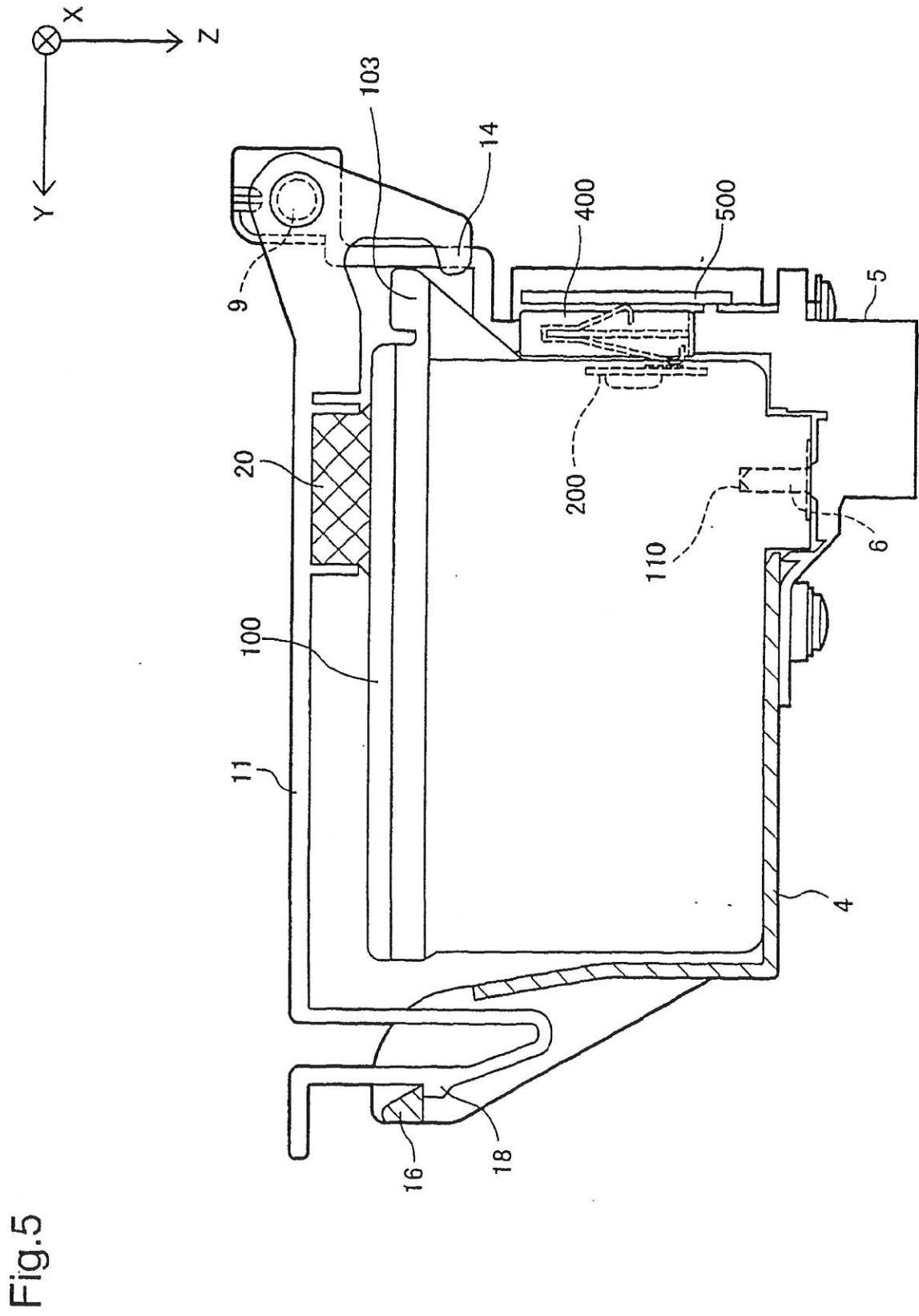

Fig.6A

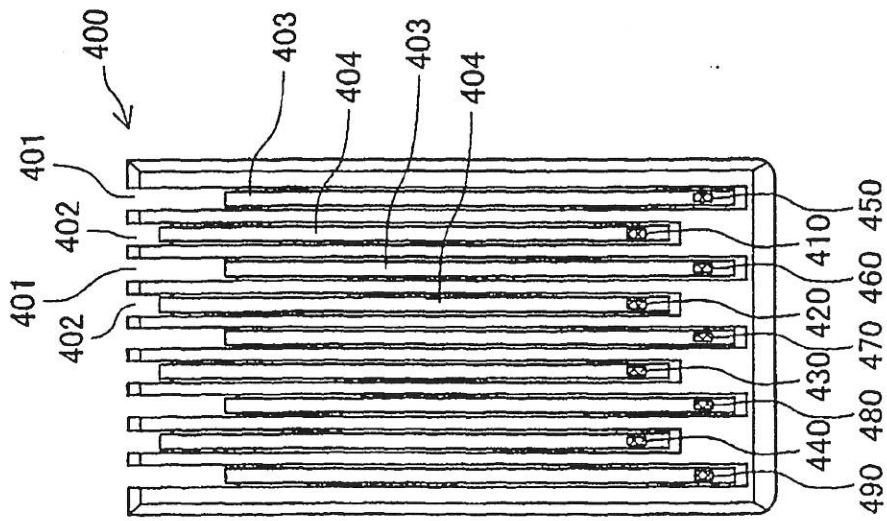

Fig.6B

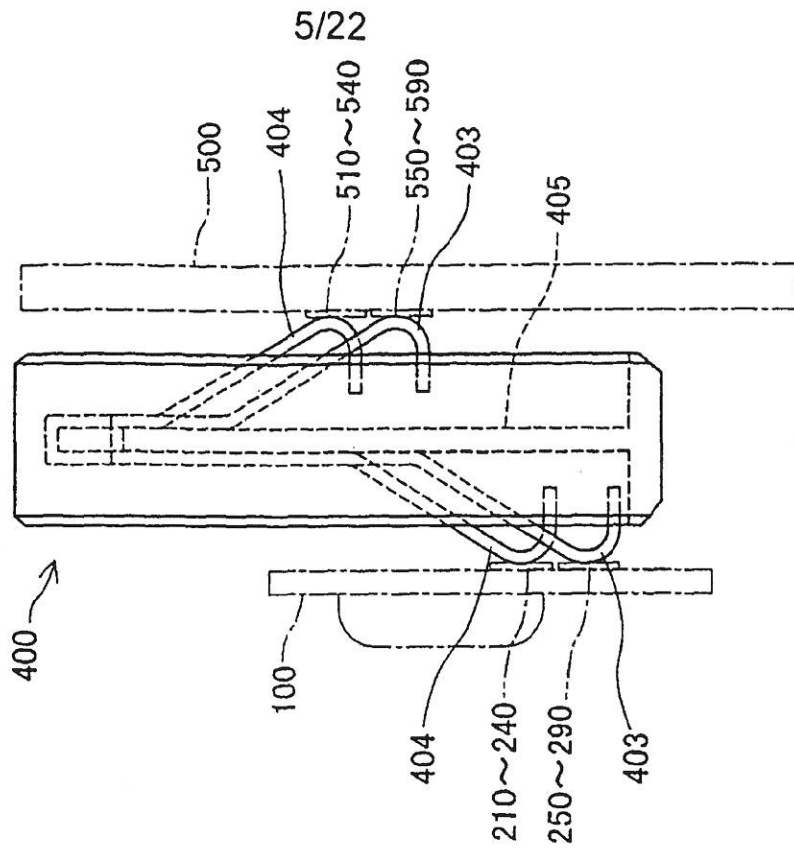

Fig.7

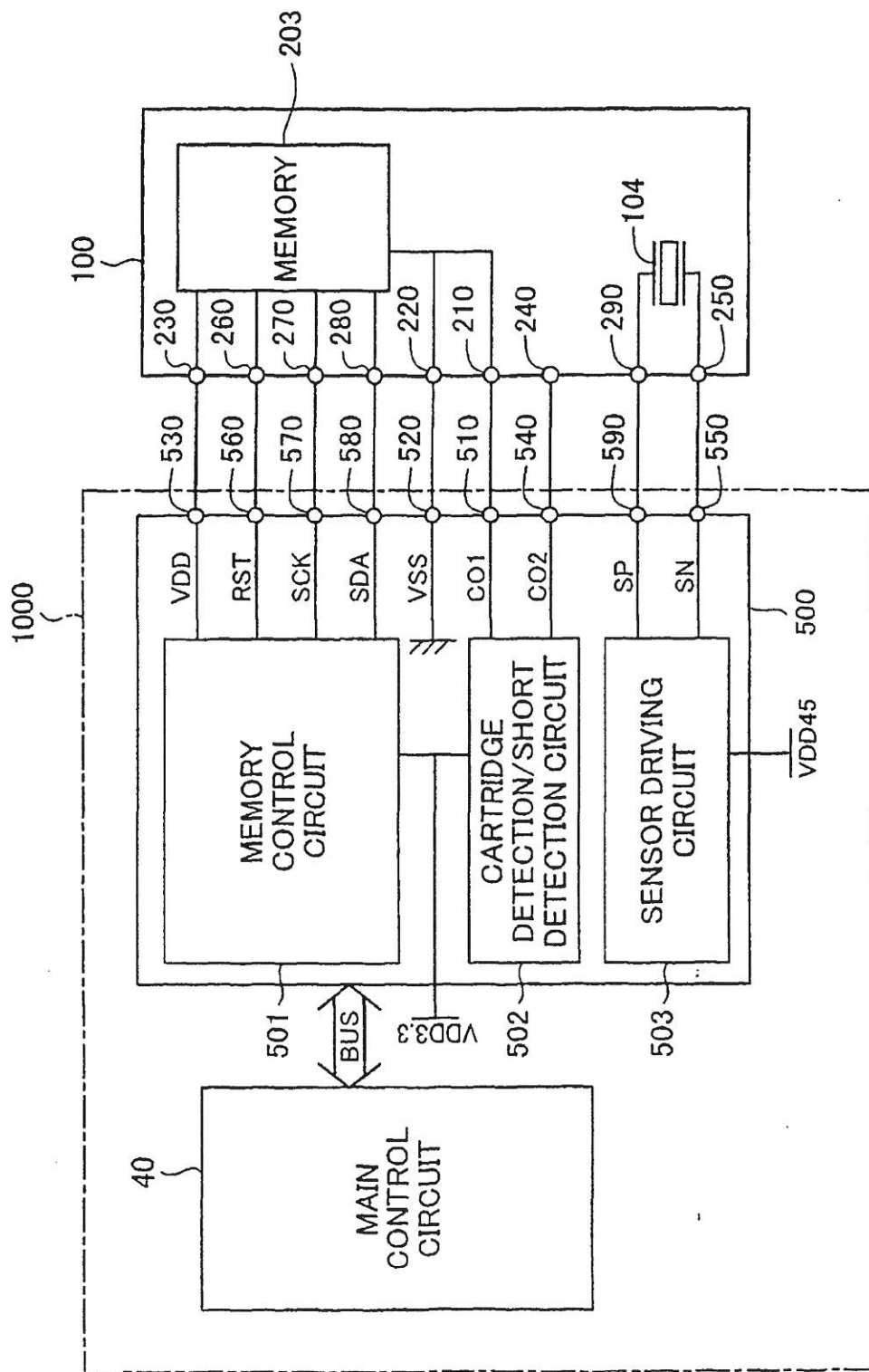

Fig.8

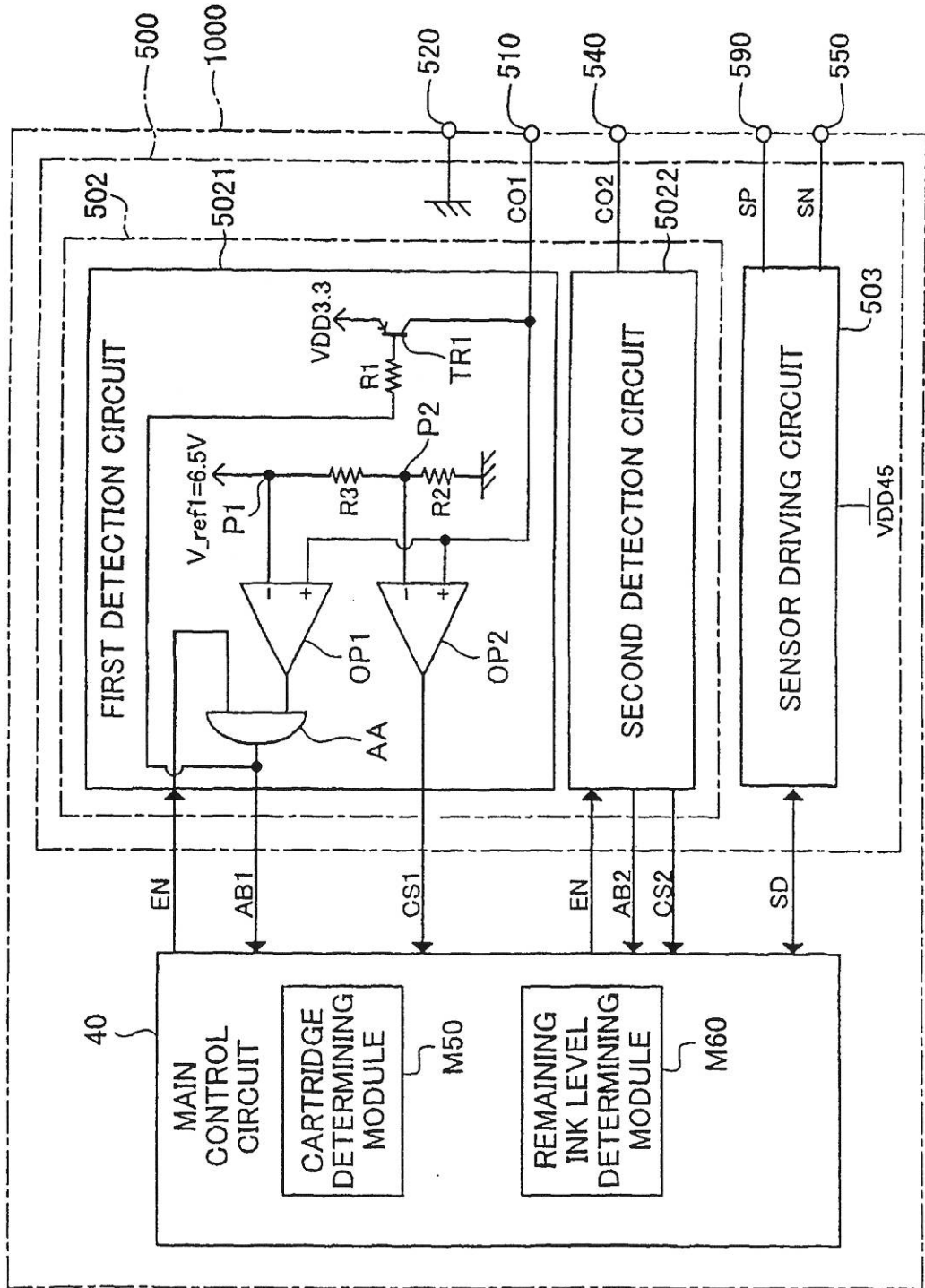

Fig.9

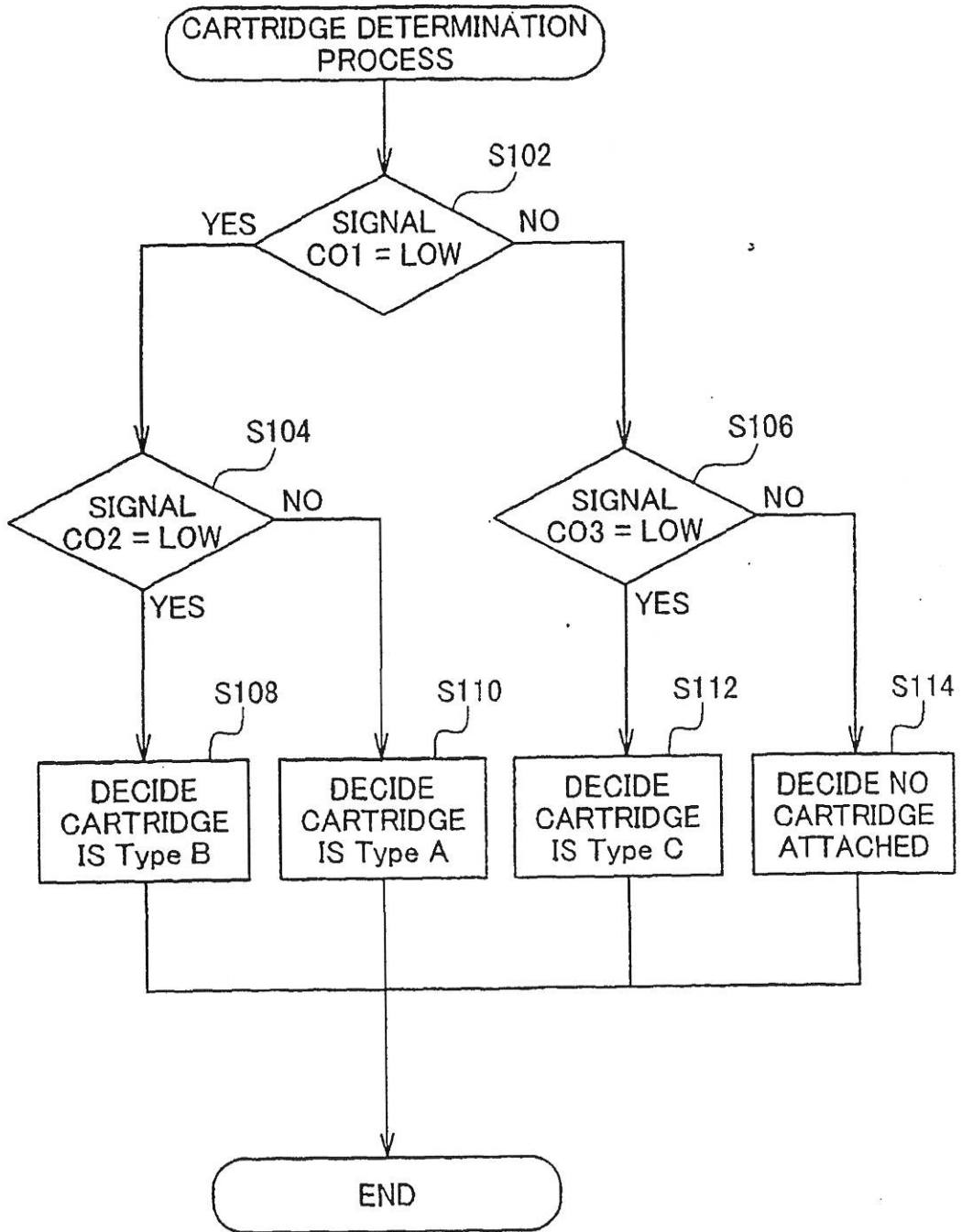
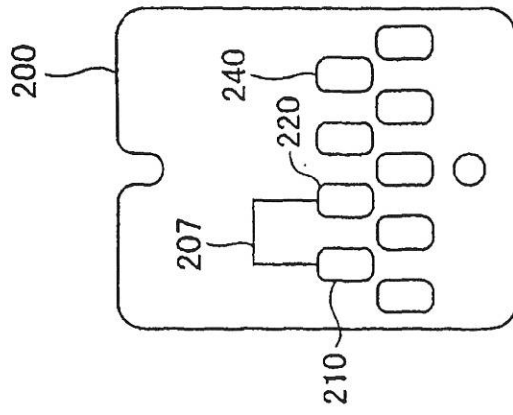
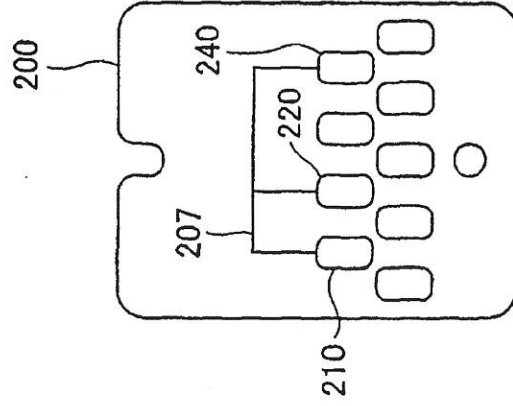

Fig.10A



typeA

Fig.10B



typeB

Fig.10C

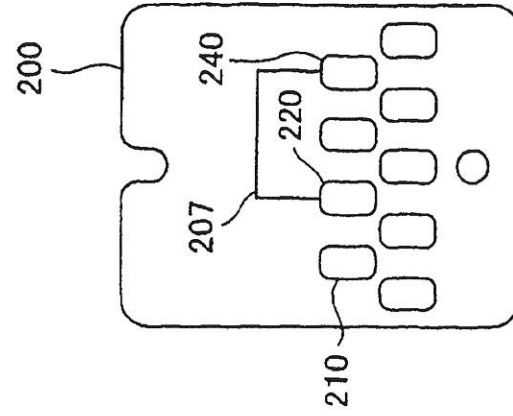

typeC

Fig.11

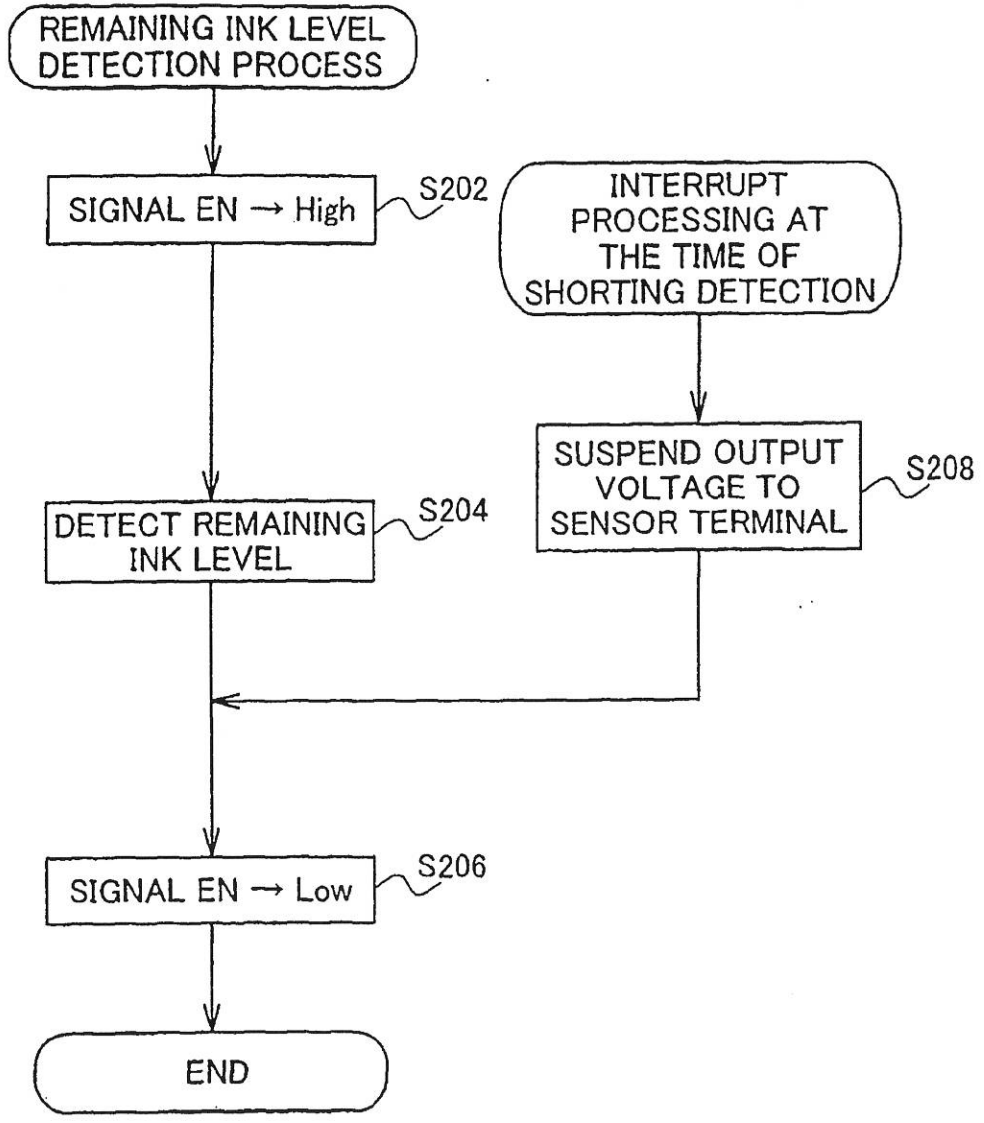

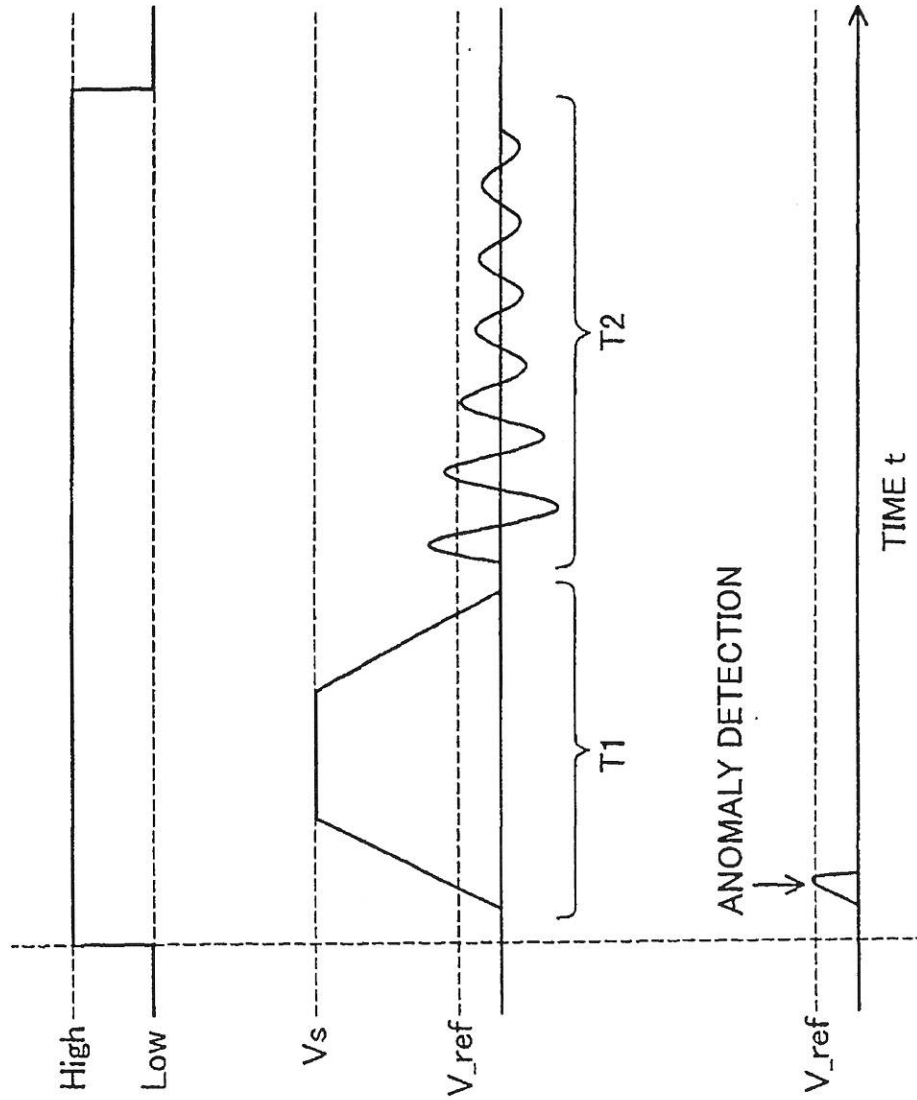

Fig.12A

Fig.12B SENSOR VOLTAGE (NORMAL)

Fig.12C SENSOR VOLTAGE (SHORTING)

Fig.13

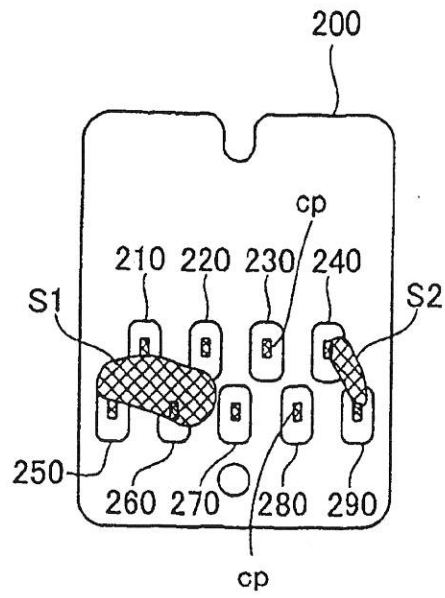

Fig.14A

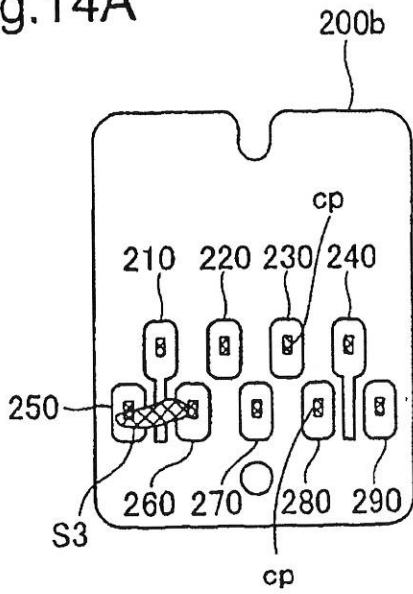

Fig.14B

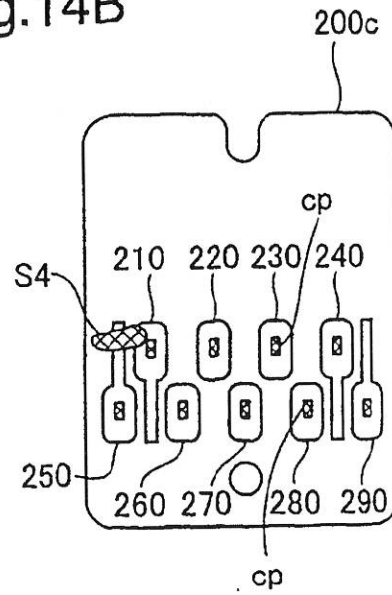

Fig.14C

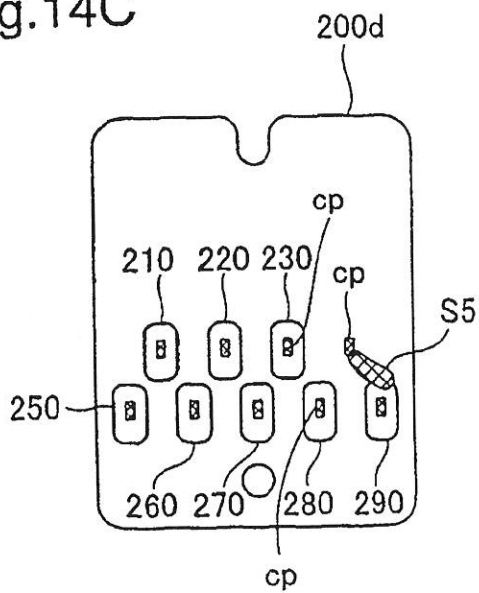

Fig.14D

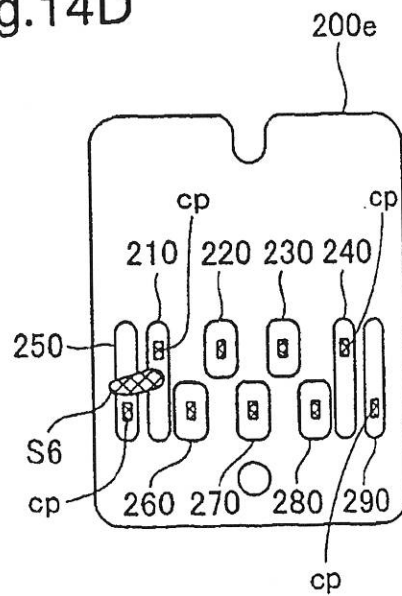

Fig.15A

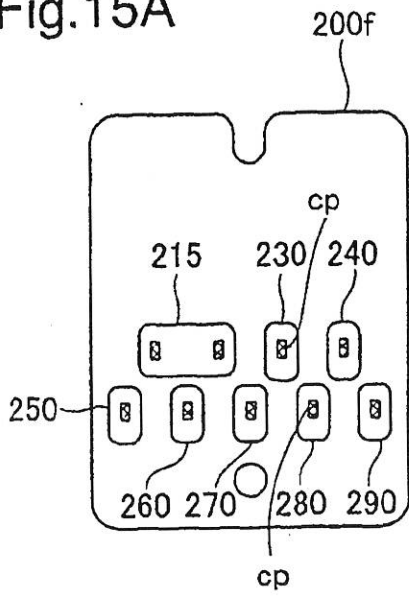

Fig.15B

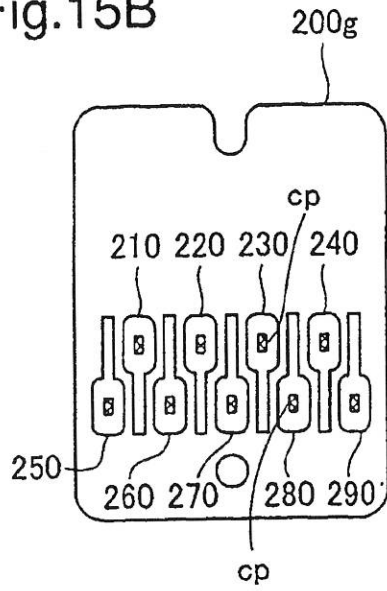

Fig.15C

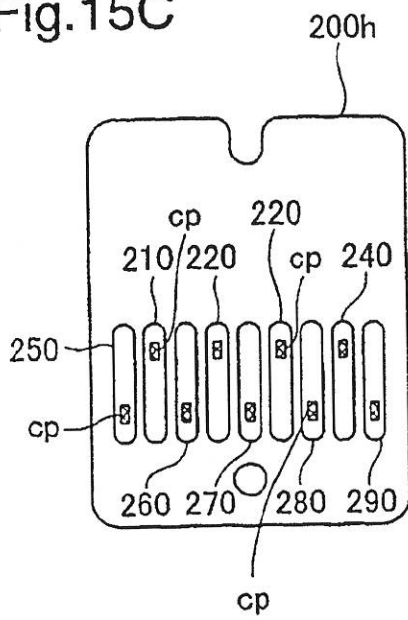

Fig.16A

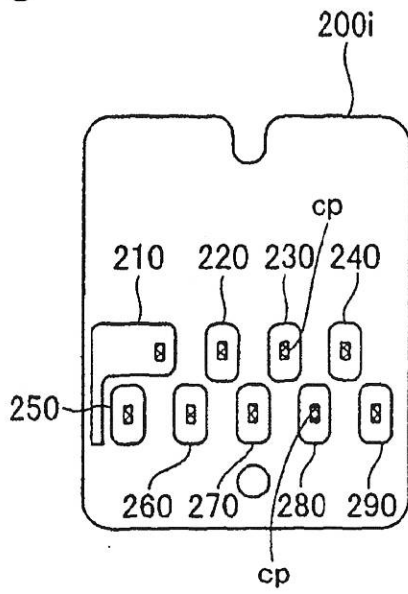

Fig.16B

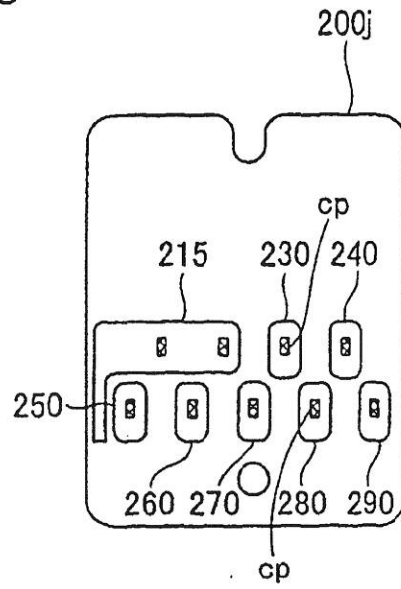

Fig.16C

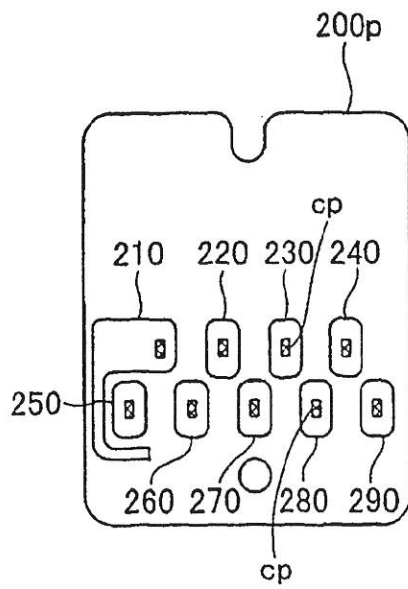

Fig.16D

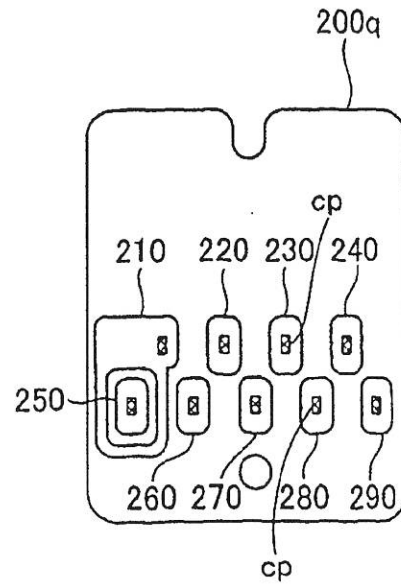

Fig.17A

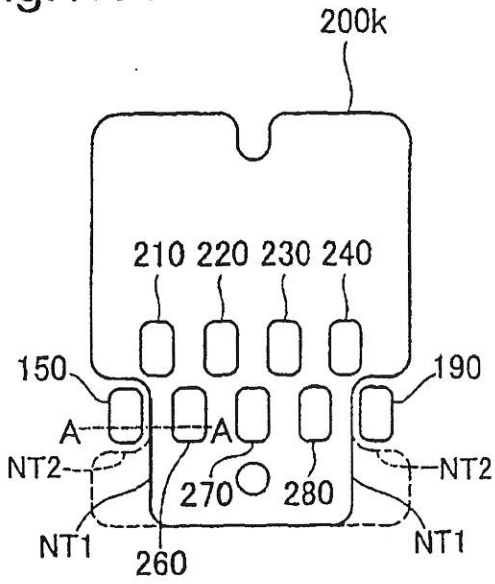

Fig.17B

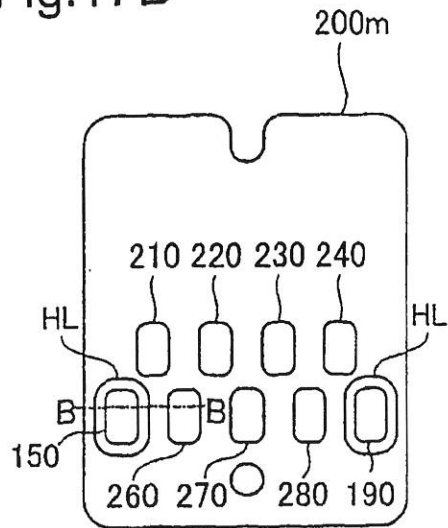

Fig.17C

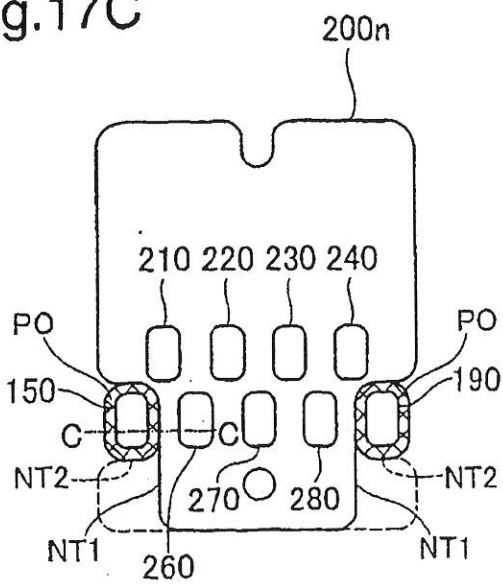

Fig.17D

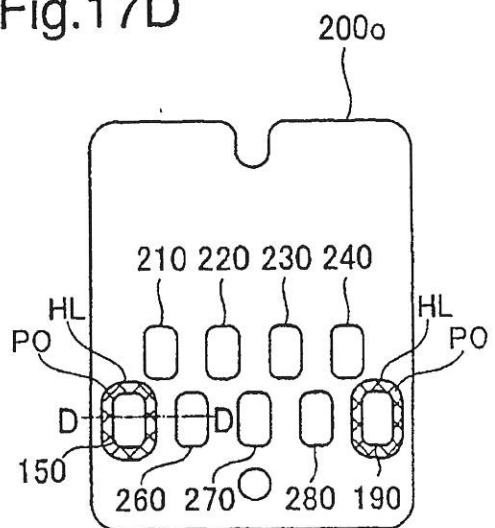

Fig.18A

A-A CROSS SECTION

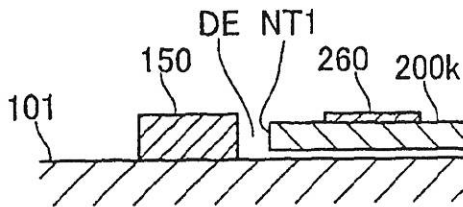

Fig.18B

B-B CROSS SECTION

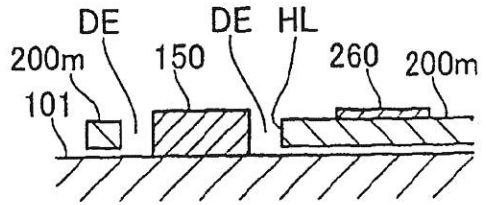

Fig.18C

C-C CROSS SECTION

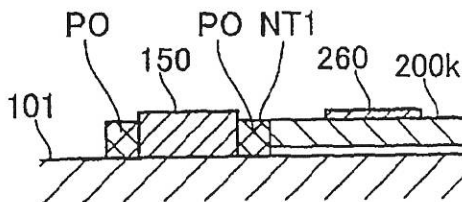

Fig.18D

D-D CROSS SECTION

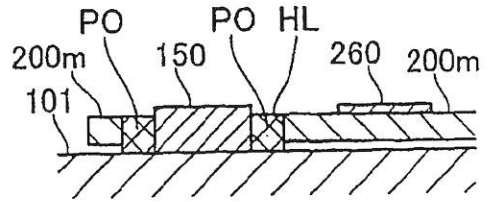

Fig.19A

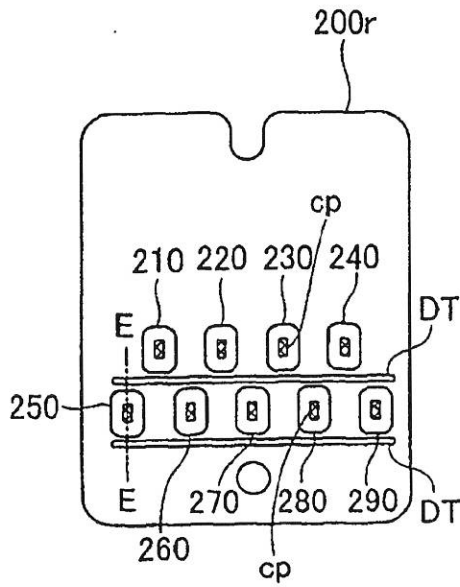

Fig.19B

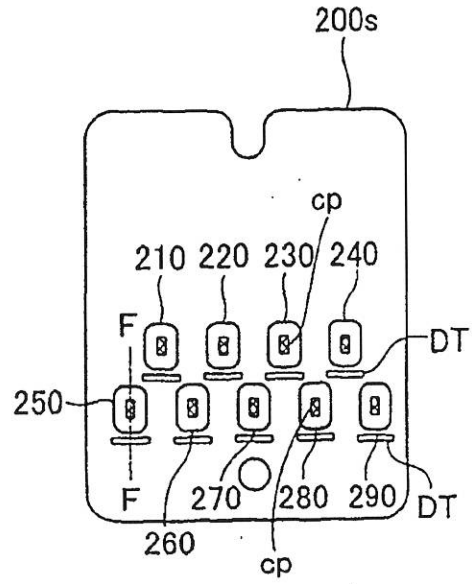

Fig.19C

E-E CROSS SECTION

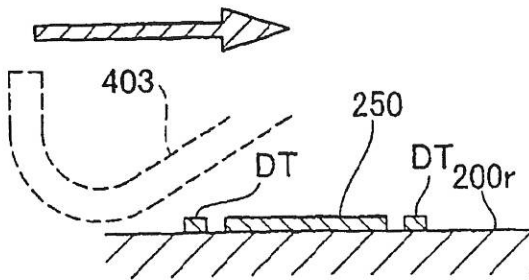

Fig.19D

F-F CROSS SECTION

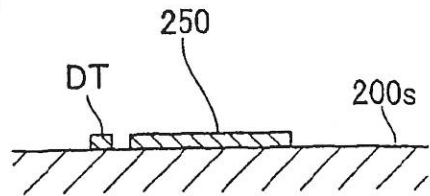
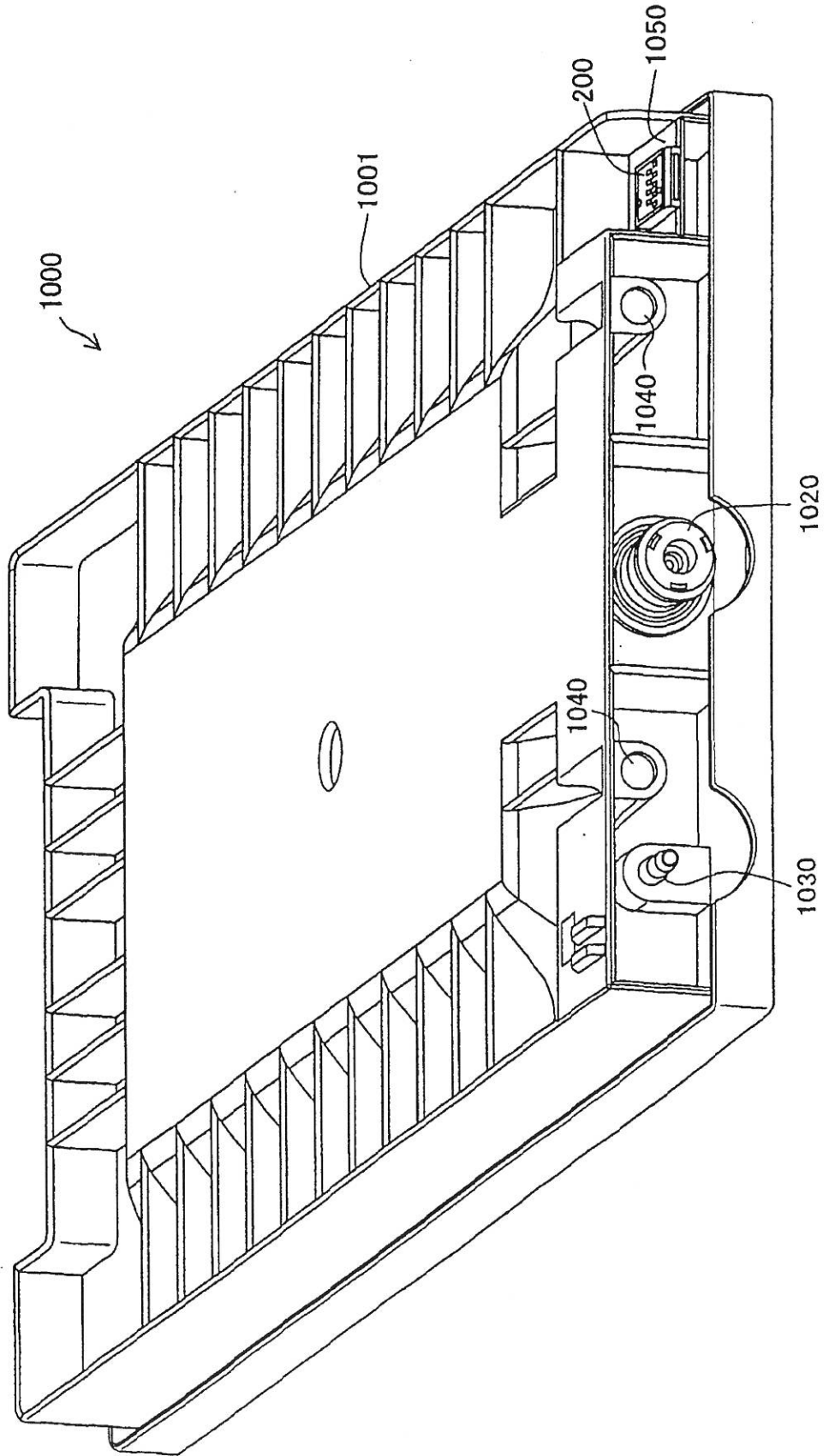

Fig.20



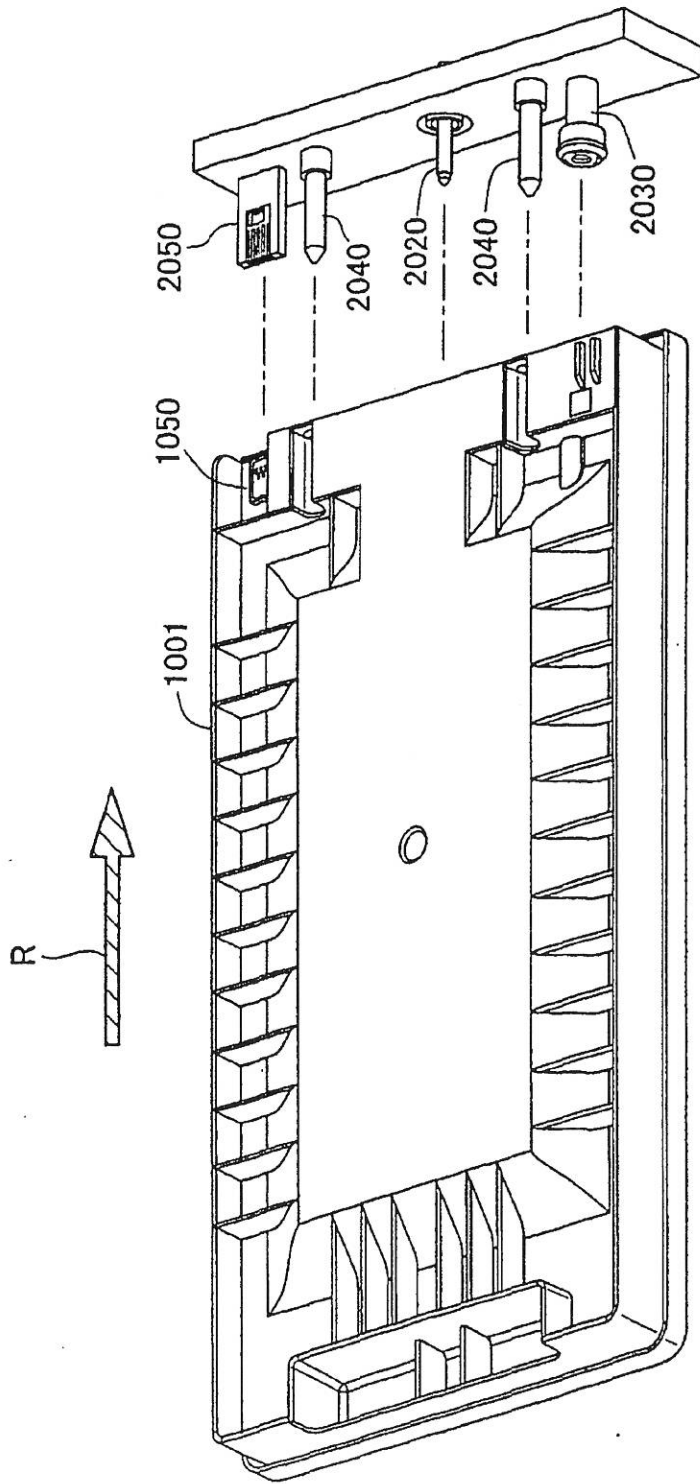

Fig.21

Fig.22

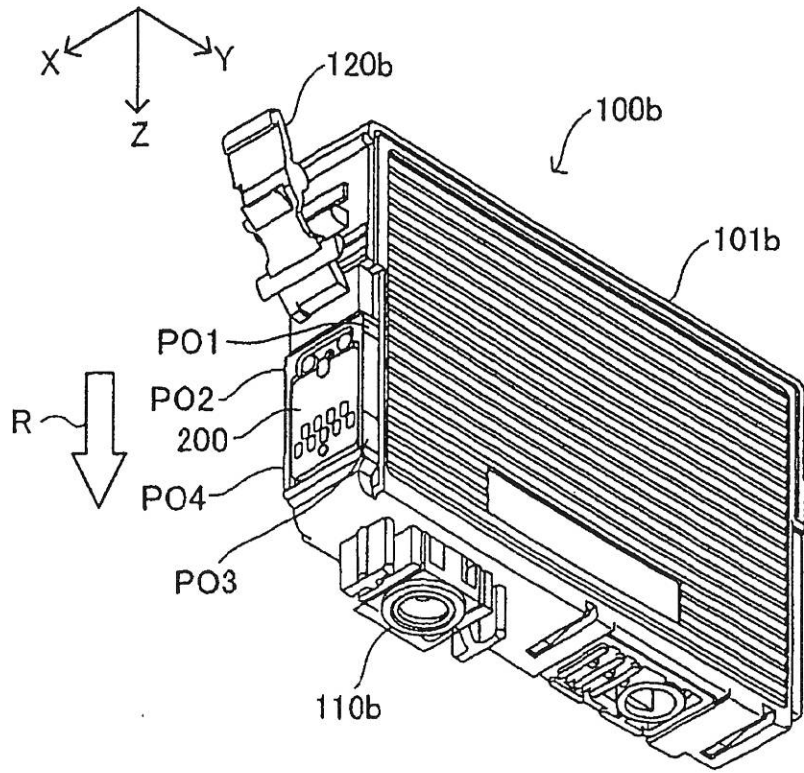

Fig.23

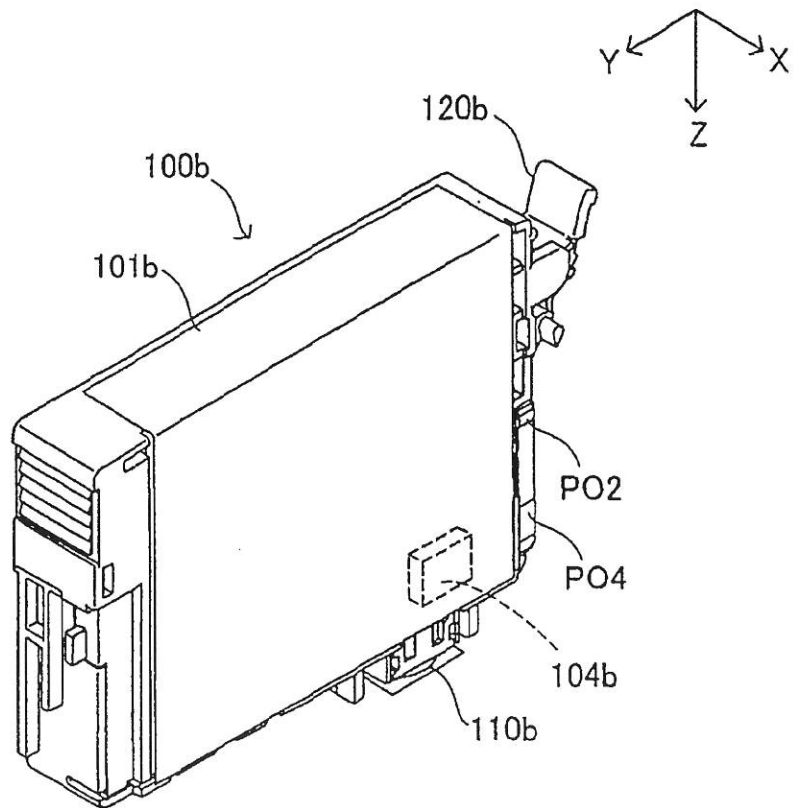
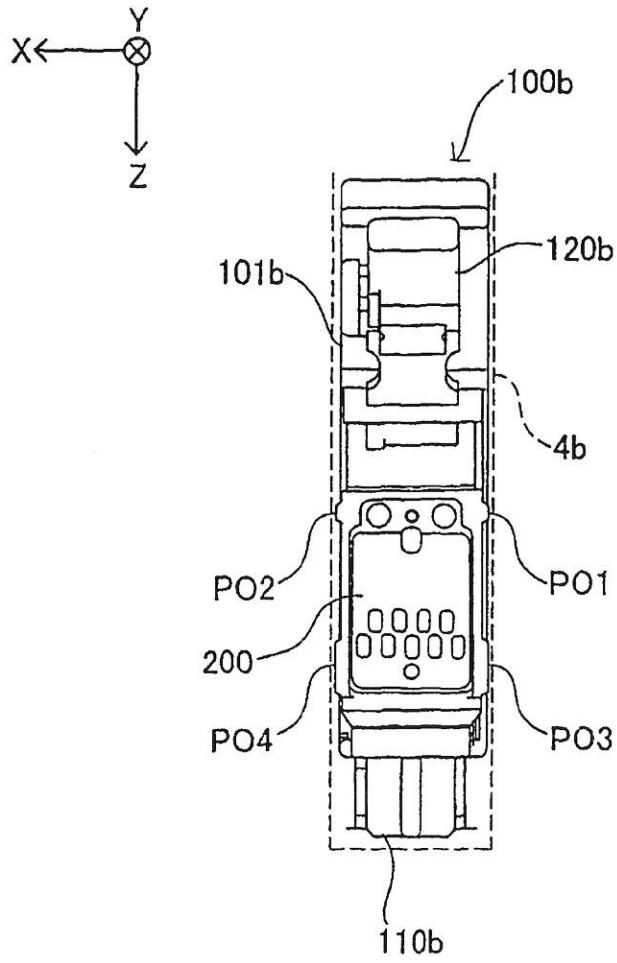

Fig.24



DESCRIPTIONPRINTING MATERIAL CONTAINER, AND BOARD MOUNTED ON PRINTINGMATERIAL CONTAINERTECHNICAL FIELD

[0001] The present invention relates in general to a printing material container containing a printing material and a board mounted on the printing material container, and relates in particular to an arrangement for a plurality of terminals disposed on these components.

BACKGROUND ART

[0002] In recent years, it has become common practice to equip ink cartridges used in ink jet printers or other printing apparatus, with a device, for example, a memory for storing information relating to the ink. Also disposed on such ink cartridges is another device, for example, a high voltage circuit (e.g. a remaining ink level sensor using a piezoelectric element) applied to higher voltage than the driving voltage of the memory. In such cases, there are instances in which the ink cartridge and the printing apparatus are electrically connected through terminals. There is proposed a structure for preventing the information storage medium from shorting and becoming damaged due to a drop of liquid being deposited on the terminals connecting the printing apparatus with the storage medium furnished to the ink cartridge.

[0003] However, the technologies mentioned above do not contemplate an ink cartridge having equipped with a plurality of devices, for example, a memory and a high voltage circuit, with terminals for one device and the terminals for another device. With this kind of cartridge, there was a risk that shorting could occur between a terminal for the one device and the terminal for the another device. Such shorting caused the problem of possible damage to the ink cartridge or to the printing apparatus in which the ink cartridge is attached. This problem is not limited to ink cartridges, but is a problem common to receptacles containing other printing materials, for example, toner.

DISCLOSURE OF THE INVENTION

[0004] An advantage of some aspects of the present invention is to provide a printing material container having a plurality of devices, wherein damage to the printing material container and the printing apparatus caused by shorting between terminals can be prevented or reduced.

~~[0005] A first aspect of the invention provides a printing material container detachably~~
 attachable to a printing apparatus having a plurality of apparatus-side contact forming members, the printing material container comprising:

- a first device;
- a second device; and
- a terminal group that includes a plurality of first terminals and at least one second terminal;

wherein:



~~the plurality of first terminals are connected to the first device and respectively~~
include a first contact portion for contacting a corresponding contact forming member among the plurality of apparatus-side contact forming members,

the at least one second terminal is connected to the second device and includes a second contact portion for contacting a corresponding contact forming member among the plurality of apparatus-side contact forming members,

the printing material container further comprises a short circuit detection contact portion to contact a corresponding contact forming member among the plurality of apparatus-side contact forming members to detect shorting between the second contact portion and the short circuit detection contact portion,

the short circuit detection contact portion is located adjacent to the second contact portion,

the plurality of first contact portions, the second contact portion, and the short circuit detection contact portion are arranged so as to form multiple rows, and

the second contact portion is arranged at an end of one row among the multiple rows.

According to another aspect of the present invention, there is provided a board connectable to a printing apparatus having a plurality of apparatus-side contact forming members, the board comprising:

a first device; and

a terminal group that includes a plurality of first terminals and at least one second terminal;

wherein:

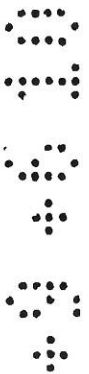

~~the plurality of first terminals are connected to the first device and respectively include a first contact portion for contacting a corresponding contact forming member among the plurality of apparatus-side contact forming members,~~

~~the at least one second terminal is connectable to a second device and includes a second contact portion for contacting a corresponding contact forming member among the plurality of apparatus-side contact forming members,~~

~~the board further comprises a short circuit detection contact portion to contact a corresponding contact forming member among the plurality of apparatus-side contact forming members to detect shorting between the second contact portion and the short circuit detection contact portion,~~

~~the short circuit detection contact portion is located adjacent to the second contact portion,~~

~~the plurality of first contact portions, the second contact portion, and the short circuit detection contact portion are arranged so as to form multiple rows, and~~

~~the second contact portion is arranged at an end of one row among the multiple rows.~~

According to a third aspect of the invention, there is provided a printing material container comprising the board.

According to the printing material container pertaining to the first and third aspects of the invention and board pertaining to the second aspect of the invention, the second contact portion of the second terminal connected to the second device is arranged at one end, whereby other contact portions adjacent to the second contact portions are fewer in number, and consequently the second terminals have less

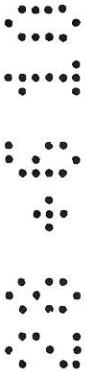

~~likelihood of shorting to terminals include other contact portions. Accordingly, damage to the printing material container/board or printing apparatus caused by such shorting can be prevented or reduced.~~

Moreover, the short circuit detection contact portion is arranged relative to the second terminal. As a result, shorting between the short circuit detection contact portion and the second terminal has a greater tendency to occur than shorting between the first terminal and the second terminal. Accordingly, in the event that the shorting between the first terminal and the second terminal occurs by a drop of ink or foreign matter, it is highly likely that the shorting between the short circuit detection contact portion and the second terminal also occurs, and is detected as anomaly. As a result, damage to the printing material container/board or printing apparatus caused by a shorting between the first terminal and the second terminal can be prevented or reduced.

In either aspect, the second contact portion is preferably located outermost in a row direction of the multiple rows, and the short circuit detection contact portion is preferably located second outermost in the row direction.

Preferably, the second contact portion and a part of the plurality of first contact portions are arranged to form a first row, the short circuit detection contact portion and another part of the plurality of first contact portions are arranged to form a second row, and the first row is longer than the second row, and is situated further in an insertion direction in which the printing material container is detachably attached to the printing apparatus than the second row.

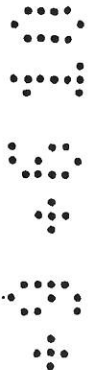

~~Preferably, the number of the first contact portions included in the first row is larger than the number of the first contact portions included in the second row.~~

Preferably, the printing material container comprises two second terminals each having a second contact portion, and the two second contact portions are respectively arranged at each end of the first row.

Preferably, the first device is a memory.

Preferably, the plurality of first terminals consist of a ground terminal, a power supply terminal, a reset terminal, a clock terminal and a data terminal of the memory.



Preferably, the second device is a sensor for determining an amount of printing material contained in the printing material container.



Preferably, the second device is arranged to be operated by a higher voltage than the first device.



Preferably, there is no terminal at the short circuit detection contact portion.

Preferably, the one row among the multiple rows is situated further in an insertion direction in which the printing material container is detachably attached to the printing apparatus than the other rows among the multiple rows.

According to a further aspect of the present invention, there is provided a printing system comprising:

a printing apparatus comprising a plurality of apparatus-side contact forming members; and

~~an above-described printing material container detachably attached to the printing apparatus.~~

According to a further aspect of the present invention, there is provided a printing system comprising:

a printing apparatus comprising a plurality of apparatus-side contact forming members; and

an above-described board detachably attached to the printing apparatus.

Preferably, the apparatus-side contact forming members comprise a plurality of first contact forming members, at least one second contact forming member and at least one short circuit detection contact forming member,

the plurality of first contact forming members are in contact with first contact portions of the printing material container, whereby the first contact forming members are connected to the first device,

the at least one second contact forming member is in contact with the second contact portion, whereby the at least one second contact forming member is connected to the second device, and

the at least one short circuit detection contact forming member is in contact with the short circuit detection contact portion.

Preferably, the printing apparatus further comprises an apparatus-side shorting detection circuit,

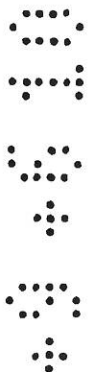

~~and the at least one short circuit detection contact forming member is~~
 connected to the apparatus-side shorting detection circuit to detect shorting between
 the second contact portion and the short circuit detection contact portion.

The present invention also provides in another aspect, a printing material
 container detachably attachable to a printing apparatus having a plurality of apparatus-
 side contact forming members, the printing material container comprising:

a first device;

a second device; and

a terminal group that includes a plurality of first terminals and at least one
 second terminal;

wherein:

the plurality of first terminals are connected to the first device and respectively
 include a first contact portion for contacting a corresponding contact forming member
 among the plurality of apparatus-side contact forming members,

the at least one second terminal is connected to the second device and
 includes a second contact portion for contacting a corresponding contact forming
 member among the plurality of apparatus-side contact forming members,

the printing material container further comprises a short circuit detection
 contact portion to contact a corresponding contact forming member among the plurality
 of apparatus-side contact forming members to detect shorting between the second
 contact portion and the short circuit detection contact portion,

the plurality of first contact portions, the second contact portion, and the short
~~circuit detection contact portion are arranged so as to form two rows,~~



~~the second contact portion is arranged at a first end of a first row among the~~
two rows, and

the short circuit detection contact portion is arranged at a first end of a second row among the two rows,

wherein the first end of the first row and the first end of the second row are located on the same side when viewed from centres of the first row and the second row, respectively.

Preferably, there is no terminal at the short circuit detection contact portion.

Preferably, the first row is situated further in an insertion direction in which the printing material container is detachably attached to the printing apparatus than the second row.

Preferably, the first device is a memory.

Preferably, the second device is arranged to be operated by a higher voltage than the first device.

According to a further aspect of the present invention, there is provided a board connectable to a printing apparatus having a plurality of apparatus-side contact forming members, the board comprising:

a first device; and

a terminal group that includes a plurality of first terminals and at least one second terminal;

wherein:

the plurality of first terminals are connected to the first device and respectively include a first contact portion for contacting a corresponding contact forming member



~~among the plurality of apparatus-side contact forming members,~~

the at least one second terminal is connectable to a second device and includes a second contact portion for contacting a corresponding contact forming member among the plurality of apparatus-side contact forming members,

the board further comprises a short circuit detection contact portion to contact a corresponding contact forming member among the plurality of apparatus-side contact forming members to detect shorting between the second contact portion and the short circuit detection contact portion,

the plurality of first contact portions, the second contact portion, and the short circuit detection contact portion are arranged so as to form two rows,

the second contact portion is arranged at a first end of a first row among the two rows, and

the short circuit detection contact portion is arranged at a first end of a second row among the two rows,

wherein the first end of the first row and the first end of the second row are located on the same side when viewed from centres of the first row and the second row, respectively.

Preferably, the board is not provided with a terminal for the short circuit detection contact portion.

Preferably, the first row is situated further in an insertion direction in which the printing material container is detachably attached to the printing apparatus than the second row.

Preferably, the first device is a memory.

Preferably, the second device is arranged to be operated by a higher voltage than the first device.

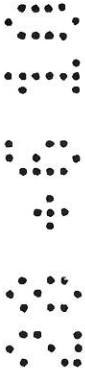

According to a first aspect of the present invention, there is provided a printing material container detachably attachable to a printing apparatus having a print head and a plurality of apparatus-side contact forming members, the printing material container comprising:

- a first device, which is a memory;

- a second device; and

- a terminal group that includes a plurality of first terminals and at least one second terminal;

- wherein:

- the plurality of first terminals are connected to the first device and respectively include a first contact portion for contacting a corresponding contact forming member among the plurality of apparatus-side contact forming members,

- the at least one second terminal is connected to the second device and includes a second contact portion for contacting a corresponding contact forming member among the plurality of apparatus-side contact forming members,

- the printing material container further comprises a short circuit detection contact portion to contact a corresponding contact forming member among the plurality of apparatus-side contact forming members to detect shorting between the second contact portion and the short circuit detection contact portion,

- the at least one second terminal is arranged to have a higher voltage applied thereto than the plurality of first terminals,

- the second device is operated by a higher voltage than the first device,

- the short circuit detection contact portion is located adjacent to the second contact portion,

- the plurality of first contact portions, the second contact portion, and the short circuit detection contact portion are arranged so as to form multiple rows, and

- the second contact portion is arranged at an end of one row among the multiple rows.

According to another aspect of the present invention, there is provided a board connectable to a printing apparatus having a print head and a plurality of apparatus-side contact forming members, the board comprising:

a first device, which is a memory; and
a terminal group that includes a plurality of first terminals and at least one second terminal;

wherein:

the plurality of first terminals are connected to the first device and respectively include a first contact portion for contacting a corresponding contact forming member among the plurality of apparatus-side contact forming members,

the at least one second terminal is connectable to a second device and includes a second contact portion for contacting a corresponding contact forming member among the plurality of apparatus-side contact forming members,

the board further comprises a short circuit detection contact portion to contact a corresponding contact forming member among the plurality of apparatus-side contact forming members to detect shorting between the second contact portion and the short circuit detection contact portion,

the at least one second terminal is arranged to have a higher voltage applied thereto than the plurality of first terminals,

the second device is operated by a higher voltage than the first device,

the short circuit detection contact portion is located adjacent to the said second contact portion,

the plurality of first contact portions, the second contact portion, and the short circuit detection contact portion are arranged so as to form multiple rows, and

the second contact portion is arranged at an end of one row among the multiple rows.

According to a third aspect of the invention, there is provided a printing material container comprising the board.

According to the printing material container pertaining to the first and third aspects of the invention and board pertaining to the second aspect of the invention, the second contact portion of the second terminal connected to the second device is arranged at one end, whereby other contact portions adjacent to the second contact portion are fewer in number, and consequently the second terminals have less likelihood

of shorting to terminals including other contact portions. Accordingly, damage to the printing material container/board or printing apparatus caused by such shorting can be prevented or reduced.

Moreover, the short circuit detection contact portion is arranged relative to the second terminal. As a result, shorting between the short circuit detection contact portion and the second terminal has a greater tendency to occur than shorting between the first terminal and the second terminal. Accordingly, in the event that the shorting between the first terminal and the second terminal occurs by a drop of ink or foreign matter, it is highly likely that the shorting between the short circuit detection contact portion and the second terminal also occurs, and is detected as an anomaly. As a result, damage to the printing material container/board or printing apparatus caused by a shorting between the first terminal and the second terminal can be prevented or reduced.

In either aspect, the second contact portion is preferably located outermost in a row direction of the multiple rows, and the short circuit detection contact portion is located second outermost in the row direction.

Preferably, the second contact portion and a part of the plurality of first contact portions are arranged to form a first row, the short circuit detection contact portion and another part of the plurality of first contact portions are arranged to form a second row, and the first row is longer than the second row, and is situated further in an insertion direction in which the printing material container is detachably attached to the printing apparatus than the second row.

Preferably, the number of the first contact portions included in the first row is larger than the number of the first contact portions included in the second row.

Preferably, the printing material container comprises two second terminals each having a second contact portion, and the two second contact portions are respectively arranged at each end of one row among the multiple rows.

Preferably, the plurality of first terminals consist of a ground terminal, a power supply terminal, a reset terminal, a clock terminal and a data terminal of the memory.

Preferably, the first contact portions consist of contact portions of a ground terminal, a power supply terminal, a reset terminal, a clock terminal and a data terminal of the memory.

Preferably, the second device is a sensor for determining an amount of printing material contained in the printing material container.

Preferably, there is no terminal at the short circuit detection contact portion.

Preferably, the one row among the multiple rows is situated further in an insertion direction in which the printing material container is detachably attached to the printing apparatus than the other rows among the multiple rows.

According to a further aspect of the present invention, there is provided a printing system comprising:

a printing apparatus comprising a plurality of apparatus-side contact forming members; and

an above-described printing material container detachably attached to the printing apparatus.

According to a further aspect of the present invention, there is provided a printing system comprising:

a printing apparatus comprising a plurality of apparatus-side contact forming members; and

an above-described board detachably attached to the printing apparatus.

Preferably, the apparatus-side contact forming members comprise a plurality of first contact forming members, at least one second contact forming member and at least one short circuit detection contact forming member,

the plurality of first contact forming members are in contact with first contact portions of the printing material container, whereby the first contact forming members are connected to the first device,

the at least one second contact forming member is in contact with the second contact portion, whereby the at least one second contact forming member is connected to the second device, and

the at least one short circuit detection contact forming member is in contact with the short circuit detection contact portion.

Preferably, the printing apparatus further comprises an apparatus-side shorting detection circuit,

and the at least one short circuit detection contact forming member is connected to the apparatus-side shorting detection circuit to detect shorting between the second contact portion and the short circuit detection contact portion.

The present invention also provides in another aspect a printing material container detachably attachable to a printing apparatus having a print head and a plurality of apparatus-side contact forming members, the printing material container comprising:

a first device, which is a memory;

a second device; and

a terminal group that includes a plurality of first terminals and at least one second terminal;

wherein:

the plurality of first terminals are connected to the first device and respectively include a first contact portion for contacting a corresponding contact forming member among the plurality of apparatus-side contact forming members,

the at least one second terminal is connected to the second device and includes a second contact portion for contacting a corresponding contact forming member among the plurality of apparatus-side contact forming members,

the printing material container further comprises a short circuit detection contact portion to contact a corresponding contact forming member among the plurality of apparatus-side contact forming members to detect shorting between the second contact portion and the short circuit detection contact portion,

the at least one second terminal is arranged to have a higher voltage applied thereto than the plurality of first terminals,

the second device is operated by a higher voltage than the first device,

the plurality of first contact portions, the second contact portion, and the short circuit detection contact portion are arranged so as to form two rows,

the second contact portion is arranged at a first end of a first row among the two rows, and

the short circuit detection contact portion is arranged at a first end of a second row among the two rows,

wherein the first end of the first row and the first end of the second row are located on the same side when viewed from centres of the first row and the second row, respectively.

Preferably, there is no terminal at the short circuit detection contact portion.

Preferably, the first row is situated further in an insertion direction in which the printing material container is detachably attached to the printing apparatus than the second row.

According to a further aspect of the present invention, there is provided a board connectable to a printing apparatus having a print head and a plurality of apparatus-side contact forming members, the board comprising:

a first device, which is a memory; and

a terminal group that includes a plurality of first terminals and at least one second terminal;

wherein:

the plurality of first terminals are connected to the first device and respectively include a first contact portion for contacting a corresponding contact forming member among the plurality of apparatus-side contact forming members,

the at least one second terminal is connectable to a second device and includes a second contact portion for contacting a corresponding contact forming member among the plurality of apparatus-side contact forming members,

the board further comprises a short circuit detection contact portion to contact a corresponding contact forming member among the plurality of apparatus-side contact forming members to detect shorting between the second contact portion and the short circuit detection contact portion,

the at least one second terminal is arranged to have a higher voltage applied thereto than the plurality of first terminals,

the second device is operated by a higher voltage than the first device,

the plurality of first contact portions, the second contact portion, and the short circuit detection contact portion are arranged so as to form two rows,

the second contact portion is arranged at a first end of a first row among the two rows, and

the short circuit detection contact portion is arranged at a first end of a second row among the two rows,

wherein the first end of the first row and the first end of the second row are located on the same side when viewed from centres of the first row and the second row, respectively.

Preferably, the board is not provided with a terminal for the short circuit detection contact portion.

Preferably, the first row is situated further in an insertion direction in which the printing material container is detachably attached to the printing apparatus than the second row.

The above and other objects, characterizing features, aspects and advantages of the present invention will be clear from the description of preferred embodiments presented below along with the attached figures.

BRIEF DESCRIPTION OF THE DRAWINGS

FIG. 1 shows a perspective view of the construction of the printing apparatus pertaining to an embodiment of the invention;

FIG. 2 shows a perspective view of the construction of the ink cartridge pertaining to the embodiment;

FIGS. 3A-B show diagrams of the construction of the board pertaining to the embodiment;

FIG. 4 shows an illustration showing attachment of the ink cartridge in the holder;

FIG. 5 shows an illustration showing the ink cartridge attached to the holder;

FIGS. 6A-B show schematics of the construction of the contact mechanism;

FIG. 7 shows a brief diagram of the electrical arrangement of the ink cartridge and the printing apparatus;

FIG. 8 shows a brief diagram of the electrical arrangement, focusing on the cartridge detection/short detection circuit;

FIG. 9 shows a flowchart depicting the processing routine of the cartridge determination process;

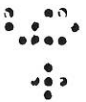
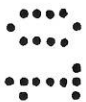

FIGS. 10A-C show illustrations depicting three types of terminal lines on the board;

FIG. 11 shows a flowchart depicting the processing routine of the remaining ink level detection process;

FIGS. 12A-C show timing charts depicting temporal change in the shorting-detection enable signal and sensor voltage during execution of the remaining ink level detection process;

FIG. 13 shows an illustration of a scenario of shorting;

FIGS. 14A-D show first diagrams depicting boards pertaining to variations;

FIGS. 15A-C show second diagrams depicting boards pertaining to variations;

FIGS. 16A-D show third diagrams depicting boards pertaining to variations;

FIGS. 17A-D show diagrams depicting the construction around boards of ink cartridges pertaining to variations;

FIGS. 18A-D show cross sections A-A to D-D in FIG. 17;

FIGS. 19A-D show fourth diagrams depicting boards pertaining to variations;

FIG 20 shows a perspective view of the construction of the ink cartridge pertaining to a variation;

FIG 21 shows a picture of the ink cartridge pertaining to a variation being attached to the printer;

FIG 22 shows a first diagram of the construction of the ink cartridge pertaining to a variation;

FIG 23 shows a second diagram of the construction of the ink cartridge pertaining to a variation;

FIG 24 shows a third diagram of the construction of the ink cartridge pertaining to a variation.

BEST MODES OF CARRYING OUT THE INVENTION

[0024] Embodiments of the present invention will be described below with reference to the drawings.

[0025] A. Embodiment

Arrangement of Printing apparatus and Ink Cartridge:

FIG. 1 shows a perspective view of the construction of the printing apparatus pertaining to an embodiment of the invention. The printing apparatus 1000 has a sub-scan feed mechanism, a main scan feed mechanism, and a head drive mechanism. The sub-scan feed mechanism carries the printing paper P in the sub-scanning direction using a paper feed roller 10 powered by a paper feed motor, not shown. The main scan feed mechanism uses the power of a carriage motor 2 to reciprocate in the main scanning direction a carriage 3 connected to a drive belt. The head drive mechanism drives a print head 5 mounted on the carriage 3, to eject ink and form dots. The printing apparatus 1000 additionally comprises a main

control circuit 40 for controlling the various mechanisms mentioned above. The main control circuit 40 is connected to the carriage 3 via a flexible cable 37.

[0026] The carriage 3 comprises a holder 4, the print head 5 mentioned above, and a carriage circuit, described later. The holder 4 is designed for attachment of a number of ink cartridges, described later, and is situated on the upper face of the print head 5. In the example depicted in FIG. 1, the holder 4 is designed for attachment of four ink cartridges, e.g. individual attachment of four types of ink cartridge containing black, yellow, magenta, and cyan ink. Four openable and closable covers 11 are attached to the holder 4 for each attached ink cartridge. Also disposed on the upper face of the print head 5 are ink supply needles 6 for supplying ink from the ink cartridges to the print head 5.

[0027] The construction of the ink cartridge pertaining to the embodiment will now be described with reference of FIGS. 2 -5. FIG. 2 shows a perspective view of the construction of the ink cartridge pertaining to the embodiment. FIGS. 3A-B show diagrams of the construction of the board pertaining to the embodiment. FIG. 4 shows an illustration showing attachment of the ink cartridge in the holder. FIG. 5 shows an illustration showing the ink cartridge attached to the holder. The ink cartridge 100 attached to the holder 4 comprises a housing 101 containing ink, a lid 102 providing closure to the opening of the housing 101, a board 200, and a sensor 104. On the bottom face of the housing 101 there is formed an ink supply orifice 110 into which the aforementioned ink supply needle 6 inserts when ink cartridge 100 is attached to the holder 4. At the upper edge of the front face FR of

the housing 101 there is formed a flared section 103. On the lower side of the center of the front face FR of the housing 101 there is formed a recess 105 bounded by upper and lower ribs 107, 106. The aforementioned board 200 fits into this recess 105. The sensor 104 is located in the region posterior to the board 200. The sensor 104 is used to detect remaining ink level, as will be described later.

[0028] FIG. 3A depicts the arrangement on the surface of the board 200. This surface is the face that is exposed to the outside when the board 200 is mounted on the ink cartridge 100. FIG. 3B depicts the board 200 viewed from the side. A boss slot 201 is formed at the upper edge of the board 200, and a boss hole 202 is formed at the lower edge of the board 200. As shown in FIG. 1, with the board 200 attached to the recess 105 of the housing 101, bosses 108 and 109 formed on the lower face of the recess 105 mate with the boss slot 201 and the boss hole 202 respectively. The distal ends of the bosses 108 and 109 are crushed to effect caulking. The board 200 is secured within the recess 105 thereby.

[0029] The following description of attachment of the ink cartridge 100 makes reference to FIG. 4 and FIG. 5. As depicted in FIG. 4, the cover 11 is designed to be rotatable about a rotating shaft 9. With the cover 11 rotated upward to the open position, when the ink cartridge 100 is being attached to the holder, the flared section 103 of the ink cartridge is received by a projection 14 of the cover 11. When the cover 11 is closed from this position, the projection 14 rotates downward, and the ink cartridge 100 descends downward (in the Z direction in FIG. 4). When the cover 11 is completely closed, a hook 18 of the cover 11

interlocks with a hook 16 of the holder 4. With the cover 11 completely closed, the ink cartridge 100 is secured pressed against the holder 4 by an elastic member 20. Also, with the cover 11 completely closed, the ink supply needle 6 inserts into the ink supply orifice 110 of the ink cartridge 100, and the ink contained in the ink cartridge 100 is supplied to the printing apparatus 1000 via the ink supply needle 6. As will be apparent from the preceding description, the ink cartridge 100 is attached to the holder 4 by means of inserting it so as to move in the forward direction of the Z axis in FIG. 4 and FIG. 5. The forward direction of the Z axis in FIG. 4 and FIG. 5 shall also be referred to as insertion direction of the ink cartridge 100.

[0030] Returning to FIG. 3, the board 200 shall be described further. The arrow R in FIG. 3 (a) indicates the insertion direction of the ink cartridge 100 discussed above. As depicted in FIG. 3, the board 200 comprises a memory 203 disposed on its back face, and a terminal group composed of nine terminals 210 -290 disposed on its front face. The memory 203 stores information relating to the ink contained in the ink cartridge 100. The terminals 210 -290 are generally rectangular in shape, and are arranged in two rows generally orthogonal to the insertion direction R. Of the two rows, the row on the insertion direction R side, i.e. the row situated on the lower side in FIG. 3 (a), shall be termed the lower row, and the row on the opposite side from the insertion direction R, i.e. the row situated on the upper side in FIG. 3 (a), shall be termed the upper row. The terminals arranged so as to form the upper row consist, in order from left in FIG. 3 (a), of a first short detection

terminal 210, a ground terminal 220, a power supply terminal 230, and a second short detection terminal 240. The terminals arranged so as to form the lower row consist, in order from left in FIG. 3 (a), of a first sensor drive terminal 250, a reset terminal 260, a clock terminal 270, a data terminal 280, and a second sensor drive terminal 290. As depicted in FIG. 3, each of the terminals 210 -290 contains in its center portion a contact portion CP for contacting a corresponding terminal among the plurality of apparatus-side terminals, described later.

[0031] The terminals 210 -240 forming the upper row and the terminals 250 -290 forming the lower row are arranged differently from one another, constituting a so-called staggered arrangement, so that the terminal centers do not line up with one another in the insertion direction R. As a result, the contact portions CP of the terminals 210 -240 forming the upper row and the contact portions CP of the terminals 250 -290 forming the lower row are similarly arranged differently from one another, constituting a so-called staggered arrangement.

[0032] As will be appreciated from FIG. 3A, the first sensor drive terminal 250 is situated adjacently to two other terminals (the reset terminal 260 and the first short detection terminal 210), and of these, the first short detection terminal 210 for detecting shorting is positioned closest to the first sensor drive terminal 250. Similarly, the second sensor drive terminal 290 is situated adjacently to two other terminals (the second short detection terminal 240 and the data terminal 280), and of these, the second short detection terminal 240 for detecting shorting is positioned closest to the second sensor drive terminal 290.

[0033] With regard to relationships among the contact portions CP, the contact portion CP of the first sensor drive terminal 250 is situated adjacently to the contact portions CP of two other terminals (the reset terminal 260 and the first short detection terminal 210). Similarly, the contact portion CP of the second sensor drive terminal 290 is situated adjacently to the contact portions CP of two other terminals (the second short detection terminal 240 and the data terminal 280).

[0034] As will be appreciated from FIG. 3A, the first sensor drive terminal 250 and the second sensor drive terminal 290 are situated at the ends of the lower row, i.e. at the outermost positions in the lower row. The lower row is composed of a greater number of terminals than the upper row, and the length of the lower row in the direction orthogonal to the insertion direction R is greater than the length of the upper row, and consequently of all the terminals 210 -290 contained in the upper and lower rows, the first sensor drive terminal 250 and the second sensor drive terminal 290 are situated at the outermost positions viewed in the direction orthogonal to the insertion direction R.

[0035] With regard to relationships among the contact portions CP, the contact portion CP of the first sensor drive terminal 250 and the contact portion CP of the second sensor drive terminal 290 are respectively situated at the ends of the lower row formed by the contact portions CP of the terminals, i.e., at the outermost positions in the lower row. Among the contact portions of all the terminals 210 -290 contained in the upper and lower rows, the contact portion CP of the first sensor

drive terminal 250 and the contact portion CP of the second sensor drive terminal 290 are situated at the outermost positions viewed in the direction orthogonal to the insertion direction R.

[0036] As will be appreciated from FIG. 3A, the first short detection terminal 210 and the second short detection terminal 240 are respectively situated at the ends of the upper row, i.e., at the outermost positions in the upper row. As a result, the contact portion CP of the first short detection terminal 210 and the contact portion CP of the second short detection terminal 240 are similarly located at the ends of the upper row formed by the contact portions CP of the terminals, i.e. at the outermost positions in the upper row. Consequently, as will be discussed later, the terminals 220, 230, 260, 270 and 280 connected to the memory 203 are situated between the first short detection terminal 210 and the first sensor drive terminal 250, and the second short detection terminal 240 and the second sensor drive terminal 290, located to either side.

[0037] In the embodiment, the board 200 has width of approximately 12.8 mm in the insertion direction R, width of the approximately 10.1 mm in the direction orthogonal to the insertion direction R, and thickness of approximately 0.71 mm. The terminals 210 -290 each have width of approximately 1.8 mm in the insertion direction R and width of approximately 1.05 mm in the direction orthogonal to the insertion direction R. The dimension values given here are merely exemplary, with differences on the order of ± 0.5 mm being acceptable, for example. The spacing between adjacent terminals in a given row (the lower row or the upper row), for

example the interval K between the first short detection terminal 210 and the ground terminal 220, is 1 mm for example. With regard to spacing among terminals, differences on the order of ± 0.5 mm are acceptable, for example. The interval J between the upper row and the lower row is about 0.2 mm. With regard to spacing among rows, differences on the order of ± 0.3 mm are acceptable, for example.

[0038] As depicted in FIG. 5, with the ink cartridge 100 attached completely within the holder 4, the terminals 210 -290 of the board 200 are electrically connected to a carriage circuit 500 via a contact mechanism 400 disposed on the holder 4. The contact mechanism 400 shall be described briefly making reference to FIGS. 6A-B.

[0039] FIGS. 6A-B show schematics of the construction of the contact mechanism 400. The contact mechanism 400 has multiple slits 401, 402 of two types that differ in depth, formed in alternating fashion at substantially constant pitch in correspondence with the terminals 210 -290 on the board 200. Within each slit 401, 402 there fits a contact forming member 403, 404 endowed with electrical conductivity and resistance. Of the two ends of each contact forming member 403 and 404, the end exposed to the inside of the holder is placed in resilient contact with a corresponding terminal among the terminals 210 -290 on the board 200. In FIG. 6A, portions 410 -490 which are the portions of the contact forming members 403 and 404 that contact the terminals 210 -290 are shown. Specifically, the portions 410 -490 that contact the terminals 210 -290 function as apparatus-side

terminals for electrically connecting the printing apparatus 1000 with the terminals 210 -290. The portions 410 -490 that contact the terminals 210 -290 shall hereinafter be termed apparatus-side terminals 410 -490. With the ink cartridge 100 attached to the holder 4, the apparatus-side terminals 410 -490 respectively contact the contact portions CP of the terminals 210 -290 described above (FIG. 3A).

[0040] On the other hand, of the two ends of each contact forming member 403 and 404, the end lying exposed on the exterior of the holder 4 is placed in resilient contact with a corresponding terminal among the terminals 510 -590 furnished to the carriage circuit 500.

[0041] The electrical arrangements of the ink cartridge 100 and the printing apparatus will now be described, focusing on the part relating to the ink cartridge 100, with reference to FIG. 7 and FIG. 8. FIG. 7 shows a brief diagram of the electrical arrangement of the ink cartridge and the printing apparatus. FIG. 8 shows a brief diagram of the electrical arrangement, focusing on the cartridge detection/short detection circuit.

[0042] First, the electrical arrangement of the ink cartridge 100 shall be described. Of the terminals of the board 200 described with reference to FIG. 3, the ground terminal 220, the power supply terminal 230, the reset terminal 260, the clock terminal 270 and the data terminal 280 are electrically connected to the memory 203. The memory 203 is, for example, EEPROM comprising serially accessed memory cells, and performing data read/write operations in sync with a

clock signal. The ground terminal 220 is grounded via a terminal 520 on the printing apparatus 1000 side. The reset terminal 260 is electrically connected to a terminal 560 of the carriage circuit 500, and is used to supply a reset signal RST to the memory 203 from the carriage circuit 500. The clock terminal 270 is electrically connected to a terminal 570 of the carriage circuit 500, and is used to supply the clock signal CLK to the memory 203 from the carriage circuit 500. The data terminal 280 is electrically connected to a terminal 580 of the carriage circuit 500, and is used for exchange of data signals SDA between the carriage circuit 500 and the memory 203.

[0043] Of the terminals of the board 200 described with reference to FIG. 3, either the first short detection terminal 210, the second short detection terminal 240, or both are electrically connected with the ground terminal 220. In the example depicted in FIG. 7, it will be apparent that the first short detection terminal 220 is electrically connected to the ground terminal 220. The first short detection terminal 210 and the second short detection terminal 240 are electrically connected respectively to the terminals 510, 540 of the carriage circuit 500, and used for cartridge detection and short detection, described later.

[0044] In the embodiment, a piezoelectric element is used as the sensor 104. The remaining ink level can be detected by applying driving voltage to the piezoelectric element to induce the piezoelectric element to vibrate through the inverse piezoelectric effect, and measuring the vibration frequency of the voltage produced by the piezoelectric effect of the residual vibration. Specifically, this

vibration frequency represents the characteristic frequency of the surrounding structures (.e.g. the housing 101 and ink) that vibrate together with the piezoelectric element. The characteristic frequency changes depending on the amount of ink remaining within the ink cartridge, so the remaining ink level can be detected by measuring this vibration frequency. Of the terminals of the board 200 described with reference to FIG. 3, the second sensor drive terminal 290 is electrically connected to one electrode of the piezoelectric element used as the sensor 104, and the first sensor drive terminal 250 is electrically connected to the other electrode. These terminals 250, 290 are used for exchange of sensor driving voltage and output signals from the sensor 104, between the carriage circuit 500 and the sensor 104.

[0045] The carriage circuit 500 comprises a memory control circuit 501, a cartridge detection/short detection circuit 502, and a sensor driving circuit 503. The memory control circuit 501 is a circuit connected to the terminals 530, 560, 570, 580 of the carriage circuit 500 mentioned above, and used to control the memory 203 of the ink cartridge 100 to perform data read/write operations. The memory control circuit 501 and the memory 203 are low-voltage circuits driven at relatively low voltage (in the embodiment, a maximum of about 3.3 V). The memory control circuit 501 can employ a known design, and as such need not be described in detail here.

[0046] The sensor driving circuit 503 is a circuit connected to the terminals 590 and 550 of the carriage circuit 500, and used to control the driving voltage output

from these terminals 590 and 550 to drive the sensor 104, causing the sensor 104 to detect the remaining ink level. As will be described later, the driving voltage has a generally trapezoidal shape, and contains relatively high voltage (in the embodiment, about 36 V). Specifically, the sensor driving circuit 503 and the sensor 104 are high-voltage circuits using relatively high voltage via the terminals 590 and 550. The sensor driving circuit 503 is composed of a logic circuit for example, but need not be described in detail herein.

[0047] The cartridge detection/short detection circuit 502, like the memory control circuit 501, is a low-voltage circuit driven using relatively low voltage (in the embodiment, a maximum of about 3.3V). As depicted in FIG. 8, the cartridge detection/short detection circuit 502 comprises a first detection circuit 5021 and a second detection circuit 5022. The first detection circuit 5021 is connected to the terminal 510 of the carriage circuit 500. The first detection circuit 5021 has a cartridge detection function for detecting whether there is contact between the terminal 510 and the first short detection terminal 210 of the board 200, and a short detection function for detecting shorting of the terminal 510 to the terminals 550 and 590 which output high voltage.

[0048] To describe in more specific terms, the first detection circuit 5021 has a reference voltage V_{ref1} applied to one end of two series-connected resistors R2, R3, with the other end being grounded, thereby maintaining the potential at point P1 and P2 in FIG. 4 at V_{ref1} and V_{ref2} , respectively. Herein V_{ref1} shall be termed the short detection voltage, and V_{ref2} shall be termed the cartridge

detection voltage. In the embodiment, the short detection voltage V_{ref1} is set to 6.5 V, and the cartridge detection voltage V_{ref2} is set to 2.5 V. These values are established by means of the circuits, and are not limited to the values given herein.

[0049] As depicted in FIG. 8, the short detection voltage V_{ref1} (6.5 V) is input to the negative input pin of a first Op-Amp OP1, while the cartridge detection voltage V_{ref2} (2.5 V) is input to the negative input pin of a second Op-Amp OP2. The potential of the terminal 510 is input to the positive input pins of the first Op-Amp OP1 and the second Op-Amp OP2. These two Op-Amps function as a comparator, outputting a High signal when the potential input to the negative input pin is higher than the potential input to the positive input pin, and conversely outputting a Low signal when the potential input to the negative input pin is lower than the potential input to the positive input pin.

[0050] As depicted in FIG. 8, the terminal 510 is connected to a 3.3 V power supply VDD 3.3 via a transistor TR1. By means of this arrangement, if terminal 510 is free e.g. there is no contact with terminal 510, the potential of the terminal 510 will be set at about 3 V. As noted, when the ink cartridge 100 is attached, the terminal 510 comes into contact with the first short detection terminal 210 of the board 200 described previously. Here, as depicted in FIG. 7, with the first short detection terminal 210 and the ground terminal 220 electrically connected (shorted) in the board 200, when the terminal 510 comes into contact with the first short detection terminal 210 (herein referred to as being in contact), the terminal

510 is electrically continuous with the grounded terminal 520, and the potential of the terminal 510 drops to 0 V.

[0051] Consequently, with the terminal 510 free, a High signal from the second Op-Amp OP2 is output as the cartridge detection signal CS1. With the terminal 510 in contact, a Low signal from the second Op-Amp OP2 is output as the cartridge detection signal CS1.[0052] On the other hand, if the terminal 510 is shorted to the adjacent terminal 550, there are instances in which the sensor driving voltage (45 V max) will be applied to the terminal 510. As shown in FIG. 8, when voltage greater than the short detection voltage V_{ref1} (6.5 V) is applied to the terminal 510 due to shorting, a High signal from the Op-Amp OP1 will be output to an AND circuit AA.

[0053] As shown in FIG. 8, a short detection enable signal EN is input from the main control circuit 40 to the other input pin of the AND circuit AA. As a result, only during the time interval that a High signal is input as the short detection enable signal EN, the first detection circuit 5021 outputs the High signal from the Op-Amp OP1 as a short detection signal AB1. That is, execution of the short detection function of the first detection circuit 5021 is controlled by means of the short detection enable signal EN of the main control circuit 40. The short detection signal AB1 from the AND circuit AA is output to the main control circuit 40, as well as being output to the base pin of the transistor TR1 via resistance R1. As a result, by means of the transistor TR1 it is possible to prevent high voltage from being

applied to the power supply VDD 3.3 via the terminal 510 when a short is detected (when the short detection signal AB1 is HI).

[0054] The second detection circuit 5022 has a cartridge detection function for detecting whether there is contact between the terminal 540 and the second short detection terminal 240 of the board 200, and a short detection function for detecting shorting of the terminal 540 to the terminals 550 and 590 which output high voltage. Since the second detection circuit 5022 has the same arrangement as the first detection circuit 5021, a detailed illustration and description need not be provided here. Hereinafter, the cartridge detection signal output by the second detection circuit 5022 shall be denoted as CS2, and the short detection signal as AB2.

[0055] An arrangement of the carriage circuit 500 corresponding to a single ink cartridge 100 has been described above. In the embodiment, since four ink cartridges 100 are attached, four of the cartridge detection/short detection circuits 502 described above will be provided, at each of the attachment locations for the four ink cartridges 100. While only a single sensor driving circuit 503 is provided, and a single sensor driving circuit 503 is connectable to each of the sensors 104 of the ink cartridges 100 attached at the four attachment locations by means of a switch(not shown). The memory control circuit 501 is a single circuit responsible for processes relating to the four ink cartridges.

[0056] The main control circuit 40 is a computer of known design comprising a central processing unit (CPU), a read-only memory (ROM), and a random access

memory (RAM). As noted, the main control circuit 40 controls the entire printer; in FIG. 8, however, only those elements necessary for description of the embodiment are selectively illustrated, and the following description refers to the illustrated arrangement. The main control circuit 40 comprises a cartridge determining module M50 and a remaining ink level determining module M60. On the basis of the received cartridge detection signals CS1, CS2, the cartridge determining module M50 executes a cartridge determination process, described later. The remaining ink level determining module M60 controls the sensor driving circuit 503, and executes a remaining ink level detection process, described later.

[0057] Cartridge determination process:

The cartridge determination process executed by the cartridge determining module M50 of the main control circuit 40 will be described with reference to FIG. 9 and FIG. 10. FIG. 9 shows a flowchart depicting the processing routine of the cartridge determination process. FIGS. 10A-C show illustrations depicting three types of terminal lines on the board 200.

[0058] Before turning to the cartridge determination process, the board 200 will be described further with reference to FIG. 10. The board 200 mentioned previously comes in three types, depending on the wiring pattern of the first short detection terminal 210, the second short detection terminal 240, and the ground terminal 220. These three types are designated respectively as Type A, Type B, and Type C. As depicted in FIG. 10A, the Type A board 200 is arranged with the first short detection terminal 210 and the ground terminal 220 electrically

connected by a conducting line 207, while the second short detection terminal 240 and the ground terminal 220 are not electrically connected. As depicted in FIG. 10B, the Type B board 200 is arranged with both the first short detection terminal 210 and the second short detection terminal 240 electrically connected with the ground terminal 220 by a conducting line 207. As depicted in FIG. 10C, the Type C board 200 is arranged with the second short detection terminal 240 and the ground terminal 220 electrically connected by a conducting line 207, while the first short detection terminal 210 and the ground terminal 220 are not electrically connected. A board 200 of predetermined type, selected with reference to ink type or ink quantity for example, is disposed on the ink cartridge 100. Specifically, depending on the quantity of ink contained in the ink cartridge 100, a Type A board 200 could be disposed on an L size cartridge containing a large quantity of ink; a Type B board 200 could be disposed on an M size cartridge containing a standard quantity of ink; and a Type C board 200 could be disposed on an S size cartridge containing a small quantity of ink.

[0059] The cartridge determining module M50 of the main control circuit 40 constantly receives from the cartridge detection/short detection circuit 502 the cartridge detection signals CS1, CS2 for each of the four attachment locations of the holder 4, and using these signals executes the cartridge determination process for each of the attachment locations.

[0060] When the cartridge determining module M50 initiates the cartridge determination process for a selected attachment location, the cartridge

determining module M50 first ascertains whether the cartridge detection signal CS1 from the cartridge detection/short detection circuit 502 in the selected attachment location is a Low signal (Step S102). Next, the cartridge determining module M50 ascertains whether the cartridge detection signal CS2 in the selected attachment location is a Low signal (Step S104 or S106). If as a result the cartridge detection signals CS1 and CS2 are both Low signals (Step S102: YES and Step S104: YES), the cartridge determining module M50 decides that the ink cartridge 100 attached to the selected attachment location is furnished with the Type B board 200 (Step S108).

[0061] Similarly, the cartridge determining module M50, in the event that the cartridge detection signal CS1 is a Low signal and the cartridge detection signal CS2 is a High signal (Step S102: YES and Step S104: NO), decides that the ink cartridge is furnished with the Type A board 200 (Step S110); or in the event that the cartridge detection signal CS1 is a High signal and the cartridge detection signal CS2 is a Low signal (Step S102: NO and Step S104: YES), decides that the ink cartridge is furnished with the Type C board 200 described above (Step S112).

[0062] In the event that both the cartridge detection signals CS1 and CS2 are High signals (Step S102: NO and Step S104: NO), the cartridge determining module M50 decides that no cartridge is attached to the selected attachment location (Step S114). In this way, the cartridge determining module M50 determines whether an ink cartridge 100 is attached, and if so what type, for each of the four attachment locations.

[0063] Remaining ink level detection process:

The remaining ink level detection process executed by the remaining ink level determining module M60 of the main control circuit 40 will now be described with reference to FIG. 11 and FIGS. 12A-C. FIG. 11 shows a flowchart depicting the processing routine of the remaining ink level detection process. FIGS. 12A-C show timing charts depicting temporal change in the shorting-detection enable signal and sensor voltage during execution of the remaining ink level detection process;

[0064] The remaining ink level determining module M60 of the main control circuit 40, in the event that the remaining ink level in the ink cartridge 100 attached at any of the attachment locations of the holder 4 is to be detected, first sets to High the short detection enable signal EN to all of the cartridge detection/short detection circuits 502 (Step S202). As a result, the short detection function is enabled in all of the cartridge detection/short detection circuits 502, and if voltage above the reference voltage V_{ref1} (6.5 V) is applied to the aforementioned terminal 520 and terminal 540, are able to output High signals as the short detection signals AB1, AB2. In other words, a state in which the short detection enable signal EN are High signals is a state in which shorting of the terminal 510 or terminal 540 to the terminal 550 or terminal 590 is monitored.

[0065] Next, the remaining ink level determining module M60 instructs the sensor driving circuit 503 to output driving voltage from the terminal 550 or terminal 590 to the sensor 104, and detect the remaining ink level output (Step S204). To describe in more specific terms, when the sensor driving circuit 503

receives an instruction signal from the remaining ink level determining module M60, the sensor driving circuit 503 outputs driving voltage from either the terminal 550 or the terminal 590, the voltage being applied to the piezoelectric element which constitutes the sensor 104 of the ink cartridge 100, charging the piezoelectric element and causing it to distort by means of the inverse piezoelectric effect. The sensor driving circuit 503 subsequently drops the applied voltage, whereupon the charge built up in the piezoelectric element is discharged, causing the piezoelectric element to vibrate. In FIG. 12, the driving voltage is the voltage shown during time interval T1. As depicted in FIG. 12, the driving voltage fluctuates between the reference voltage and the maximum voltage V_s in such a way as to describe a trapezoidal shape. The maximum voltage V_s is set to relatively high voltage (e.g. about 36 V). Via the terminal 550 of the terminal 590, the sensor driving circuit 503 detects the voltage produced by the piezoelectric effect as a result of vibration of the piezoelectric element (in FIG. 12 depicted as the voltage during time interval T2), and by measuring the vibration frequency thereof detects the remaining ink level. Specifically, this vibration frequency represents the characteristic frequency of the surrounding structures (the housing 101 and ink) that vibrate together with the piezoelectric element, and changes depending on the amount of ink remaining within the ink cartridge 100, so the remaining ink level can be detected by measuring this vibration frequency. The sensor driving circuit 503 outputs the detected result to the remaining ink level determining module M60 of the main control circuit 40.

[0066] When the remaining ink level determining module M60 receives the detected result from the sensor driving circuit 503, the remaining ink level determining module M60 brings the short detection enable signal EN, which was previously set to a High signal in Step S202, back to a Low signal (Step S206), and terminates the process. In this process, the interval that the remaining ink level is being detected is a state in which the short detection enable signal EN is set to a High signal to enable short detection. In other words, remaining ink level is detected while the occurrence of shorting is being monitored by the cartridge detection/short detection circuit 502.

[0067] Process when shorting is detected

The process carried out in the event that, during execution of detection of the remaining ink level (Step S204), the remaining ink level determining module M60 receives a High signal as the short detection signal AB1 or AB2, e.g. shorting is detected shall be described here. In FIG. 11, a flowchart of the interrupt processing routine when shorting is detected is shown as well. When the terminal 510 or the terminal 540 shorts to the terminal that is outputting the sensor driving voltage of the terminals 550 and 590, the sensor driving voltage will be applied to the shorting terminal 510 or terminal 540. Thereupon, since the short detection enable signal EN is currently set to High, at the instant that the sensor driving voltage goes above the short detection voltage V_{ref1} (6.5 V), a High signal will be output as the short detection signals AB1, AB2 from the cartridge detection/short detection circuit 502. When the remaining ink level determining module M60

receives either of these short detection signals AB1, AB2, the remaining ink level determining module M60 suspends detection of remaining ink level, and executes the interrupt processing when shorting is detected.

[0068] When the interrupt processing is initiated, the remaining ink level determining module M60 immediately instructs the sensor driving circuit 503 to suspend the output of sensor driving voltage (Step S208).

[0069] Next, the remaining ink level determining module M60, without carrying out remaining ink level detection process to its conclusion, brings the short detection enable signal EN back to a Low signal (Step S206) to terminate the process. For example, the main control circuit 40 may take some countermeasure, such as notifying the user of the shorting.

[0070] FIG. 12A depicts change of the detection enable signal EN through time. FIG. 12B depicts sensor voltage in the event that neither the terminal 510 nor the terminal 540 is shorting to the terminal that outputs the sensor driving voltage of the terminals 550 and 590, so that the remaining ink level detection process is being executed normally. FIG. 12C depicts sensor voltage in the event that the terminal 510 or the terminal 540 is shorting to the terminal that, of the terminals 550 and 590, outputs the sensor driving voltage.

[0071] As depicted in FIG. 12A, during execution of the remaining ink level detection process, the detection enable signal EN is a High signal. As shown in FIG. 12B, in the normal state (no shorting), after high voltage V_s has been applied

to the sensor 104, the applied voltage drops, and subsequently vibration voltage is produced through the piezoelectric effect. In the embodiment, V_s is set at 36 V.

[0072] As depicted in FIG. 12C, on the other hand, in the abnormal state (shorting), the sensor voltage drops at the instant that it goes above the short detection voltage V_{ref1} (6.5 V). This is due to the fact that, at the instant that the sensor voltage goes above the short detection voltage V_{ref1} (6.5 V), a High signal is output as the short detection signal AB1 or AB2 from the cartridge detection/short detection circuit 502 to the remaining ink level determining module M60, and the remaining ink level determining module M60 receiving this signal immediately drops the sensor driving voltage.

[0073] FIG. 13 shows an illustration of a scenario of shorting. Here, the likely scenario for shorting to other terminals by the terminals 550 and 590 which output the sensor driving voltage is, for example, the case depicted in FIG. 13, in which an electrically conductive ink drop S1 or a water drop S2 formed by condensation has become deposited on the board 200 of the ink cartridge 100, bridging the gap between the first sensor drive terminal 250 or the second sensor drive terminal 290 and another terminal or terminals on the board 200, producing shorting. For example, ink drop S1 that has adhered to the surface of the carriage 3 or ink supply needle 6 disperses and adheres as shown in FIG. 13 by the motion of attaching or detaching of ink cartridge 100. In this instance, when the ink cartridge 100 is attached, the terminal 550 that outputs the sensor driving voltage, for example, will short to another terminal 510, 520, or 560 of the carriage circuit 500

via the first sensor drive terminal 250 and the terminals (FIG. 13: terminals 210, 220, 260) bridged by the ink drop S1 to the sensor drive terminal 250. Or, the terminal 590 that outputs the sensor driving voltage will short to another terminal 540 of the carriage circuit 500 via the second sensor drive terminal 290 and the second short detection terminal 240 (FIG. 13) bridged by the water drop S2 to the second sensor drive terminal 290, for example. Such a shorting is caused by various factor as well as the adhesion of the ink drop. For example, the shorting may be caused by trapping electrically conducting object, for example, paper clip on carriage 3. The shorting also may be caused by adhesion to terminals of the electrically conducting material, for example, skin oil of user.

[0074] As mentioned previously with reference to FIG. 3, in the ink cartridge 100 pertaining to the embodiment the first sensor drive terminal 250 and the second sensor drive terminal 290 which apply the driving voltage to the sensor are arranged at the two ends of the terminal group, so the number of adjacent terminals is small. As a result, the likelihood of the first sensor drive terminal 250 and the second sensor drive terminal 290 shorting to other terminals is low.

[0075] On the board 200, if the first sensor drive terminal 250 should short to the adjacent first short detection terminal 210, the shorting will be detected by the aforementioned cartridge detection/short detection circuit 502. For example, shorting of the first sensor drive terminal 250 to another terminal caused by the ink drop S1 infiltrating from the first sensor drive terminal 250 side will be detected instantly and the output of sensor driving voltage will be suspend, preventing or

reducing damage to the memory 203 and the printing apparatus 1000 circuits (the memory control circuit 501 and the cartridge detection/short detection circuit 502) caused by the shorting.

[0076] Also, the first short detection terminal 210 is adjacent to the first sensor drive terminal 250 and situated closest to the first sensor drive terminal 250.

Consequently, in the event that the first sensor drive terminal 250 should short to another terminal or terminals due to the ink drop S1 or the water drop S2, there is a high likelihood that the first sensor drive terminal 250 will short to the first short detection terminal 210 as well. Consequently, shorting of the first sensor drive terminal 250 to another terminal can be detected more reliably.

[0077] In addition to detecting shorting, the first short detection terminal 210 is also used by the cartridge detection/short detection circuit 502 to determine whether an ink cartridge 100 is attached, as well as to determine the type of attached ink cartridge 100. As a result, the number of terminals on the board 200 can be kept down, and it becomes possible to reduce the number of board 200 manufacturing steps and the number of parts for the board 200.

[0078] Similarly, if the second sensor drive terminal 290 should short to the second short detection terminal 240, the short will be detected by the cartridge detection/short detection circuit 502. Consequently, shorting of the second sensor drive terminal 290 to another terminal caused by the ink drop S1 or the water drop S2 infiltrating from the second sensor drive terminal 290 side can be detected instantly. As a result, damage to the circuits of the memory 203 and the printing

apparatus 1000 caused by shorting can be prevented or reduced. Similarly, the second short detection terminal 240 is the terminal situated closest to the second sensor drive terminal 290. Consequently, in the event that the second sensor drive terminal 290 should short to another terminal or terminals due to the ink drop S1 or the water drop S2, there is a high likelihood that the second sensor drive terminal 290 will short to the second short detection terminal 240 as well. Consequently, shorting of the second sensor drive terminal 290 to another terminal can be detected more reliably.

[0079] The first sensor drive terminal 250 and the first short detection terminal 210 on the one hand, and the second sensor drive terminal 290 and the second short detection terminal 240 on the other, are situated at the ends of the terminal group so that the other terminals (220, 230, 260 -270) lie between them.

Consequently, if foreign matter (the ink drop S1, water drop S2 etc.) should infiltrate from either side as indicated by the arrows in FIG. 13, this infiltration can be detected before it infiltrates as far as the other terminals (220, 230, 260 -270).

Consequently, damage to the circuits of the memory 203 and the printing apparatus 1000 due to infiltration of foreign matter can be prevented or reduced.

[0080] The first sensor drive terminal 250 and the second sensor drive terminal 290 are arranged in the row on the insertion direction R side (lower row). As a result, since the terminals 250, 290 to which sensor driving voltage including high voltage is applied are situated to the back in the insertion direction, there is less likelihood that ink drops or foreign matter (e.g. a paperclip) will infiltrate to the

location of these terminals 250, 290. As a result, damage to the circuits of the memory 203 and the printing apparatus 1000 caused by infiltration of foreign matter can be prevented or reduced.

[0081] The terminal group of the board 200 is arranged in a staggered pattern. As a result, unwanted contact of the terminals of the ink cartridge 100 with the terminals of the printing apparatus 1000 (the contact forming members 403, 404 mentioned previously) during the attachment operation can be prevented or reduced.

[0082] B. Variations:

Variations of the board 200 mounted to the ink cartridge 100 shall be described with reference to FIGS. 14A -16B. FIGS. 14A-D show first diagrams depicting boards pertaining to variations. FIGS. 15A-C show second diagrams depicting boards pertaining to variations. FIGS. 16A-B show third diagrams depicting boards pertaining to variations.

[0083] Variation 1:

On the board 200b depicted in FIG. 14A, the first short detection terminal 210 is similar to the first short detection terminal 210 of the board 200 of the embodiment, but has at its lower end an extended portion that reaches into proximity with the lower edge of the lower row. The extended portion is positioned between the first sensor drive terminal 250 and the reset terminal 260 of the lower row. As a result, for example, even in the event of adhesion of an ink drop S3 as depicted in FIG. 14 (a), shorting of the extended portion of the short detection terminal 210 to the

first sensor drive terminal 250 will be detected. Like this, when the first sensor drive terminal 250 and terminal other than the first short detection terminal 210 are shorting, there is a high possibility that the first sensor drive terminal 250 and the first short detection terminal 210 are shorting and the sensor driving voltage is suspended. Accordingly, problems caused by shorting of the first sensor drive terminal 250 to another terminal (in the example of FIG. 14A, the reset terminal 260) can be prevented or reduced.

[0084] As shown in FIG. 14A, the second short detection terminal 240 of the board 200b is also similar in shape to the first short detection terminal 210 mentioned above, and shorting of the second sensor drive terminal 290 to another terminal will also be detected more reliably.

[0085] Variation 2:

The board 200c depicted in FIG. 14B has, in addition to the arrangement of the board 200b described above, also has an extended portion located at the upper side of the first sensor drive terminal 250, and reaching into proximity with the upper edge of the upper row. As a result, even in the event of adhesion of an ink drop S4 as depicted in FIG. 14 (b), shorting of the short detection terminal 210 to the extended portion of the first sensor drive terminal 250 will be detected. Like this, when the first sensor drive terminal 250 and terminal other than the first short detection terminal 210 are shorting, there is a high possibility that the first sensor drive terminal 250 and the first short detection terminal 210 are shorting and the sensor driving voltage is suspended. Accordingly, problems caused by shorting of

the first sensor drive terminal 250 to another terminal can be prevented or reduced.

[0086] As shown in FIG. 14B, the second sensor drive terminal 290 of the board 200c is also similar in shape to the first sensor drive terminal 250 mentioned above, and infiltration of an ink drop from the end, at the end at which the second sensor drive terminal 290 is situated, can be detected instantly.

[0087] Variation 3:

The board 200d depicted in FIG. 14C differs from the board 200 of the embodiment in that there is no second short detection terminal 240. In the case of the Type A board 200 depicted in FIG. 10A, the second short detection terminal 240 does not carry out detection of contact by means of the cartridge detection/short detection circuit 502 (since there is no shorting to the ground terminal 220). Consequently, in the case of the Type A board 200, the second short detection terminal 240 is used for short detection only and accordingly can be dispensed with. In this case as well, since the first short detection terminal 210 is at the location closest to the first sensor drive terminal 250, when the first sensor drive terminal 250 and terminal other than the first short detection terminal 210 are shorting, there is a high possibility that the first sensor drive terminal 250 and the first short detection terminal 210 are shorting and the sensor driving voltage is suspended. Infiltration of an ink drop to second sensor drive terminal 290 side will also be detected to a certain extent. In FIG. 14C, the symbol CP represents the location of contact with the contact forming member 403 that would contact the

second short detection terminal 240 if the second short detection terminal 240 were present (i.e. the contact forming member 403 corresponding to the terminal 540 of the carriage circuit 500). Even in the case that the second short detection terminal 240 is absent, if a shorting should occur between the second sensor drive terminal 290 and the contact forming member 403 corresponding to the terminal 540 of the carriage circuit 500 due to an ink drop S5, infiltration of the ink drop S5 will be detected. Similarly, in the case of a Type C board 200, the first short detection terminal 210 may be dispensed with.

[0088] Variation 4:

On the board 200e depicted in FIG. 14D, the first sensor drive terminal 250 and the first short detection terminal 210 have elongated shape reaching from the vicinity of the upper edge of the upper row to the vicinity of the lower edge of the lower row. The terminals of this shape, as the contact locations are indicated by the symbol CP in FIG. 14D, can contact the corresponding contact forming portions 403 arranged in a staggered pattern. In the case of the board 200e, like the board 200c described previously, even if an ink drop S6 should become deposited for example, shorting between the extended portions of the first short detection terminal 210 and the first sensor drive terminal 250 will be detected. Like this, first short detection terminal 210 is located between first sensor drive terminal 250 and terminal other than the first short detection terminal 210. Accordingly, when the first sensor drive terminal 250 and terminal other than the first short detection terminal 210 are shorting, there is a high possibility that the first sensor

drive terminal 250 and the first short detection terminal 210 are shorting and the sensor driving voltage is suspended.

[0089] The second sensor drive terminal 290 and the second short detection terminal 240 of the board 200e have shape similar to the first sensor drive terminal 250 and the first short detection terminal 210 described above. Accordingly, when the second sensor drive terminal 290 and terminal other than the second short detection terminal 240 are shorting, there is a high possibility that the second sensor drive terminal 290 and the second short detection terminal 240 are shorting. As a result, the possibility preventing or reducing the problems caused by shorting of the sensor drive terminal 250, 290 to another terminal becomes higher.

[0090] Variation 5:

On the board 200f depicted in FIG. 15A, the terminal which corresponds to the first short detection terminal 210 and the ground terminal 220 in the board 200 pertaining to the embodiment is an integral terminal 215 wherein these two terminals are integrally formed as a single member. This board 200f can be used in place of the Type A or Type B board 200 (FIG. 10) whose first short detection terminal 210 and ground terminal 220 are shorted. With the board 200f, the need is obviated for a line between the first short detection terminal 210 and the ground terminal 220, which was required in the case of in the board 200 pertaining to the embodiment, so the board 200 requires fewer process steps and fewer parts.

[0091] Variation 6:

On the board 200g depicted in FIG. 15B, the terminals 210 -240 of the upper row each have shape similar to the first short detection terminal 210 of the board 200b described previously. Specifically, each of the terminals 210 -240 has an extended portion situated at the lower edge of the corresponding terminal of the board 200 pertaining to the embodiment and reaching into proximity with the lower edge of the lower row. The terminals 250 -290 of the lower row of the board 200g are similar in shape to the first sensor drive terminal 250 of the board 200c described earlier. Specifically, the each of the terminals 250 -290 has an extended portion situated at the upper edge of the corresponding terminal of the board 200 pertaining to the embodiment and reaching into proximity with the upper edge of the upper row.

[0092] As a result, the terminals 210 -290 of the board 200g are arranged so as to form a terminal group composed of a single row of terminals of generally oar shape of in mutually different arrangement, rather than being arranged in two rows. The first sensor drive terminal 250 and the second sensor drive terminal 290 to which the high-voltage sensor driving voltage is applied are positioned at the two ends of the single row of the terminal group, with the first short detection terminal 210 and the second short detection terminal 240 respectively arranged adjacently inward from the first sensor drive terminal 250 and the second sensor drive terminal 290.

[0093] With the board 200g, an ink drop or foreign matter infiltrating from either end can be detected immediately at the point in time that shorting occurs between

the first sensor drive terminal 250 and the short detection terminal 210, or between the second sensor drive terminal 290 and the second short detection terminal 240. In the event that the first sensor drive terminal 250 or the second sensor drive terminal 290 should short to another terminal, in the case where the shorting is due to an ink drop or the like, the likelihood is extremely high that shorting between the first sensor drive terminal 250 and the short detection terminal 210, or between the second sensor drive terminal 290 and the second short detection terminal 240, will occur at the same time. Consequently, shorting of the first sensor drive terminal 250 or the second sensor drive terminal 290 to another terminal can be detected reliably. As a result, damage to the memory 203 and the printing apparatus 1000 circuits (the memory control circuit 501 and the cartridge detection/short detection circuit 502) caused by the shorting can be prevented or minimized.

[0094] Variation 7:

On the board 200h depicted in FIG. 15C, the terminals 210 -290 have elongated shape extending over a distance equivalent to two rows of the board 200 pertaining to the embodiment, in a manner similar to the first sensor drive terminal 250 and the first short detection terminal 210 of the board 200e described previously. The terminals of this shape, as the contact locations are indicated by the symbol cp in FIG. 15C, can contact the corresponding contact forming portions 403 arranged in a staggered pattern.

[0095] In the board 200h, the terminals 210 -290 are arranged so as to form a single row in the orthogonal direction to the insertion direction R, in a manner similar to the board 200g described above. Also, like the board 200g, the first sensor drive terminal 250 and the second sensor drive terminal 290 to which the high-voltage sensor driving voltage is applied are positioned at the two ends of the single row of terminals, with the first short detection terminal 210 and the second short detection terminal 240 respectively arranged adjacently inward from the first sensor drive terminal 250 and the second sensor drive terminal 290. As a result, the board 200h affords advantages analogous to those of the board 200g described above.

[0096] Variation 8:

The first short detection terminal 210 of the board 200i depicted in FIG. 16A has a shape that is longer on the left side in the drawing, as compared to the first short detection terminal 210 of the board 200 pertaining to the embodiment. Additionally, the first short detection terminal 210 of the board 200i has an extended portion reaching from the left edge portion to the vicinity of the lower edge of the lower row. The extended portion is situated to the left of the first sensor drive terminal 250 in the lower row. In other words, the extended portion is disposed to further from the middle of the terminal group in a direction substantially orthogonal to the insertion direction R than the first sensor drive terminal 250. In this case, whereas viewed in terms of the terminal as a whole, the first short detection terminal 210 is situated outwardly (to the left side) of the first sensor drive terminal 250, when

viewed in terms of the contact portion CP of the terminal, of the contact portions CP of all of the terminals 210 -290 the contact portion CP of the first sensor drive terminal 250 is the one situated at the outermost position (left side), in the same manner as in the embodiment. Also, shorting between the first sensor drive terminal 250 and the first short detection terminal 210 that includes the contact portion CP adjacent to the contact portion CP of the first sensor drive terminal 250 is detected. Accordingly, the board 200i pertaining to this variation affords advantages similar to the board 200 pertaining to the embodiment. Specifically, infiltration of an ink drop from the edge can be detected instantly, and damage to the circuits of the memory 203 and the printing apparatus 1000 can be prevented or minimized. Additionally, since the first short detection terminal 210 has the extended portion, the length of a first portion that is a portion adjacent to the circumferential edge of the first short detection terminal 210 among the circumferential edge of the first sensor drive terminal 250 becomes long. As shown in FIG. 16B, the length of the first portion is longer than that of a second portion that is a portion adjacent to the circumferential edge of the reset terminal 260 among the among the circumferential edge of the first sensor drive terminal 250. As a result, when the first sensor drive terminal 250 and terminal other than the first short detection terminal 210, for example, the reset terminal 260 are shorting, there is a high possibility that the first sensor drive terminal 250 and the first short detection terminal 210 are shorting. Accordingly, the sensor driving voltage is

suspended and problems caused by shorting of the first sensor drive terminal 250 to another terminal can be prevented or reduced with higher probability.

[0097] The first short detection terminal 210 of the board 200p in FIG. 16C has the longer extended portion than the first short detection terminal 210 of the board 200i. As shown in FIG 16C, the extended portion of the first short detection terminal 210 of the board 200p extends from upper left to lower right of the first sensor drive terminal 250 along the circumferential edge of the first sensor drive terminal 250. As a result, the length of the first portion in the board 200p is longer than that in the board 200i. Accordingly, when the first sensor drive terminal 250 and terminal other than the first short detection terminal 210 are shorting, there is a higher possibility the sensor driving voltage is suspended and problems caused by shorting of the first sensor drive terminal 250 to another terminal can be prevented or reduced.

[0098] The first short detection terminal 210 of the board 200q in FIG. 16D has the longer extended portion than the first short detection terminal 210 of the board 200i and 200p. As shown in FIG 16D, the extended portion of the first short detection terminal 210 of the board 200q extends from upper left through lower to upper right of the first sensor drive terminal 250 along the circumferential edge of the first sensor drive terminal 250. In other words, the first short detection terminal 210 is formed so as to surround the first sensor drive terminal 250 completely. As a result, the length of the first portion in the board 200q is longer than that in the board 200i and 200p. Accordingly, when the first sensor drive terminal 250 and

terminal other than the first short detection terminal 210 are shorting, there is a higher possibility the sensor driving voltage is suspended and problems caused by shorting of the first sensor drive terminal 250 to another terminal can be prevented or reduced.

[0099] As shown in FIGS. 16A-C, board 200i, 200p, 200q are added the direction in which the portion of the first short detection terminal 210 is located adjacently to a portion of the sensor drive terminal 250 by providing the extended portion of the first short detection terminal 210. About board 200i, the extended portion of the first short detection terminal 210 located adjacently to left border of the first sensor drive terminal 250 in a lateral direction towards an edge of the ink cartridge 100, and the first short detection terminal 210 itself is located adjacently to upper border of the first sensor drive terminal 250 in opposite direction of the insertion direction R. Meanwhile, about board 200p, in addition to above-mentioned two directions, the extended portion of the first short detection terminal 210 is located adjacently to lower border of the first sensor drive terminal 250 in the insertion direction R. Furthermore, about board 200q, the extended portion of the first short detection terminal 210 is located adjacently to right border of the first sensor drive terminal 250 in lateral direction away from an edge of the ink cartridge 100. In other words, about board 200q, at least a portion of the first short detection terminal 210 is located adjacently to the first sensor drive terminal 250 in all direction.

[0100] When the first sensor drive terminal 250 and terminal other than the first short detection terminal 210 are shorting by ink drop or other object infiltrating from the direction in which the portion of the first short detection terminal 210 is located adjacently to the portion of the first sensor drive terminal 250, there is a much high possibility that the first sensor drive terminal 250 and the first short detection terminal 210 are shorting. Accordingly, problems caused by shorting of the first sensor drive terminal 250 to another terminal by ink drop or other object infiltrating from such direction can be prevented or reduced with much high probability. In the present variations, the extended portion of the first short detection terminal 210 adds the direction in which the first short detection terminal 210 and the first sensor drive terminal 250 are adjacent each other, and prevents or reduces problems caused by shorting of the first sensor drive terminal 250 to another terminal with much high probability.

[0101] In the boards 200i, 200p, 200q pertaining to this variation, only the first short detection terminal 210 on the left side is furnished with a structure having the extended portion described above, but it would be possible to furnish the second short detection terminal 240 on the right side with a structure having an extended portion, in addition to the first short detection terminal 210 or instead of the first short detection terminal 210. In this case as well, there are afforded advantages analogous to those of the boards 200i, 200p, 200q pertaining to this variation.

[0102] Variation 9:

The board 200j depicted in FIG. 16B, like the board 200f described previously in Variation 5, has an integral terminal 215 wherein the first short detection terminal 210 and the ground terminal 220 in the board 200 pertaining to the embodiment are integrally formed as a single member. The integral terminal 215 of the board 200j differs in shape from the integral terminal 215 of the board 200f described previously. Specifically, the integral terminal 215 of the board 200j, like the first short detection terminal 210 of the board 200i described in Variation 8, has a shape elongated on the left side, and has an extended portion reaching from the left edge portion to the vicinity of the lower edge of the lower row. In this case, advantages analogous to those of the board 200i pertaining to Variation 8 are attained, while reducing the number of production steps and parts needed for the board.

[0103] In the embodiment and variations described hereinabove, all of the terminals are situated on the board 200, but it is not necessary that all terminals be situated on the board 200. For example, it would be acceptable for some of the terminals to be situated on the housing 101 of the ink cartridge 100. By way of specific examples, Variation 10 and Variation 11 shall be described below with reference to FIGS. 17A -18D. FIGS. 17A-D show diagrams depicting the construction around boards of ink cartridges pertaining to variations. FIGS. 18A-D show cross sections A-A to D-D in FIG. 17.

[0104] Variation 10:

The board 200k depicted in FIG. 17A is furnished with seven terminals 210 -240 and 260 -280, out of the nine terminals 210 -290 furnished to the board 200 of the embodiment. Out of the nine terminals 210 -290 furnished to the board 200 of the embodiment, the board 200k lacks the first sensor drive terminal 250 and the second sensor drive terminal 290. The board 200k pertaining to this variation is furnished with notches NT1 or NT2 situated in zones that include the locations where the first sensor drive terminal 250 and the second sensor drive terminal 290 were disposed on the board 200 pertaining to the embodiment. The notches may have the shape indicated by the solid lines NT1, or the shape indicated by the broken lines NT2, in FIG. 17A. Terminals 150 and 190 having function similar to the first sensor drive terminal 250 and the second sensor drive terminal 290 of the board 200 in the embodiment are arranged on the housing 101 situated to the rear of the board 200k. Naturally, with the ink cartridge 100 attached to the holder 4, these terminals 150 and 190 are situated at locations contacting the corresponding apparatus-side terminals 450 and 490.

[0105] A-A cross section viewed in FIG. 17A is depicted in FIG. 18A. As shown in FIG. 18A, a depressed portion DE, formed by a gap between the notch NT1 of the board 200k and the terminal 150, is situated between the terminal 150 and the adjacent terminals 260, 210 (in FIG. 18A, the reset terminal 260 is shown). While omitted from the drawing, a similar depressed portion DE is situated between the terminal 190 and the adjacent terminals 280, 240.

[0106] According to this variation, the following advantages are afforded in addition to those analogous to the board 200 pertaining to the embodiment. If an ink drop or foreign matter should infiltrate from the end of the ink cartridge 100 pertaining to this variation, it will become trapped in the depressed portion DE arranged surrounding the terminal 150 or the terminal 190, whereby shorting of the terminal 150 or the terminal 190 to another terminal due to an infiltrating ink drop or foreign matter can be further prevented or minimized.

[0107] Variation 11:

The board 200m depicted in FIG. 17B, rather than having the notches NT1 or NT2 pertaining to Variation 10, is instead furnished with through-holes HL situated at locations corresponding to the locations where the first sensor drive terminal 250 and the second sensor drive terminal 290 are situated on the board 200 pertaining to the embodiment. B-B cross section viewed in FIG. 17B is depicted in FIG. 18B. Other arrangements of the ink cartridge 100 pertaining to Variation 11 are the same as those of the ink cartridge 100 pertaining to Variation 10. In this variation as well, depressed portions DE are situated between the terminals 150, 190 and the adjacent terminals. Accordingly, the ink cartridge 100 pertaining to this variation affords advantages analogous to those of the ink cartridge 100 pertaining to Variation 10.

[0108] Variation 12:

In the boards pertaining to the embodiment and variations, all terminals are connected to one of memory 203 and sensor 104. However, the board may

include dummy terminal that is not connected to any device. An example of such type of the board will be described as Variation 12 with reference to FIGS. 19A-D. FIGS. 19A-D show fourth diagrams depicting boards pertaining to variations.

[0109] The board 200r includes the upper row formed by four terminals and the lower row formed by five terminals, as with the board 200 pertaining to the embodiment. Arrangement and function of the terminals 210 - 290 forming the upper row and the lower row of board 200r is the same as those of the terminals of board 200 in the embodiment, so the detailed description thereof is omitted.

[0110] The board 200r shown in FIG. 19A has the dummy terminals DT between the upper row and the lower row and on the underside (the insertion direction side) of the lower row. The dummy terminals DT, for example, are made of the same material as other terminal 210-290. FIG. 19C shows E-E cross-section including dummy terminals DT. The dummy terminals DT has about the same thickness as other terminal 210-290.

[0111] The dummy terminals DT are for scraping away foreign object adherent on the contact forming members 403, for example, dust when ink cartridge 100 is attached or detached. This enables to prevent foreign object from being brought to the terminal to be contacted by contact forming member 403 (for example, the first sensor drive terminal 250 in FIG. 19C) when ink cartridge 100 is attached or detached, and to prevent contact failure between the terminal and the contact forming member 403.

[0112] The board 200r shown in FIG. 19A has the dummy terminal DT between the first sensor drive terminal 250 and the short detection terminal 210, so you can't say first sensor drive terminal 250 is located adjacent to first short detection terminal 210. However, the dummy terminals DT is not connected to memory 203 and not connected to the apparatus-side terminals 510-590 on printing apparatus 1000. Therefore, the shorting between the first sensor drive terminal 250 and the dummy terminals DT never cause any problem. Accordingly, the board 200r can afford working effects analogous to the board 200 pertaining to the embodiment. That is to say, about the board 200r, even if first sensor drive terminal 250 is not located adjacent to first short detection terminal 210 in a precise sense, at least a portion of the first short detection terminal 210 is arranged relative to at least a portion of the first sensor drive terminal 250, without a terminal connected to memory 203 (terminal 220, 230, 260-280) therebetween in at least one direction, for the detection of shorting between the first sensor drive terminal 250 and the first short detection terminal 210. In such a case, the first sensor drive terminal 250 is substantially located adjacent to first short detection terminal 210.

Consequently, in the event that the first sensor drive terminal 250 should short to another terminal or terminals due to the ink drop or the water drop, there is a high likelihood that the first sensor drive terminal 250 will short to the short detection terminal 210 as well. As a result, the output of sensor driving voltage is suspended and damage to the circuits of the memory 203 and the printing apparatus 1000 caused by shorting can be prevented or reduced.

[0113] Variation 13:

The boards pertaining to the embodiment and variations, as shown in FIG. 2, are described as the board mounted on a ink cartridge 100 used for "on carriage" type printer. However, the boards pertaining to the embodiment and variations may be mounted on an ink cartridge used for "off carriage" type printer. The ink cartridge used for "off carriage" type printer will be described below with reference to FIG. 20 and FIG.21. FIG 20 shows a perspective view of the construction of the ink cartridge pertaining to the variation 13. FIG 21 shows a picture of the ink cartridge pertaining to the variation 13 being attached to the printer.

[0114] Ink cartridge 100b pertaining to Variation 13 is configured for installation in an "off carriage" type printer, i.e., one in which the ink cartridge is not installed on a carriage. Off carriage type printers are typically large-scale printers; the ink cartridges employed in such large-scale printers are typically larger in size than the ink cartridges employed in on-carriage type printers.

[0115] Ink cartridge 100b comprises a housing 1001 containing ink, a board mounting portion 1050 for mounting board 200, an ink feed orifice 1020 for supplying ink from a housing 1001 to the printer; an air feed orifice 1030 allowing intake of air into ink cartridge 100b to allow smooth flow of ink; and guide portions 1040 for installation in the printer. The exterior dimensions of ink cartridge 100b are such that the side thereof (i.e. the depth direction) extending perpendicular to the side on which the guide portions 1040, etc. are formed (i.e. the width direction) is longer than the width direction. The relationship of the depth-wise dimension to

the width-wise dimension of board 200, expressed as a ratio of the two, is 15 : 1 or greater, for example.

[0116] As in the case of the above-mentioned embodiment, board 200 is positioned by means of boss hole 202 and boss slot 201, and secured on the board mounting portion 1050 of ink cartridge 100b.

[0117] As shown in FIG. 21, when installing the ink cartridge 100b in the printer, the guide portions 1040 of ink cartridge 100b guide the guide pins 2040 on the printer so that the board mounting portion 1050, ink feed orifice 1020, and air feed orifice 1030 are appropriately contacted/coupled with a contact pin 2050, ink feed orifice 2020, and air feed orifice 2030 on the printer. The insertion direction of ink cartridge 100b is indicated by arrow R in FIG. 21. The insertion direction R on board 200 in this variation is the same as that in the above-mentioned embodiment.

[0118] Ink cartridge 100b used for off carriage type printer pertaining to this variation can prevent or reduce problems caused by shorting of the first sensor drive terminal 250 to another terminal as in the case of the embodiment and variations described above.

[0119] Variation 14:

Configuration of the ink cartridge for "on carriage" type printer shown in FIG. 2 is one example among many. Configuration of the ink cartridge for "on carriage" type printer is not limited to this. Other configuration of the ink cartridge for "on carriage" type printer shall be described as Variation 14 with reference to FIGS. 22 -24. FIG

22 shows a first diagram of the construction of the ink cartridge pertaining to Variation 14. FIG 23 shows a second diagram of the construction of the ink cartridge pertaining to variation 14. FIG 24 shows a third diagram of the construction of the ink cartridge pertaining to Variation 14.

[0120] As shown in FIGS. 22 and 23, the ink cartridge 100b pertaining to Variation 14 includes housing 101b, board 200 and sensor 104b. On the bottom face of the housing 101b, as with ink cartridge 100 in the embodiment, there is formed an ink supply orifice 110b into which the ink supply needle inserts when ink cartridge 100b is attached to the holder 4b. The board 200 is mounted on the lower side (Z-axis plus direction side) of the front face (Y-axis plus direction side face) of the housing 101 as with ink cartridge 100 in the embodiment.

Configuration of the board 200 is identical with the board 200 in the embodiment. The sensor 104b is embedded in the side wall of the housing 101b and used for detection of remaining ink level. Hook 120b that engages with catching part of the holder 4b when the ink cartridge 100b is attached to the holder 4b is mounted on the upper side of the front face of the housing 101b. Hook 120b fixates the Ink cartridge 100b to the holder 4b. The insertion direction when the ink cartridge 100b is attached to the holder 4b is a direction of arrow R in FIG. 22 (Z-axis plus direction) as with the ink cartridge 100 in the embodiment.

[0121] The housing 101b has displacement preventers PO1 -PO4 on the side portion (x-axis direction side) of housing 101b close to the board 200. The displacement preventers PO1 -PO4 comes into contact with or close to a

corresponding portion of the side wall of the holder 4b when the ink cartridge 100b is attached to the holder 4b. This prevents the ink cartridge 100b from moving in X-axial direction from its ideal position on the holder 4b. Specifically, the displacement preventers PO1 and PO2 are located on the upper side of the board 200 and prevent the upper side of the 100b from swinging in X-axial direction taking the ink supply orifice 110b as an axis of rotation. The displacement preventers PO3 and PO4 are lateral to the terminals 210 -290 on the board 200 (FIG. 3) and keep the terminals 210 -290 in the correct position so as to contact the corresponding apparatus-side terminal 410 -490 correctly.

[0122] The electrical arrangements of the ink cartridge 100b pertaining to Variation 14 is identical with those of the ink cartridge 100 pertaining to above-embodiment described with reference to FIG. 7. So, the description thereof is omitted.

[0123] The ink cartridge 100b pertaining to Variation 14 affords the following working effects in addition to the same working effects as the ink cartridge 100 pertaining to the embodiment. Since the ink cartridge 100b has the displacement preventers PO1 -PO4, it can prevent or reduce the position displacement when the ink cartridge 100b is attached to the holder 4b. Especially, since the displacement preventers PO3 and PO4 are lateral to the terminals 210 -290 on the board 200, accuracy of positioning of the terminals 210 -290 relative to the corresponding apparatus-side terminals can be improved. Further, as described with reference to FIG. 3, in the board 200, the sensor drive terminal 250 and the second sensor

drive terminal 290 are arranged at each end of the terminals 210 -290, that is , the sensor drive terminal 250 and the second sensor drive terminal 290 are closest to the displacement preventers PO4 and PO4 respectively. This lead to improvement of accuracy of positioning of the sensor drive terminal 250 and the second sensor drive terminal 290. Therefore, the false contact between the terminals 250, 290 to which high voltage is applied and one of the non-corresponding apparatus-side terminals can be prevented or reduced.

[0124] As substitute for the board 200 in the embodiment, one of the boards 200b- 200s shown in FIGS. 14 -19 can be mounted on the ink cartridge 100b shown in FIG. 22- 24.

[0125] Other Variations:

As depicted in FIGS. 17C-D and in FIGS. 18C-D, porous elements PO may be disposed within the depressed portions DE in Variation 10 and Variation 11 described above, i.e. between the terminals 150, 190 and the board. By so doing, ink drops or condensed water, which can easily cause shorting of the terminals 150, 190 to other terminals, can be effectively absorbed by the porous elements PO. Accordingly, this design also affords advantages analogous to those of Variation 10 and Variation 11 discussed above.

[0126] In the embodiment herein, the ink cartridge 100 is furnished with a sensor 104 (piezoelectric element) and memory 203 as the plurality of the devices; however, the plurality of the devices are not limited to a sensor 104 and memory 203. For example, the sensor 104 may be a sensor of a type that detects the

properties or level of ink by means of applying voltage to the ink within an ink cartridge 100, and measuring its resistance. In the embodiment, among the plurality of the devices, the sensor 104 is mounted on the housing 101 and the memory 203 is mounted on the board 200. However, the arrangements of the plurality of the devices are not limited to those in the embodiment. For example, the memory 203 and the board 200 may be separate, and the memory 203 and the board 200 may be installed on the housing 101 individually. The plurality of the devices may be integrated into a circuit board or a single module. The circuit board or the single module may be mounted on the housing 101 or the board 200. It's preferred that terminals connected to a device to which relatively high voltage among the plurality of the devices are arranged in positions of the first sensor drive terminal 250 and the second sensor drive terminal 290 described above, and terminals connected to a device to which relatively low voltage among the plurality of the devices are arranged in positions of the terminals 220, 230, 260-280. In this case, damage to the ink cartridge 100 and the printing apparatus 1000 caused by shorting between the terminal connected to the device to which relatively high voltage and the terminal connected to the device to which relatively low voltage can be prevented or reduced.

[0127] In above-mentioned embodiment, five terminals for memory 203 (220, 230, 260-280) and two terminals for sensor 104 (250, 290) are employed, however, other number of terminals may be employed due to the specification of the device. For example, the terminal connected to the device to which relatively

high voltage may be one. In this case, such terminal may be arranged in a position of any of the terminals 250, 290 described above.

[0128] Whereas in the embodiment herein the invention is implemented in an ink cartridge 100, implementation thereof is not limited to ink cartridges, with implementation in a similar manner to receptacles containing other types of printing material, such as toner, being possible as well.

[0129] With regard to the arrangements of the main control circuit 40 and the carriage circuit 500 in the printing apparatus, portions of these arrangements implemented through hardware could instead be implemented through software, and conversely portions implemented through software could instead be implemented through hardware.

[0130] While the printing material container and board pertaining to the invention have been shown and described on the basis of the embodiment and variation, the embodiments of the invention described herein are merely intended to facilitate understanding of the invention, and implies no limitation thereof. Various modifications and improvements of the invention are possible without departing from the spirit and scope thereof as recited in the appended claims, and these will naturally be included as equivalents in the invention.

Claims

1. A printing material container detachably attachable to a printing apparatus having [a print head and](#) a plurality of apparatus-side contact forming members, the printing material container comprising:

a first device, [which is a memory](#);

a second device; and

a terminal group that includes a plurality of first terminals and at least one second terminal;

wherein:

the plurality of first terminals are connected to the first device and respectively include a first contact portion for contacting a corresponding contact forming member among the plurality of apparatus-side contact forming members,

the at least one second terminal is connected to the second device and includes a second contact portion for contacting a corresponding contact forming member among the plurality of apparatus-side contact forming members,

the printing material container further comprises a short circuit detection contact portion to contact a corresponding contact forming member among the plurality of apparatus-side contact forming members to detect shorting between the second contact portion and the short circuit detection contact portion,

[the at least one second terminal is arranged to have a higher voltage applied thereto than the plurality of first terminals,](#)

[the second device is operated by a higher voltage than the first device,](#)

the short circuit detection contact portion is located adjacent to the second contact portion,

the plurality of first contact portions, the second contact portion, and the short circuit detection contact portion are arranged so as to form multiple rows, and

the second contact portion is arranged at an end of one row among the multiple rows.

2. A printing material container according to claim 1, wherein

the second contact portion is located outermost in a row direction of the multiple rows, and

the short circuit detection contact portion is located second outermost in the row direction.

3. A printing material container according to claim 1 or claim 2, wherein
the second contact portion and a part of the plurality of first contact portions are arranged to form a first row,
the short circuit detection contact portion and another part of the plurality of first contact portions are arranged to form a second row, and
the first row is longer than the second row, and is situated further in an insertion direction in which the printing material container is detachably attached to the printing apparatus than the second row.

4. A printing material container according to claim 3, wherein the number of the first contact portions included in the first row is larger than the number of the first contact portions included in the second row.

5. A printing material container according to any one of the preceding claims, wherein:
the printing material container comprises two second terminals each having a second contact portion, and
the two second contact portions are respectively arranged at each end of one row among the multiple rows.

~~6. A printing material container according to any one of the preceding claims, wherein the first device is a memory.~~

~~76.~~ A printing material container according to ~~claim 6~~ any one of the preceding claims, wherein the plurality of first terminals consist of a ground terminal, a power supply terminal, a reset terminal, a clock terminal and a data terminal of the memory.

~~87.~~ A printing material container according to any one of the preceding claims ~~claim 6~~, wherein the first contact portions consist of contact portions of a ground terminal, a

power supply terminal, a reset terminal, a clock terminal and a data terminal of the memory.

98. A printing material container according to any one of the preceding claims, wherein the second device is a sensor for determining an amount of printing material contained in the printing material container.

~~10. — A printing material container according to any one of the preceding claims, wherein the second device is arranged to be operated by a higher voltage than the first device.~~

119. A printing material container according to any one of the preceding claims, wherein there is no terminal at the short circuit detection contact portion.

1210. A printing material container according to any one of the preceding claims, wherein:

the one row among the multiple rows is situated further in an insertion direction in which the printing material container is detachably attached to the printing apparatus than the other rows among the multiple rows.

1311. A board connectable to a printing apparatus having a print head and a plurality of apparatus-side contact forming members, the board comprising:

a first device, which is a memory; and

a terminal group that includes a plurality of first terminals and at least one second terminal;

wherein:

the plurality of first terminals are connected to the first device and respectively include a first contact portion for contacting a corresponding contact forming member among the plurality of apparatus-side contact forming members,

the at least one second terminal is connectable to a second device and includes a second contact portion for contacting a corresponding contact forming member among the plurality of apparatus-side contact forming members,

the board further comprises a short circuit detection contact portion to contact a corresponding contact forming member among the plurality of apparatus-side contact forming members to detect shorting between the second contact portion and the short circuit detection contact portion,

the at least one second terminal is arranged to have a higher voltage applied thereto than the plurality of first terminals,

the second device is operated by a higher voltage than the first device,

the short circuit detection contact portion is located adjacent to the said second contact portion,

the plurality of first contact portions, the second contact portion, and the short circuit detection contact portion are arranged so as to form multiple rows, and

the second contact portion is arranged at an end of one row among the multiple rows.

1412. A board according to claim 1311, wherein

the second contact portion is located outermost in a row direction of the multiple rows, and

the short circuit detection contact portion is located second outermost in the row direction.

1513. A board according to claim 1311 or claim 1412, wherein

the at least one second contact portion and a part of the plurality of first contact portions are arranged to form a first row,

the at least one short circuit detection contact portion and another part of the plurality of first contact portions are arranged to form a second row, and

the first row is longer than the second row, and is situated further in an insertion direction in which the printing material container is detachably attached to the printing apparatus than the second row.

1614. A board according to claim 1513, wherein the number of the first contact portions included in the first row is larger than the number of the first contact portions included in the second row.

~~17~~15. A board according to claim ~~15-13~~ or claim ~~16~~14, wherein:

the board comprises two second terminals each having a second contact portion,
and

the two second contact portions are respectively arranged at each end of the first row.

~~18~~. — A board according to any one of claims ~~13 to 17~~, wherein the first device is a memory.

~~19~~16. A board according to ~~claim 18~~any of claims ~~11 to 15~~, wherein the plurality of first terminals consist of a ground terminal, a power supply terminal, a reset terminal, a clock terminal and a data terminal of the memory.

~~20~~17. A board according to any one of claims ~~13~~11 to ~~19~~16, wherein the second device is a sensor for determining an amount of printing material contained in the printing material container.

~~21~~. — A board according to any one of claims ~~13 to 20~~, wherein the second device is arranged to be operated by a higher voltage than the first device.

~~22~~18. A board according to any one of claims ~~13~~11 to ~~21~~17, wherein there is no terminal at the short circuit detection contact portion.

~~23~~19. A printing material container comprising a board according to any one of claims ~~13~~11 to ~~22~~18.

~~24~~20. A printing system comprising:

a printing apparatus comprising a plurality of apparatus-side contact forming members; and

a printing material container according to any one of claims 1 to ~~12~~10 and ~~23~~19 detachably attached to the printing apparatus.

[2521](#). A printing system comprising:

a printing apparatus comprising a plurality of apparatus-side contact forming members; and

a board according to any one of claims [1311](#) to [22-18](#) detachably attached to the printing apparatus.

[2622](#). A printing system according to claim [24-20](#) or claim [2521](#), wherein

the apparatus-side contact forming members comprise a plurality of first contact forming members, at least one second contact forming member and at least one short circuit detection contact forming member,

the plurality of first contact forming members are in contact with first contact portions of the printing material container, whereby the first contact forming members are connected to the first device,

the at least one second contact forming member is in contact with the second contact portion, whereby the at least one second contact forming member is connected to the second device, and

the at least one short circuit detection contact forming member is in contact with the short circuit detection contact portion.

[2723](#). A printing system according to claim [2622](#), wherein

the printing apparatus further comprises an apparatus-side shorting detection circuit,

and the at least one short circuit detection contact forming member is connected to the apparatus-side shorting detection circuit to detect shorting between the second contact portion and the short circuit detection contact portion.

[2824](#). A printing material container detachably attachable to a printing apparatus having [a print head and](#) a plurality of apparatus-side contact forming members, the printing material container comprising:

a first device, [which is a memory](#);

a second device; and

a terminal group that includes a plurality of first terminals and at least one second terminal;

wherein:

the plurality of first terminals are connected to the first device and respectively include a first contact portion for contacting a corresponding contact forming member among the plurality of apparatus-side contact forming members,

the at least one second terminal is connected to the second device and includes a second contact portion for contacting a corresponding contact forming member among the plurality of apparatus-side contact forming members,

the printing material container further comprises a short circuit detection contact portion to contact a corresponding contact forming member among the plurality of apparatus-side contact forming members to detect shorting between the second contact portion and the short circuit detection contact portion,

the at least one second terminal is arranged to have a higher voltage applied thereto than the plurality of first terminals,

the second device is operated by a higher voltage than the first device,

the plurality of first contact portions, the second contact portion, and the short circuit detection contact portion are arranged so as to form two rows,

the second contact portion is arranged at a first end of a first row among the two rows, and

the short circuit detection contact portion is arranged at a first end of a second row among the two rows,

wherein the first end of the first row and the first end of the second row are located on the same side when viewed from centres of the first row and the second row, respectively.

[2925](#). A printing material container according claim [2824](#), wherein there is no terminal at the short circuit detection contact portion.

[3026](#). A printing material container according to claim [28-24](#) or claim [2925](#), wherein:
the first row is situated further in an insertion direction in which the printing material container is detachably attached to the printing apparatus than the second row.

~~31. — A printing material container according to any one of claims 28 to 30, wherein the first device is a memory.~~

~~32. — A printing material container according to any one of claims 28 to 31, wherein the second device is arranged to be operated by a higher voltage than the first device.~~

~~33~~27. A board connectable to a printing apparatus having a print head and a plurality of apparatus-side contact forming members, the board comprising:

a first device, which is a memory; and

a terminal group that includes a plurality of first terminals and at least one second terminal;

wherein:

the plurality of first terminals are connected to the first device and respectively include a first contact portion for contacting a corresponding contact forming member among the plurality of apparatus-side contact forming members,

the at least one second terminal is connectable to a second device and includes a second contact portion for contacting a corresponding contact forming member among the plurality of apparatus-side contact forming members,

the board further comprises a short circuit detection contact portion to contact a corresponding contact forming member among the plurality of apparatus-side contact forming members to detect shorting between the second contact portion and the short circuit detection contact portion,

the at least one second terminal is arranged to have a higher voltage applied thereto than the plurality of first terminals,

the second device is operated by a higher voltage than the first device,

the plurality of first contact portions, the second contact portion, and the short circuit detection contact portion are arranged so as to form two rows,

the second contact portion is arranged at a first end of a first row among the two rows, and

the short circuit detection contact portion is arranged at a first end of a second row among the two rows,

wherein the first end of the first row and the first end of the second row are located on the same side when viewed from centres of the first row and the second row, respectively.

[3428](#). A board according to claim [3327](#), wherein the board is not provided with a terminal for the short circuit detection contact portion.

[3529](#). A board according to claim [33-27](#) or claim [3428](#), wherein:
the first row is situated further in an insertion direction in which the printing material container is detachably attached to the printing apparatus than the second row.

~~36. — A board according to any one of claims 33 to 35, wherein the first device is a memory.~~

~~37. — A board according to any one of claims 33 to 36, wherein the second device is arranged to be operated by a higher voltage than the first device.~~