

# Final Report: In-situ monitoring of efficiencies of condensing boilers and use of secondary heating



**Prepared by:**

**GASTEC at CRE Ltd  
AECOM  
EA Technology**

**Prepared for:**

**The Energy Saving Trust**

**Contract Number:**

**GaC3563**

**June 2009**

## Final Report: Insitu monitoring of efficiencies of condensing boilers and use of secondary heating

### Prepared by

Name Georgina Orr  
Position Consultant GaC

Name Tom Lelyveld  
Position Principal Consultant FM

Name Simon Burton  
Position Regional Director FM

### Approved by

Name Iain Summerfield  
Position Principal Consultant and Project Manager GaC

Date: June 2009

Commercial in Confidence

GASTEC at CRE Ltd  
The Orchard Business Centre  
Stoke Orchard  
Cheltenham  
Gloucestershire  
GL52 7RZ  
Tel: +44 1242 677877  
Fax: +44 1242 676506  
E-mail: [jainsummerfield@gastecuk.com](mailto:jainsummerfield@gastecuk.com)



## Acknowledgements

The authors of this report and the project team wish to thank all those partaking in this trial for their participation and patience with the unavoidable disruption caused by the fitting of monitoring equipment in their homes and occasional visits from members of the project team through the year.

## Executive Summary

This report reviews the first complete year's data from field trials of 60 condensing boilers carried out on behalf of the Energy Saving Trust. The trials had four stated goals: to evaluate the in-situ performance and efficiency of combination (combi) and regular condensing gas boilers; to compare measured efficiencies to the SEDBUK database; to determine the amount of space heating supplied by secondary systems and to compare results to Part L requirements and BREDEM/SAP assumptions and to provide suggestions as to how BREDEM/SAP might be updated to take account of the trial results.

Almost all the boilers in the trial performed reliably over the period though due to occupant changes, occupant requests for removal from trial, and failure of monitoring or recording equipment, not all sites recorded 12 months of consecutive acceptable data. The main conclusions are based on the results from 43 boilers for which a full 12 month data set has been obtained. This trial sample included 31 combination boilers, 10 regular boilers and 2 Combined Primary Storage Unit (CPSU) boilers. Both CPSU boilers and one combination boiler were SEDBUK B rated; the remainder of the boilers in the trial were A rated.

The trial data set includes a greater number of combination than regular boilers. These field trials were run concurrent with Carbon Trust field trials of 27 regular condensing gas boilers which were monitored to allow for performance comparison with monitored micro CHP units. Data collected from both trials has a consistent format. A further addendum report will follow this, which reviews the combined data set of boilers from both trials.

The 2006 English House Condition Survey Annual Report<sup>1</sup> (EHCS) stated that in 2006 there were around 22 million households in England and Wales of which approximately 90% had central heating. In this context the data set obtained for this report is a very small sample, but the quality of the data obtained was high with a typical standard error across all boiler types of less than 1%.

## Boiler efficiency and comparison to SEDBUK

### **Combination boilers:**

The mean efficiency<sup>2</sup> of the trial set of combination boilers was 82.5% with a standard deviation of 4.0%. To ensure a like for like evaluation the mean efficiency of the trial set of combination boilers should only be compared to the mean efficiency of the trial set of regular boilers when losses from primary pipework and cylinder are included in the calculation of regular boiler efficiency.

When determining the gas demand of a combination boiler the SAP calculation includes an additional 600kWh of gas to reflect hot water purge and other losses from the boiler. These losses effectively reduce the modelled operational efficiency as compared to the SEDBUK rating. The calculation of combination boiler efficiency included these losses and so direct comparison between the combination boiler trial

<sup>1</sup> Since 2008 the English House Condition Survey is known as the EHS - English Housing Survey

<sup>2</sup> Calculated as heat out (Space Heating + domestic hot water)/gas in for 12 months of data

heat efficiency and SEDBUK rated heat efficiency is not a like for like comparison and should be avoided.

The potential to calculate an additional 'adjusted efficiency that took account of the 600kWh assumed losses to offer a more like for like comparison with the trial efficiencies of regular boilers was considered. The value of 600kWh used in SAP does not vary with property size, so any efficiency adjustments made to the trial data using a constant figure of 600kWh would have skewed the results according to heat demand, with a greater improvement in calculated trial efficiency for the homes with the smallest heat demand.

Analysis of the trial data suggests a better way forward would be to only use the SEDBUK value for seasonal efficiency for space heating demand and to separately use the standard m324 (table 2) draw off pattern for DHW to determine the efficiency of DHW supply. A small combi loss may still be appropriate but this would require further analysis. This approach would appear to be more valid than applying a blanket 600kWh combi loss and would have the further benefit of encouraging manufacturers to measure actual and improve DHW performance.

### **Regular Boilers**

The mean efficiency<sup>3</sup> of the trial set of regular boilers was 85.3% with a standard deviation of 2.5%. This is significantly less than that suggested by the mean SEDBUK seasonal efficiency of 90.4% (standard deviation 1.1%). Trial efficiencies can be directly compared to SEDBUK efficiencies, as data used to calculate efficiency was recorded at the boiler. To compare overall performance to combination boilers, performance of regular boilers should take into account losses from primary pipework and hot water cylinders. Tank and primary pipework losses were estimated from SAP at 900kWh per year. Such a loss would reduce the effective overall efficiency of the boiler by about 5% (based on an annual heat output of 15,000kWh).

Thus a more valid mean regular boiler annual efficiency may be 80.3% and a more valid comparison of regular and combination boiler annual efficiency may be 80.3% compared with 82.5%.

### **Combined Primary Storage Unit (CPSU):**

Annual heat efficiencies of CPSU boiler sites were 76.5% and 64.1% compared to a SEDBUK rated seasonal efficiency of 87.4% and 87.3% respectively. CPSU boilers include a primary thermal store and will experience cylinder losses similar to a regular boiler and associated (small) hot water cylinder.

These results suggest that an in-situ performance equivalent to the SEDBUK rated seasonal efficiency is unlikely to be observed amongst installed regular, combination or CPSU boilers in this trial sample.

## **Recommendation**

**Based on the data collected in this initial trial period we would recommend SAP incorporates a 'System correction factor' for condensing boilers of ~0.95 to improve the correlation between trial results and SAP predicted performance. For combination condensing gas boilers it is recommended SAP**

<sup>3</sup> Calculated as (all heat out of boiler)/gas in for 12 months of data

**could be amended to differentiate between DHW supply and space heating supply. Space heating supply should use a corrected SEDBUK value as suggested above and DHW should use the results of laboratory testing during DHW production alone.**

### **Domestic hot water production**

Hot water production was reviewed for summer months alone where no space heating demand was expected. This discussion of efficiency for DHW production must be treated with caution as the heat meters used were found to under record very short water draw offs (less than 15 seconds).

For summer months, the regular boilers were efficient for generating DHW to the cylinder, but recorded kWh heat delivered to taps was much lower. As little as half the energy delivered to the cylinder was recorded as drawn off for use by the householder.

Poor energy balances recorded for combination boilers in periods of very low consumption led to a laboratory investigation. This identified higher than estimated losses from ignition and fan overrun. In response to the poor performance of heat meters for short draw off patterns and the higher losses an adjustment of 25% was made (for the purpose of summer DHW assessment alone) to increase heat recorded by the heat meters to attempt to reflect the true heat used. After adjustment the combination boilers gave an estimated overall mean hot water efficiency of 73%.

The efficiency of DHW production was found to be dominated by different factors when considering regular and combination boilers. With regular boilers, efficiency is dominated by standing losses from cylinder and primary pipework and therefore very small **total** draw-off means poor efficiency. In contrast, efficiency of combination boilers is dominated by the length of individual draw-offs, thus very small **individual** draw-off (e.g. hand-washing) gives low efficiency and larger draw-offs (e.g. a bath) giving efficiencies comparable to those achieved when providing space heating. It is therefore important to choose a standard draw-off pattern when comparing the efficiency of DHW production. Currently SAP uses approximately 100 litres of DHW/day (~5.8kWh) for a 100m<sup>2</sup> property and these investigations show no substantive reason to change this.

### **Boiler load factor**

The comparison of load factor to heat efficiency indicates that heat efficiency is generally independent of load factor above a monthly load factor of approximately 5%. The majority of data recorded for load factors below 5% relates to summer, hot water led operation where there is an inevitable prevalence of poor data closure.

### **Boiler sizing**

Comparing measured heat efficiency to boiler size ratio indicates that oversizing the boiler does not, on its own, result in reduced efficiency, for either regular or combination boilers.

#### ***Regular boilers:***

It might be expected that regular boilers would be sized to the particular property using the BRE or CIBSE boiler sizing techniques. In practice no apparent correlation

was observed between installed boiler size and heat demand. This lack of correlation supports the view that choice of boiler size is based on decisions by the boiler installer and their beliefs of necessary boiler sizes, which may be independent of house size, household usage patterns and heat loss.

### **Combination boilers**

Combination boilers are normally sized on the basis of their DHW production rate; they are not sized to the heat requirement of the property. As expected no correlation was observed between installed boiler size and space heat demand.

### **Electricity use by boilers**

There is an overall trend of increasing electricity use by fans, pumps and control systems with increasing boiler use, as might be expected. Trial data indicates on average combination boilers use around 30% more electricity to supply 10,000kWh of heat than regular boilers and around 50% more electricity to supply 20,000kWh heat.

80% of boilers recorded annual electrical consumption greater than the SAP assumption of 175kWh, ranging from around 100kWh/year to over 750kWh/year. There is a wide variation in boiler electrical consumption between installations supplying similar amounts of heat.

Detailed analysis of electrical and gas consumption of boilers indicated that a key factor in electrical consumption is the pump operating hours/month which is, in turn, dependent upon the setting of the room thermostat, TRVs<sup>4</sup> and other controls. As an example, bimodal heating with accurately set room thermostat will minimise electrical consumption against continuous operation with room thermostat set to an unreasonably high value.

### **Secondary heating**

The use of secondary heating was very variable with some sites using secondary heating appliances during the summer and winter period and some sites not using secondary heating at all, even during colder months. As a generalisation households with monitored secondary heating can be divided into two categories: 25% who rarely use their secondary heating and 75% who are substantial users of secondary appliances.

Annual results from those sites returning secondary appliance data indicates that secondary heating on average accounts for approximately 4.1% of the total kWh space heating supplied to a dwelling. The highest consumption was from an electric heater situated in a conservatory, used throughout the coldest months of 2008 (in addition to a gas heater located in the lounge). If the house with heated conservatory is isolated from the dataset, then the recalculated average secondary heating accounted for only 3.6% of total space heating supplied.

Accurate analysis of overall gas use in properties with secondary heating has been difficult. This is explained by comparing the proportion of secondary heating, 3.6%, to the potential +/- 2% errors on both the boiler and fiscal meter, errors further

---

<sup>4</sup> Thermostatic radiator valves



exacerbated by the absence of temperature and reliable pressure correction of the fiscal meter.

Observations of secondary heating use is at variants with the current assumption in SAP that secondary heating accounts for 10% of the total delivered space heat for a primary gas heated home.

## **Recommendation**

**In light of results from the trials it is recommended that assumptions in Building Regulations Part L1A and SAP regarding secondary heating use should be reviewed. It is suggested that further more comprehensive monitoring of secondary and whole house energy consumption is undertaken.**

## **Conservatory heating**

14 of the 60 trial houses featured conservatories. Surveys of householders indicated that 12 of these properties featured some form of electric heating (including oil filled and convector heaters). The internal temperatures of 10 conservatories were monitored and 8 of these were associated with properties that provided 12 consecutive months of accepted data. In 6 of the 8, monthly average temperatures tracked external average temperatures whereas the internal temperatures in the other 2 conservatories tracked internal temperatures. One of these conservatories had monitored electric heating; the other either had a mobile heater or had no thermal separation from the rest of the property.

## **System Control**

A novel means of displaying the on/off firing cycle of the boilers, referred to as 'tapestry graphs', were developed by GASTEC at CRE Ltd over the trial. Tapestry graphs represent a month of data recorded at 5 minute intervals on a single page, providing immediate visualisation of the degree of modulation of the trial boilers and to the range of control settings used by householders. This gave useful insight for the follow on project concerning chrono-proportional control. Plotting of the variation between internal and external temperature versus monthly gas use, provided an indication of the how well householders manage to control gas usage. Householders whose graphs give high correlation coefficients (over 0.9) are considered well controlled; these comprise over 60% of households in the trial.

## **Internal temperatures**

Whilst SAP assumes that the living room is the warmest location in a dwelling, the trial data show that the difference between the living room, hall and upstairs temperatures is very variable. This indicates that the two zone approach used in SAP was not experienced in the trial households and this may be an area where better zoning of property could reduce energy use.

## **Limitations**

As is to be expected with any field trial there were a number of limitations on the scope and statistical significance of the trial from the instigation



- **Sample size** - Field trials recording data at 5 minute intervals and for a wide range of parameters are costly and this by nature limits the number of sites that can be included. For this trial the sample size was 60 homes which is considered a statistically small sample.
- **Self selection** – Trial properties were chosen from a pool of households with a boiler less than 2 years old who had answered a questionnaire from the Energy Saving Trust. It is possible that householders motivated to answer a questionnaire from the Energy Saving Trust may have an above average interest in energy efficiency.
- **Property size** - To be suitable for participation in the trial, properties need to have sufficient space surrounding the boiler to allow the installation of monitoring equipment. This led to the inclusion of fewer flats in the data sample than would be representative of the EHCS.
- **Geography** – For ease of maintenance and swift response to errors in monitoring equipment the majority of trial houses were located in the Midlands and North West England.

Further limitations to the data collected became understood as the trial progressed including:

- **Heat meter accuracy** – As noted above it was found that heat meters used in the trials have a significant delay in responding to changes from zero flow. In heating situations, the long periods of operation make this error negligible, but during short DHW draw offs, such as for domestic hot water, it becomes significant.
- **Calculation of secondary gas consumption** – Monitoring of secondary gas was limited by budget and space to fit bulky monitoring equipment in householder's living space. As a result, usage of secondary gas fires was measured with a thermocouple registering when fires were used. From trial data an estimate was made of the usage pattern of gas fires which combined with the fire rating estimated kWh secondary gas use. kWh data will therefore be subject to a margin of error.

## Final Report: In-situ monitoring of efficiencies of condensing boilers and use of secondary heating.

1	Glossary of Terms.....	1
2	Introduction .....	1
2.1	Objectives .....	1
2.2	Background to the trials .....	1
3	Description of Monitoring System and Installation .....	2
3.1	Description of monitoring system.....	2
3.2	Methodology for monitoring of secondary heating.....	4
3.3	Methodology for monitoring of fiscal meter readings .....	4
4	Selection of trial properties .....	6
4.1	Conservatories.....	6
4.2	Review of trial sites.....	6
4.3	Comparison with UK Building Stock .....	8
4.4	SAP assessments of trial houses .....	11
5	Field trial methodology.....	13
5.1	Data Collection .....	13
5.2	Variations in occupancy over trial period .....	13
5.3	Boiler breakdowns and house visits .....	14
5.4	Data validation and energy balance .....	14
6	Data acceptance and substitution.....	21
6.1	Review of data substitution.....	21
6.2	Combination of Energy Saving Trust and Carbon Trust trial data .....	22
6.3	Boiler efficiency and carbon benefits ratio defined .....	22
6.4	Degree day adjustment of data from Energy Saving Trust condensing boiler trials .....	23
7	Core Field Trial results and analysis.....	24
7.1	Annual monitored combustion efficiency .....	24
7.2	Comparison of trial results with SAP seasonal efficiency .....	28
7.3	Recommendations to improve the representation of the annual efficiency of combination boilers in SAP.....	33
7.4	Space and DHW heating .....	34
7.5	Annual monitored carbon benefits ratio (CBR).....	35
7.6	Monthly heat efficiency and heat demand .....	37
7.7	Annual heat efficiency and heat demand.....	38
7.8	Load factor and boiler efficiency .....	39
7.9	Boiler size and heat supplied.....	41
7.10	Analysis of boiler electrical consumption .....	42
7.11	Internal and external temperature analysis.....	46
7.12	Secondary heating.....	48
7.13	Heating patterns for central heating - modes of operation.....	58
7.14	System controls .....	65
7.15	Levels of boiler control.....	71
7.16	Whole House Fiscal usage .....	73
8	Conclusions .....	81
8.1	Boiler efficiency.....	81
8.2	Comparison of trial boiler performance with SAP .....	81
8.3	Domestic hot water production .....	82

8.4	Comparing the annual efficiency of regular boilers with DHW storage, with combination boilers.....	83
8.5	Carbon Benefits Ratio.....	83
8.6	Boiler load factor.....	83
8.7	Boiler sizing .....	83
8.8	Electricity use by boilers. ....	83
8.9	Temperature comparisons.....	84
8.10	Secondary heating.....	84
8.11	Conservatory heating.....	84
8.12	Modal operation of systems.....	85
8.13	System controls .....	85
8.14	Whole house fiscal usage.....	85
8.15	Levels of boiler control.....	85
9	Recommendations.....	86
10	Appendix A Rules For Data Substitution.....	87
11	Appendix B Combination boilers- calculation of case, purge and flue losses	89
12	Appendix C Review of Data closure of Optical readers and householder fiscal meter readings .....	90
13	Appendix D Summary of data substitution and acceptance.....	95
14	Appendix E Trial Property details .....	96

# 1 Glossary of Terms

Term	Definition
<b>BREDEM</b>	<b>Building Research Establishment Domestic Energy Model - BREDEM</b> is a model for estimating the energy consumption in dwellings for space heating, water heating, lighting and electrical appliances, and cooking. BREDEM 12 is the annual calculation methodology; BREDEM8 is the monthly calculation methodology.
<b>Boiler Parasitics</b>	Boiler parasitic use is the mains power used by the boiler for <b>internal</b> circuits, valves and pump (if pump is within the boiler).  Boiler electrical consumption includes boiler parasitic use, pump (if external to boiler) and heating system controls.
<b>CBR</b>	<b>Carbon Benefit Ratio</b> is a measure of boiler efficiency that includes the electrical use of the boiler for fan, pump and integrated control system. In order to combine the use of gas and electricity in one unit, the carbon emissions factors for gas and electricity drawn from the grid, are used in the equation.
<b>CEF</b>	<b>Carbon Emissions Factor</b> measured in KgCO <sub>2</sub> /kWh
<b>CH</b>	<b>Central Heating</b> also referred to as Space Heating (SH), combined with DHW accounts for the majority of supplied heat in a dwelling
<b>CHP</b>	<b>Combined Heat and Power</b> refers to the production of electricity and thermal energy in a single unit.
<b>CIBSE</b>	<b>Chartered Institution of Building Services Engineers</b> UK-based institution for building services including heating, ventilation and air conditioning.
<b>Combination boiler (Combi)</b>	A boiler with the capability to provide domestic hot water directly, in some cases containing an internal hot water store.
<b>Condensing boiler</b>	A boiler designed to make use of the latent heat released by the condensation of water vapour in the combustion flue products. The boiler must allow the condensate to leave the heat exchanger in liquid form by way of a condensate drain.
<b>CPSU</b>	<b>Combined Primary Storage Unit.</b> A single appliance designed to provide both space heating and domestic hot water. A burner heats a thermal store which contains mainly primary water which is common to DHW and the space heating circuit. The store must have a capacity of at least 70 litres and the feed to the space heating circuit must be taken directly from the store.
<b>DHW</b>	<b>Domestic Hot Water</b>
<b>EHCS</b>	<b>English House Condition Survey.</b> The EHCS is a national survey of housing in England, commissioned by Communities and Local Government. It covers all tenures and involves a physical inspection of property by professional surveyors. Since 2008 the ECHS is known as the EHS the English Housing Survey.
<b>EHS</b>	<b>English Housing Survey.</b> See EHCS above
<b>EU</b>	<b>European Union</b>

Term	Definition
<b>Fiscal Meter</b>	Definition used to differentiate between data recorded from monitoring equipment and data recorded from supply company meters.
<b>Fiscal Usage</b>	Fiscal gas usage is metered readings of total gas use and fiscal electricity metered readings of household electricity use.
<b>HWC</b>	<b>Hot Water Cylinder</b> – term refers to an insulated hot water tank which usually stores water under pressure, supplied with regular boilers which can not supply hot water directly.
<b>Instantaneous combination boiler</b>	A combination boiler without an internal hot water store, or with an internal hot water store of capacity less than 15 litres.
<b>Keep-hot facility</b>	A facility within an instantaneous combination boiler whereby water within the boiler may be kept hot while there is no demand. The water is kept hot either (i) solely by burning fuel, or (ii) by electricity, or (iii) both by burning fuel and by electricity, though not necessarily simultaneously.
<b>Modulating CPSU</b>	<b>Modulating Combined Primary Storage Unit</b> (see CPSU above). The appliance has the capability to vary the fuel burning rate whilst maintaining continuous burner firing.
<b>Modulating instantaneous combination boiler</b>	An instantaneous combination boiler with the capability to vary the fuel burning rate whilst maintaining continuous burner firing.
<b>Modulating regular boiler</b>	A regular boiler with the capability to vary the fuel burning rate whilst maintaining continuous burner firing.
<b>Modulating storage combination boiler</b>	A storage combination boiler with the capability to vary the fuel burning rate whilst maintaining continuous burner firing.
<b>On/off instantaneous combination boiler</b>	An instantaneous combination boiler that only has a single fuel burning rate for space heating. This includes appliances with alternative burning rates set once only at time of installation, referred to as range rating.
<b>Part L</b>	Approved Document Part L offers technical guidance for compliance with the requirements for the conservation of Fuel and Power in new and existing buildings in England and Wales. The Approved document is split into four sections: Part L1A concerns new build homes; Part L1B existing homes; Part L2A new build non domestic buildings and Part L2B existing non domestic buildings.
<b>Regular boiler</b>	A boiler which does not have the capability to provide domestic hot water directly (i.e. not a combination boiler). It may nevertheless provide domestic hot water indirectly via a separate hot water storage cylinder.
<b>SAP (2005)</b>	UK Government's <b>Standard Assessment Procedure</b> for Energy Rating of Dwellings. Based on BREDEM12, SAP 2005 is adopted by government as part of the UK national methodology for calculation of the energy performance of buildings. It is used to demonstrate compliance with building regulations for dwellings - Part L (England and Wales) and to provide energy ratings for dwellings.

Term	Definition
<b>SEDBUK</b>	<b>Seasonal efficiency of Domestic Boilers in the United Kingdom.</b> SEDBUK was developed under the Government's Energy Efficiency Best Practice Programme with the co-operation of boiler manufacturers. SEDBUK is calculated from the results of standard laboratory tests together with other important factors such as boiler type, ignition arrangement, internal store size, fuel used, and knowledge of the UK climate and typical domestic usage patterns.
<b>Storage combination boiler</b>	A combination boiler with an internal hot water store of capacity at least 15 litres but less than 70 litres, OR a combination boiler with an internal hot water store of capacity at least 70 litres, in which the feed to the space heating circuit is not taken directly from the store. If the store is at least 70 litres and the feed to the space heating circuit is taken directly from the store, treat as a CPSU.
<b>Tapestry graph</b>	Term coined by Gastec @ CRE Ltd to describe the graphical portrayal of a whole months 5 minute data on one page in small rectangles, colour coded to indicate levels of energy consumption or heat generation. See figure and explanation on page 62 for further information.
<b>TRV</b>	<b>Thermostatic Radiator Valve</b> - provides basic temperature control of an individual room by controlling flow of water into the radiator

## 2 Introduction

### 2.1 Objectives

The in-situ monitoring of efficiencies of condensing boilers and use of secondary heating trial was commissioned by the Energy Saving Trust with four principal objectives:

- To measure the in-situ combustion efficiency, under normal operating conditions, of a sample of both combination and regular condensing gas boilers in UK homes.
- To compare these measured efficiencies to the efficiencies displayed on the SEDBUK database.
- To measure the amount of space heating supplied by secondary systems, in the same sample of dwellings monitored for boiler efficiency.
- To express the use of secondary heating as a fraction of the total heat both primary and secondary heating systems are generating. These fractions will be compared to BREDEM / SAP assumptions and recommendations will be made as to whether current assumptions need updating.

Over the period of the trial further analysis was undertaken in response to monitored data. In addition to the principal objectives this report includes further analysis and findings which the authors believe may illuminate various aspects of the heating of a range of properties with gas fired condensing boilers. One key area was the in-situ combustion efficiency when providing domestic hot water only such as in summer months.

### 2.2 Background to the trials

The trial was originally conceived as two separate contracts, (A) Monitoring / Data recording and (B) Data Analysis and Reporting, but a consortium of GASTEC at CRE Ltd (GaC), AECOM (Formerly Faber Maunsell) and EA Technology was formed to provide the complete integrated project. The project was fully funded by the Department of Energy and Climate Change (DECC) and commissioned by the Energy Saving Trust.

The contract started in May 2007 and included 60 dwellings with recent combination and regular boilers, SEDBUK rated A or B. Full energy and temperature monitoring equipment was installed in each dwelling alongside the existing boiler. The methodology put forward and used was very similar to that used by the consortium on the Carbon Trust microCHP Accelerator Project, where field trials of micro CHP and boilers were on-going. This gave the advantage that results from the two trials would be perfectly compatible.

Subsequent modifications to the contract included recording of fiscal meter readings in the dwellings and a joint analysis and report which included the condensing boiler results from the Carbon Trust field trials. This combined report will be issued as a separate volume. During the project, the Energy Saving Trust decided to extend the trials using the monitoring equipment in place to monitor the performance of retrofit chrono-proportional control systems and this work is on-going at the time of this report.

This report covers the first contract using data collected from September 2007 to November 2008.



### 3 Description of Monitoring System and Installation

The 60 trial properties were monitored in terms of energy into the boiler in the form of gas and electricity and energy out of the boiler in terms of heat; both central heating (CH) and domestic hot water (DHW). These energy flows were measured using meters suitable for purpose, all of which had pulsed outputs for data logging. As well as the primary energy flows, the flue temperature of the boiler was monitored as was the external air temperature (on the north side of the property) and 3 internal temperatures; hallway, lounge and upstairs.

Where secondary heating was operational in the property this was also monitored. On gas fires, the secondary use was measured using a thermocouple in the flue. On electric appliances, the electricity consumption was metered directly. Where both electric and gas fires were operational in the property, or where there was more than one gas fire, the most frequently used appliance was monitored; usually that present in the lounge (SAP zone 1).

As well as the installed equipment each participant in the trial was asked to provide monthly fiscal meter readings for both electricity and gas. This provided data on whole house energy consumption and could be compared with both boiler operation and secondary appliances. The householder was sent a meter read form each month which they filled in and sent back to GaC.

#### 3.1 Description of monitoring system

The equipment installed in the house consisted of the following:

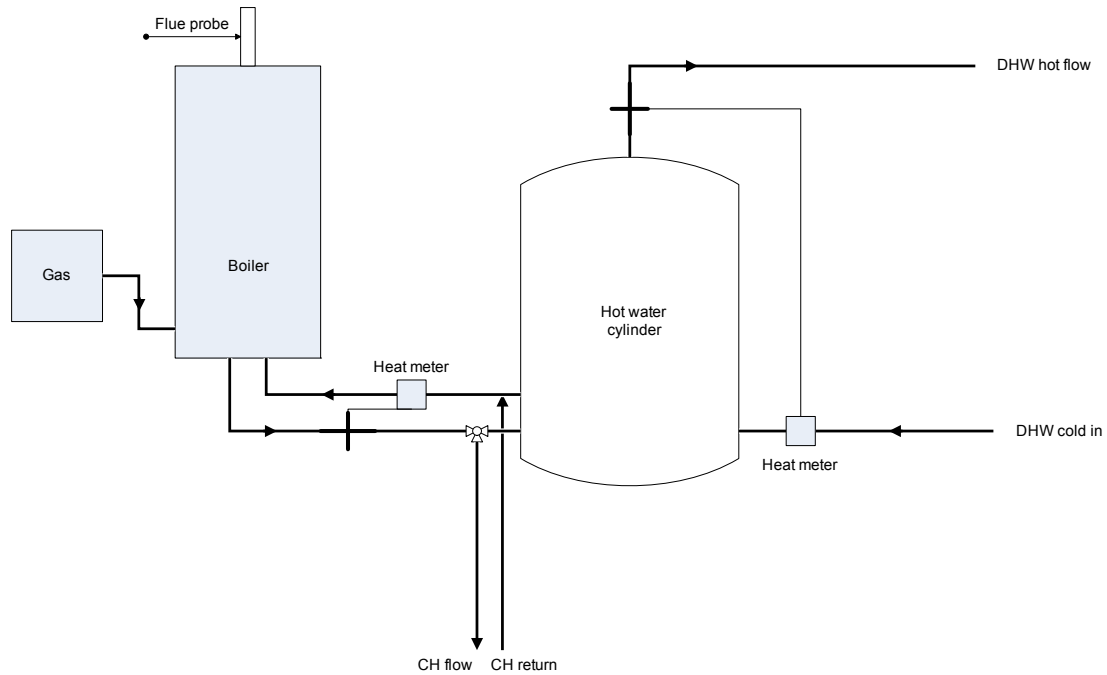
- Gas meter on gas supply to the boiler
- 2x Heat meter
  - Central Heating
  - DHW
- Electricity meter on electricity supply to the boiler
- 4x wireless temperature transmitters (5 if property included monitoring of a conservatory)
  - External ambient
  - Hallway
  - Lounge
  - Upstairs (main bedroom)
  - Conservatory
- 4x wireless transmitters collecting pulse output from the meters and measuring pipe temperatures of the flow, return and gas, and the flue temperature (5 if secondary heating included in property)
  - Heat and Gas meter
  - DHW heat meter
  - Flow, return, gas and flue temperatures
  - Boiler parasitics (electrical consumption)
  - Secondary heating (thermocouple or electricity meter)

Due to the differences in operation between a combination and a regular boiler, the meter installations were slightly different, although fundamentally measured exactly

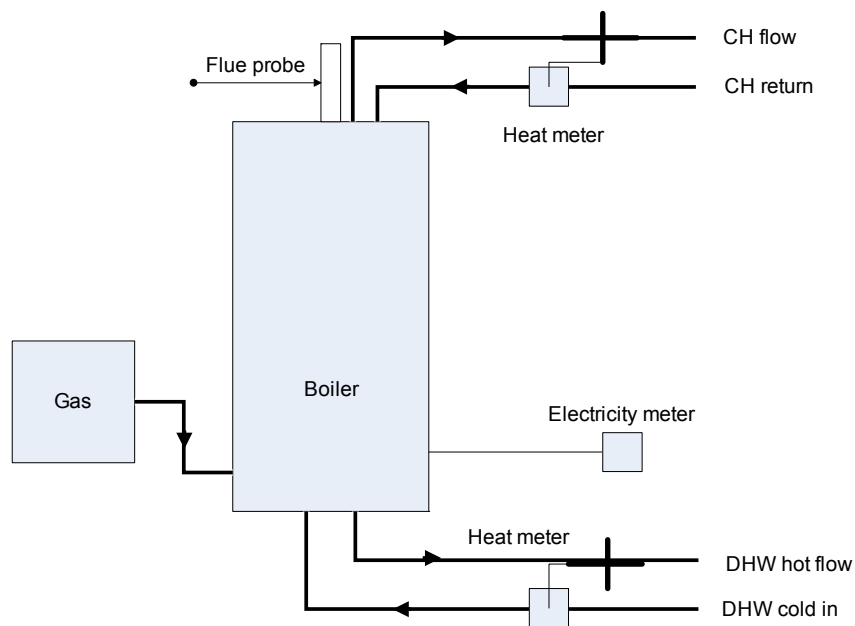
the same energy flows. On a combination boiler the space heating and domestic hot water were measured separately directly out of the boiler. With a regular boiler, total heat out of the boiler was measured (CH and DHW) and the DHW was measured separately from the cylinder. Schematics (Figure 1 and Figure 2) show the differences between combination and regular installations.

The temperature measurements were the same for each property.

*Figure 1 Schematic of monitoring points for Regular condensing boiler and HWC*



*Figure 2 Schematic of monitoring points for combination condensing boiler*



### **3.2 Methodology for monitoring of secondary heating**

Of the 60 properties, 47 had a form of secondary heating within the property. This included gas, electric and solid fuel fires. Due to the variation in fuel used in a solid fuel fire it is very difficult to accurately assess the performance of an appliance or open fire. Many people use waste material such as old timber or collect their own material for fuel. Because of this the energy into the fire is impossible to quantify accurately. Gas and electric fires offer more measurable, quantifiable fuel consumption allowing assessment of their operation.

When electric secondary heating was present within the property, the appliance was metered directly and recorded in the same way as the boiler parasitics. Here the energy was already in kWh and needed no further processing.

When a gas fire was operational within the property the actual gas consumption was impossible to measure unless a further gas meter was installed. Due to the location of the fire often being in the lounge, this option was deemed unsuitable. In some cases the fiscal gas meter could be used if no other gas was used in the property (e.g. cooking), however many people have gas cooking or two gas fires therefore this option was also unsuitable. It was concluded that the most effective way of estimating gas consumption without further intrusion to the household was to measure the flue temperature of the fire; so that if the temperature rises above 85% of the maximum flue temperature recorded for the day; the fire was assumed to be operational. This temperature data can then be processed and the kWh of gas used calculated. The data processing procedure and calculation of kWh usage is discussed later in the report.

### **3.3 Methodology for monitoring of fiscal meter readings**

Early in this condensing boiler field trial it became clear that the study could benefit from knowledge of the total secondary usage of gas and all the electricity consumed within the property. Most of the selected secondary appliances were showing very little usage.

Four routes to this information were carefully considered: The installation of a second 'primary meter' after the fiscal meter; liaison with the gas and electric supply companies for them to provide meters with pulse outputs; fitting external pulse counting data loggers to the existing meters; and request householders to regularly record meter readings.

#### **3.3.1 Installation of second primary meter**

The installation of a second 'primary meter' after the fiscal meter was rejected as being expensive and complicated. In the case of electricity it would frequently have required access to the sealed terminals of the true primary meter. In the case of gas additional metering would have resulted in problems associated with the pressure drop caused from the meter.

#### **3.3.2 Pulse meters supplied by utilities companies**

All of the suppliers to the households in the trial were approached to provide meters with pulse outputs. Replies were varied but after a number of calls and e-mails all replied that this was simply not possible. The effort to achieve this unfortunately null

result was substantial. Some required technical specifications of meters from ourselves that were then rejected, despite the meters being OFGEM approved. Some of the objections were difficult to understand, for example 'conflict with their own meter trial' or 'we cannot fit pulse output meters to domestic property'.

### 3.3.3 Householders own meter readings

Requesting householders to regularly record their meter readings was implemented on a monthly basis. However this was not a simple task as many householders wrongly record values. This was however regarded as an 'easy win' and was progressed on those properties without external pulse data loggers fitted and checking processes were put in place to minimise the impact of householder error.

### 3.3.4 External pulse data loggers

Fit external pulse generators to the existing meters; this followed successful laboratory trials and encouraging feedback from the Netherlands. Digital pulse counters collect data on a 5 minute basis and would be directly comparable with the monthly householder meter reading. The pulse counters were a strap on infra-red device that pulsed as the beam is disrupted, i.e. as the silver dot on a gas meter or the needle on an electricity meter rotates. Due to the operation of the pulse counters, only analogue meters were suitable for monitoring, therefore not all properties had counters installed. 38 of the 60 properties were monitored on at least one of the fiscal meters.

A comparison of the closure between data from pulse counters and the householders own readings is presented in Appendix C. Comparing householder readings with optical reader data has indicated that the accuracy of the pulse counters is uncertain. Optical readers fitted to gas meters were found to perform significantly worse than those fitted to electric meter. Of the 33 houses with optical readers on the gas meter, data from only 2 houses achieved reasonable closure for 4 or more of the 9 months recorded months, whereas for metered electricity 9 of 30 metered properties showed consistent 'reasonable' closure of 5-7 months. When householder gas meter readings were compared to monitored boiler gas consumption, 40 of 58 households showed reasonable closure for 5 or more of the 9 month period, supporting the relative accuracy of householder readings.

In some cases meters stopped recording due to mechanical displacement by a member of the household or the meter reader. Meters are often positioned in cupboards or garages regularly used for storage by the householder. In many cases sites have been re-visited to find the pulse counter has been dislodged by householder items (e.g. bikes or vacuum cleaners).

The failure mode of the whole house clip-on data recorders for the fiscal meters remains unknown, the units were installed by more than one individual so it was not a simple training and skills issue. Sometimes this failure was clearly due to mechanical interference by the householder or a professional meter reader, but on most occasions the readings simply diverge; this must be due to a 'malfunction' of the reader but investigations by both the contractors and the suppliers have been unable to offer any credible explanation.

The future use of these products in large scale trials cannot be recommended.

### **3.3.5 Recommendation to assist the collection of meter readings for future Energy Saving Trust. Field trials**

Future domestic field trials will require monitoring of whole house supplies, it is suggested that the EST identify suitable OFGEM approved fiscal meters (gas & electricity) and then sign a suitable protocol with senior management of all of the large energy suppliers for these to be fitted under the companies' existing rules for the replacement of broken meters. The very modest cost of such a replacement programme (which is unlikely to exceed a few hundred meters) should also be agreed.

## **4 Selection of trial properties**

Site selection began in 2006 when the Energy Saving Trust sent out approximately 2000 questionnaires to households who had shown an interest in energy use and efficiency via the Energy Saving Trust interactive website. Following this mail-shot ~220 suitable responses were received by GaC and these were further narrowed down in regards to boiler make, age and model installed in the property.

GaC visited 110 of the selected properties and confirmed 62 possible properties for inclusion. Of these, 60 final properties were chosen on the basis of the style and age of property, the type of boiler installed, and the site location within the UK.

Due to the quantity and size of the metering and monitoring equipment, the siting of the boiler was an important factor in determining whether or not a property was suitable for inclusion in the trial. Although the transmitters are fairly small, the meters are relatively large; therefore it was essential there was enough accessible pipework around the boiler in which the meters could be installed.

### **4.1 Conservatories**

Of the suitable properties, 14 had conservatories, with various secondary heating systems, including totally separate heating systems and controls. The effect of conservatories on the heat demand of a property is complex depending on whether the conservatory has closable adjoining doors to the dwelling and whether these are used. In SAP, conservatories are not included in the assessment if separated from the dwelling regardless of heating used within it. They are only included if they are directly attached to the property without adjoining doors. Thus questions are raised as to the accuracy of estimated heat or fuel required for the property. It is reasonable to suggest that properties with conservatories will lose more heat than those without. Properties in which conservatories are used during the winter months - and many are - will need considerable extra heating either from greater use of the boiler or from a form of secondary heating.

### **4.2 Review of trial sites**

The following figures show the mix of trial properties with regards to house type, age and boiler type. These are then compared with the UK building stock in section 4.3. The aim in choosing the trial sites was to select a sample that was representative of the UK housing stock in terms of age and size. Of the 60 sites, 44 properties were fitted with combination boilers and 16 with regular boilers and hot water cylinders.

Figure 3 Trial properties by type

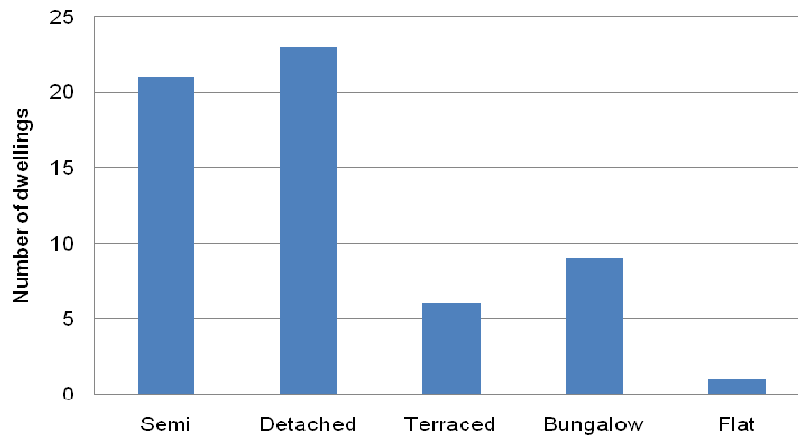


Figure 4 Trial properties by age

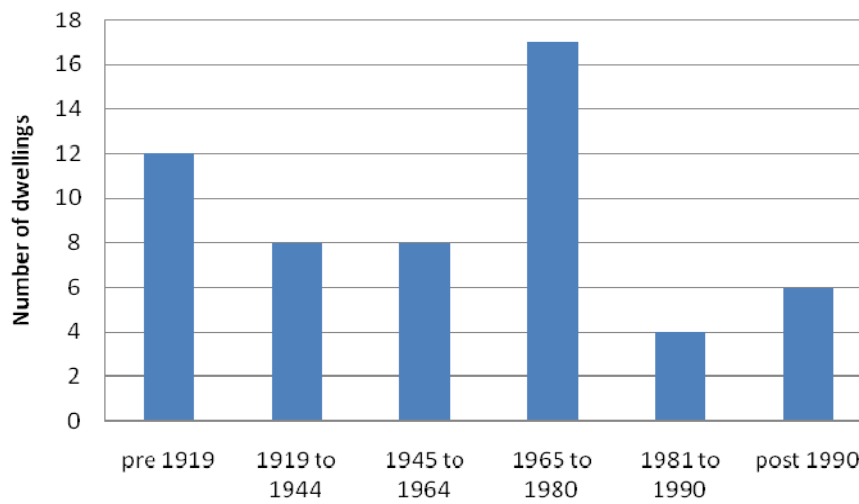
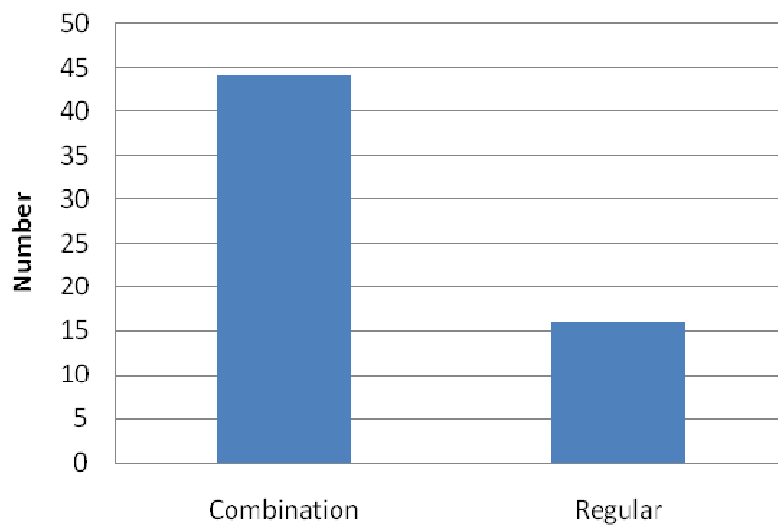


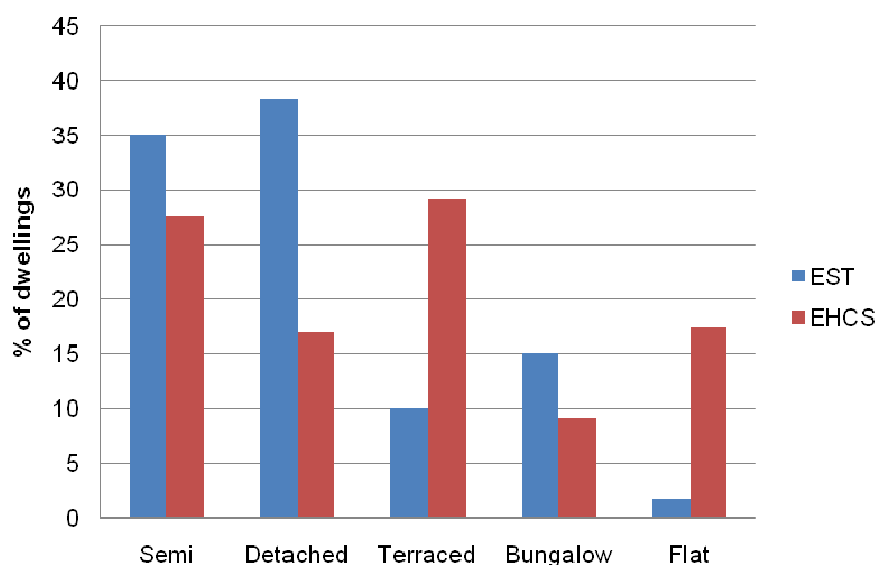
Figure 5 Boiler type installed in trial properties – regular/combination



### 4.3 Comparison with UK Building Stock

The sample of trial sites is not a random sample of the UK housing stock but was chosen from Energy Saving Trust contacts with a desire to cover a range of house heat demands, boiler sizes and types (particularly numbers of regular and combination boilers). The English House Condition Survey Report<sup>5</sup> (EHCS) contains categories of relevant information and this has been used to compare the sample of dwellings in the Energy Saving Trust trials. These can also be compared with the Carbon Trust Condensing Boiler trial sites. The following figures show comparisons between the 2006 EHCS and the Energy Saving Trust trial properties.

Figure 6 Trial sample comparison with EHCS – Dwelling type



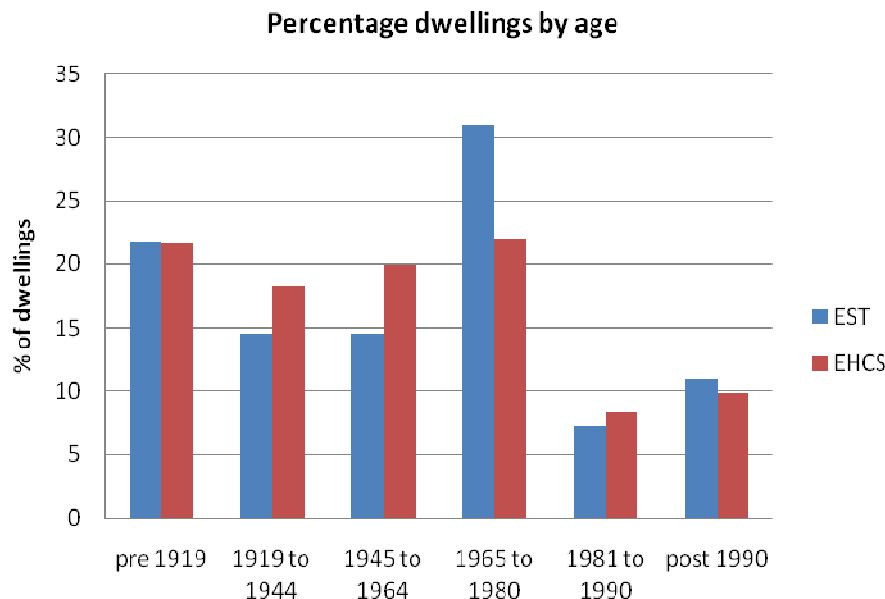
38% of the Energy Saving Trust properties are detached dwellings in comparison with only 17% suggested by the EHCS. Detached properties are usually larger than other property types and often have boilers located in garages, utility rooms or specific store rooms. This allows the metering equipment to be accommodated with greater ease and causes less visual intrusion to the resident, thus detached properties with these conditions were often favoured for installation. There may also be a slight bias due to social attitudes, terraced houses are often rented or social housing, meaning the occupants may feel they have less direct control upon the efficiency of the property than a home owner in a detached property. In rented or social housing it is also difficult for the resident to carry out any work on the property or its contents without inclusion of the council or housing association, therefore it is unlikely these residents would volunteer themselves for a trial such as this.

<sup>5</sup> Since 2008 the English House Condition Survey is known as the EHS - English Housing Survey



### 4.3.1 Property Age

The age of the trial properties compares well with the EHCS as seen in the following figure.



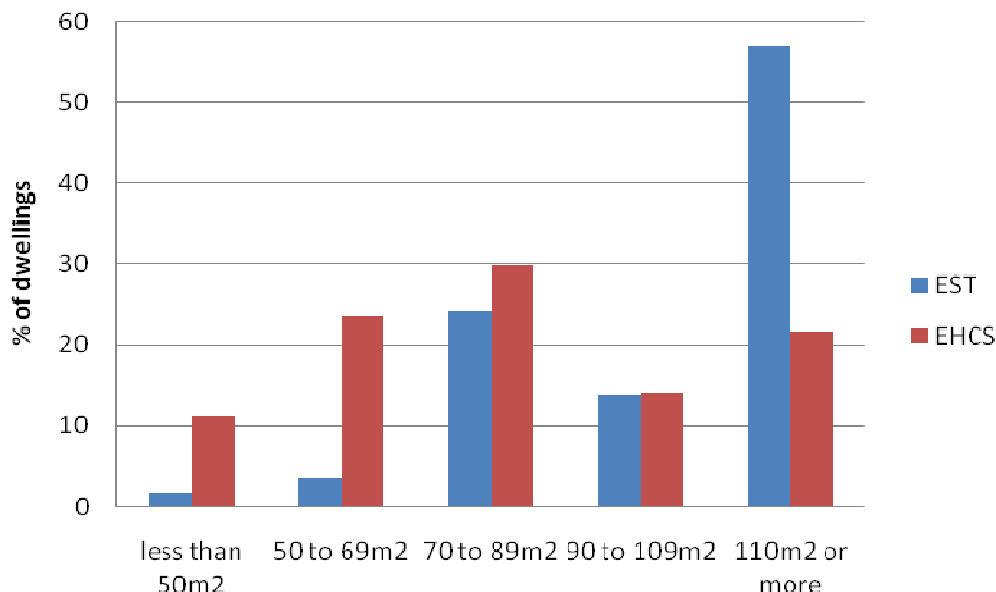
Property age can impact the performance of a boiler and heating system as older properties often have greater heat loss coefficients (HLC) than newer builds. Many older buildings are solid stone construction and may be difficult to insulate effectively, meaning they require longer or more frequent periods of boiler operation to maintain an acceptable level of comfort within the property. New builds, or properties in which insulation improvements are easy (e.g. cavity walls which can be filled or window replacements), often have much better thermal characteristics therefore lose less heat through the building fabric. Thus boilers do not operate as frequently or require much shorter burn times to heat the property to the required temperature.

The properties within this trial have been selected to include a range of property ages, from new build to almost 500 years old.

### 4.3.2 Floor Area

The comparison with floor area between the trial properties and EHCS, show the Energy Saving Trust trial has a greater percentage of larger dwellings than would be representative of the UK housing stock, this is mainly due to the number of detached dwellings being greater than terraced or semi-detached properties. The latter make up a greater proportion of the housing stock in the UK but are slightly under represented in the Energy Saving Trust trial properties, (mainly due to installation difficulties and lack of interested participants). There is also only 1 flat in the Energy Saving Trust trial compared to 17% in the EHCS. Figure 7 shows floor areas of the Energy Saving Trust trial properties and EHCS.

*Figure 7 Distribution of floor areas of Energy Saving Trust trial properties compared to EHCS*



Overall the site selection for the Energy Saving Trust trial is comparable with the UK housing stock and is a good representation of many households in the UK.

#### 4.3.3 Statistical significance of trial data set

The trial data set comprises 60 properties. Statistically this is a small sample compared to the number of UK households. The 2006 English House Condition Survey Annual Report stated that in 2006 there were around 22 million households in England and Wales of which approximately 90% had central heating.

There were a number of factors that might affect how representative the trial sample is of the UK average. Selection of the sample was not random but was limited in size by a number of factors. Trial sites were chosen from a pool of households that had returned questionnaires to the Energy Saving Trust, had a boiler less than two years old, were interested in participating and had space to install monitoring equipment.

**Self selection of energy conscious householders** - It is possible that householders motivated to answer a questionnaire from the EST may have an above average interest in energy efficiency.

**Property size - space for location on monitoring equipment** – As mentioned above, suitable properties required sufficient space surrounding the boiler to allow the installation of monitoring equipment. This has led to the inclusion of fewer flats in the data sample than would be representative of the EHCS.

**Geography** – For ease of maintenance and swift response to errors in monitoring equipment the majority of trial houses were located in the midlands and North West England.

#### 4.4 SAP assessments of trial houses

All 60 trial properties were visited by accredited Standard Assessment Procedure (SAP) assessors who surveyed the properties and provided complete SAP assessments for each dwelling.

The SAP data can be directly compared to the collected trial data in terms of heat loss co-efficient (HLC), primary heating, secondary heating and energy consumption of the properties. Figure 8 compares the HLC values taken from the SAP assessment and the calculated HLC from the trial data (heating season only).

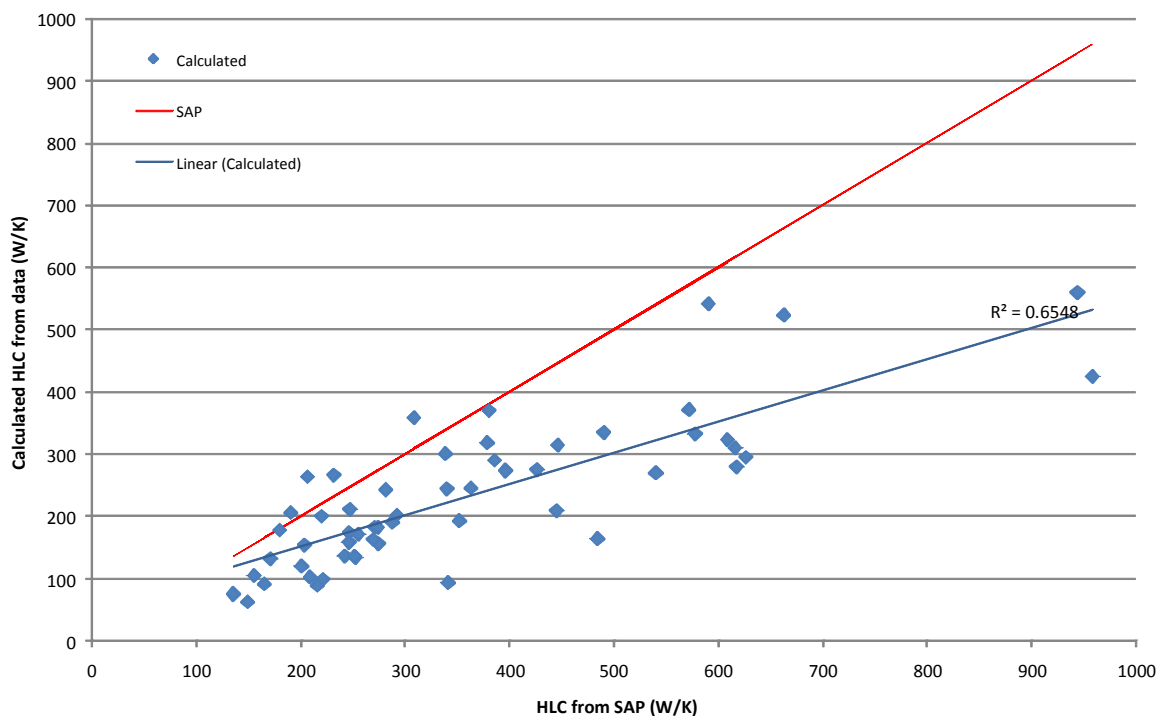
The calculation of the HLC from the site data uses the formula:  $Q=UxAx\Delta T$ .

Where Q is the sum of the measured energy inputs (gas and electricity, both primary and secondary) less the heat output in DHW, flue losses, and case losses (if boiler is not in heated envelope of the building) divided by number of seconds in a day. At a steady state (over one day), the average Q (the sum of the measured energy inputs in W/s) and the  $\Delta T$  can be calculated. The  $\Delta T$  is the difference between average inside and average outside temperatures.

UA where U is the heat transfer coefficient measured in  $W/m^2K$  and A is the area of exposed building fabric (walls, floor, roof and windows) is the Heat Loss Coefficient

THUS:  $UxA=Q/\Delta T$ .

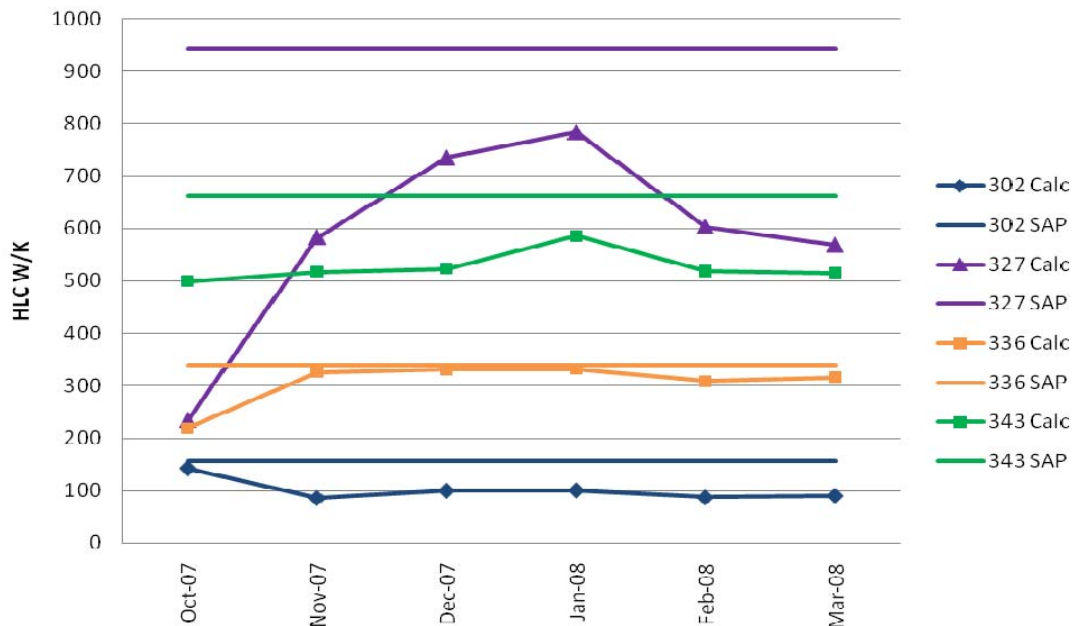
Figure 8 Comparison of SAP HLC with calculated HLC



Overall the calculated figures show little correlation to the SAP values. This supports the understanding that there are a number of factors influencing heat losses which

are not captured by the SAP survey and calculation methodology. Calculated HLC is very site dependant and relies heavily on occupancy and external factors. For example an open window will cause the calculated value to be significantly higher than the SAP value and conversely maintaining parts of the property at very low temperatures will apparently lower the calculated value. This is shown below where the SAP HLC and calculated HLC are plotted for properties 302SWI, 327BSW, 336JON and 343DNO.

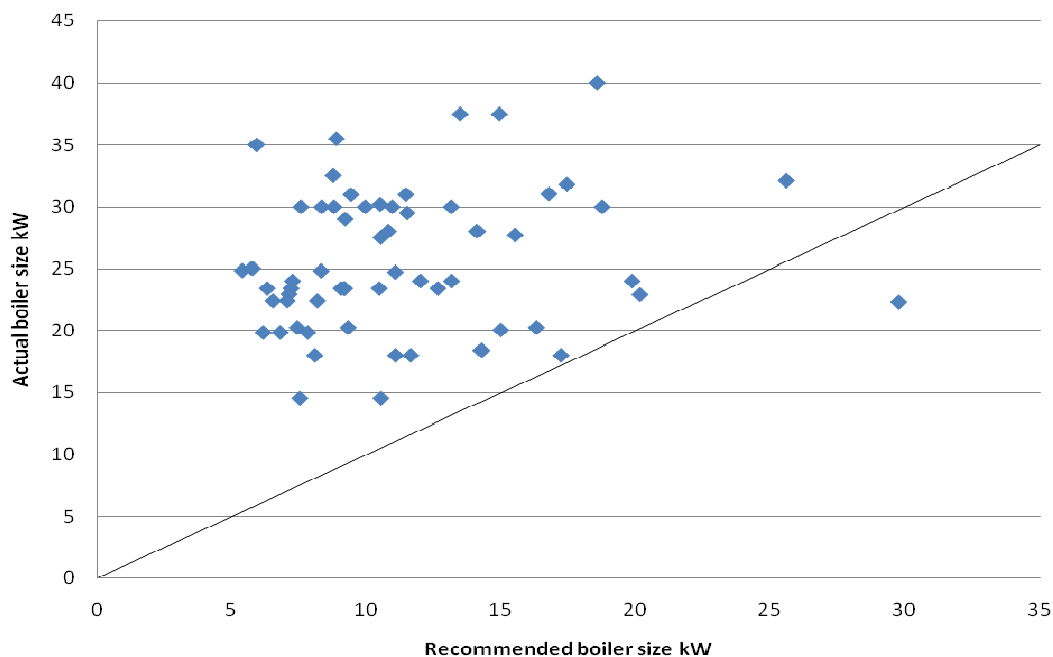
Figure 9 Sample comparison of Calculated HLC with SAP over heating period



Property 302SWI and 336JON show relatively constant U\*A values during the heating period, however in contrast properties 327BSW and 343DNO vary significantly either due to an irregular household lifestyle or only partial heating of the property. As might be expected people do not live in accordance with the SAP model.

SAP values can also be used to calculate the recommended boiler size and the actual boiler size installed in a property. In most cases the installed boiler size is considerably greater than the value suggested by SAP as shown in Figure 10 below.

Figure 10 Recommended Boiler size actual trial boiler sizes



## 5 Field trial methodology

### 5.1 Data Collection

The data were collected on a 5 minute basis from all transmitters. These data were then stored by a data logger and downloaded weekly to a central database managed by EA Technology. The data underwent an initial processing procedure and were then sent to GaC for further analysis. At GaC the data processing procedure incorporates a series of automated macros from which summaries were produced and the data analysed. These were then sent to AECOM for final analysis and reporting.

During the data collection and processing by EAT and GaC the data were checked for erroneous figures or equipment failure. As these were identified, the sites were visited or data investigated to rectify the issues. Although some poor quality data were caused by instrumentation errors, rectified as discovered, some were also caused by boiler operation and other site specific factors.

### 5.2 Variations in occupancy over trial period

Table 1 shows the properties in which problems occurred due to external factors. In most cases the sites had to be decommissioned.

*Table 1 Record of problems on site*

<b>Property Ref</b>	<b>Issue</b>	<b>Action</b>
301SPY	Resident changed mid way through trial.	Site was decommissioned when new resident moved in as the data from new tenant would not be comparable.
303AMA	Householder decided not to continue participation in trial.	Site decommissioned
328CHI	Boiler failed due to faulty component.	Heating engineer rectified problem and site continued in trial.
330LST	Many operational issues with boiler requiring frequent visits by heating engineers. Data was very poor quality.	Site was decommissioned after attempting to rectify boiler issues without success.
332HCO	Householder moved house. New tenants did not wish to continue.	Site decommissioned
348HIG	Very poor closures maintained at ~60%. Boiler operation or gas consumption incorrect. Site visited on a number of occasions investigating possible equipment failure. Boiler found to have very high CO emissions and had not been set up for LPG.	Once engineer visited site, performance improved and data became valid. Site continued in trial.
351WIL	Householder decided not to continue participation in trial.	Site decommissioned

### 5.3 Boiler breakdowns and house visits

Only two boilers (328CHI and 330LST) suffered any breakdown over the trial period although several underwent the annual service procedure. Of these two boilers 328CHI was included in the annual trial data set, the down time for boiler breakdown being comparable to an extended holiday period. 330LST did not provide 12months of accepted data and was not included in the analysis.

### 5.4 Data validation and energy balance

Data analysis was carried out on a weekly basis for all 60 properties and followed a simple processing procedure. The data were collected and checked for erroneous figures or major collection errors. Automated calculations were then carried out at two levels; the first converted the raw data into usable measurements, the second calculated an energy balance across the appliance. This used measured energy flows in and out of the appliance and calculated losses to show the proportion of energy going in compared to that coming out in the form of heat. Any equipment faults were identified and discussed between the data supplier (EATL) and GaC, then the processed data were forwarded to AECOM for the final stage of processing and substitution. An overall analysis and report was then produced for the processed data.

Figure 11 shows the monthly distribution of Gastec data validity since the trial commenced. Data validity is defined as having a closure between 93% and 103% (further discussed in section 4.4.1). Data outside of Gastec closure limits may, after review, still be accepted as valid for the purposes of analysis according to the rules of acceptance and substitution. Acceptance and substitution is reported in section 21.

As expected the validity shows an overall improvement as external temperatures decrease and more energy is used by the boiler. Similarly, the proportion of operational days shown in Figure 12 also has a marked increase during the colder winter months, with an obvious increase during September and October. Utilisation also follows this trend as can be seen in Figure 13.

Figure 11 Proportion of days data with 'valid' energy closure (93%-103%)

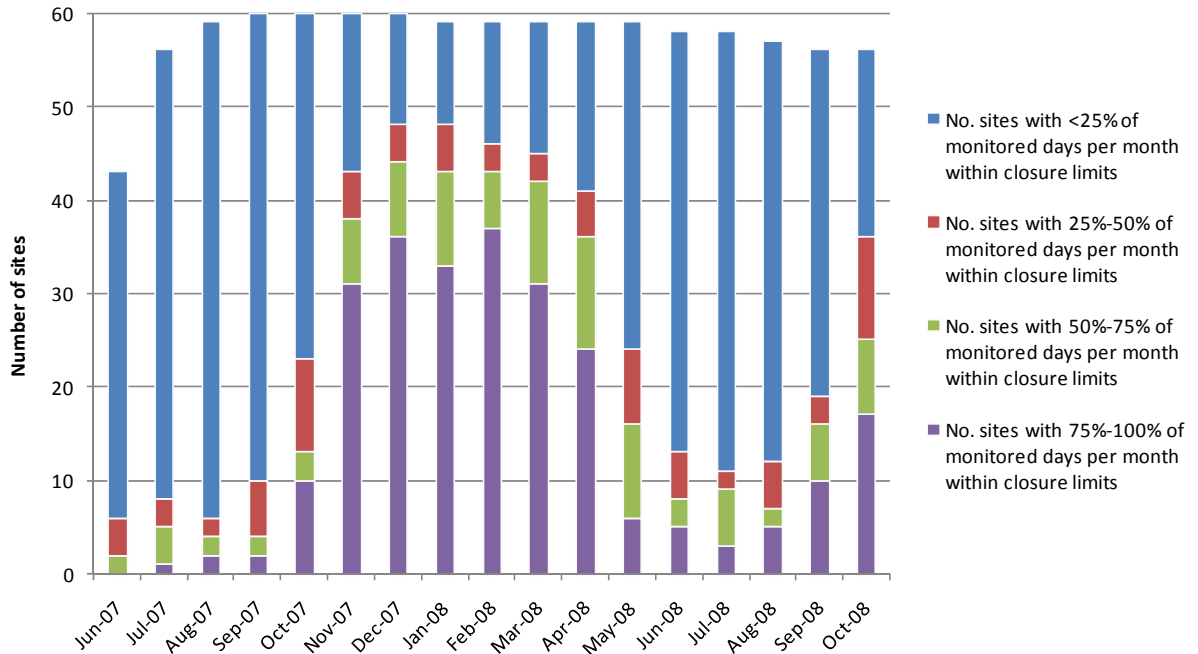


Figure 12 Proportion of operational days per site by month

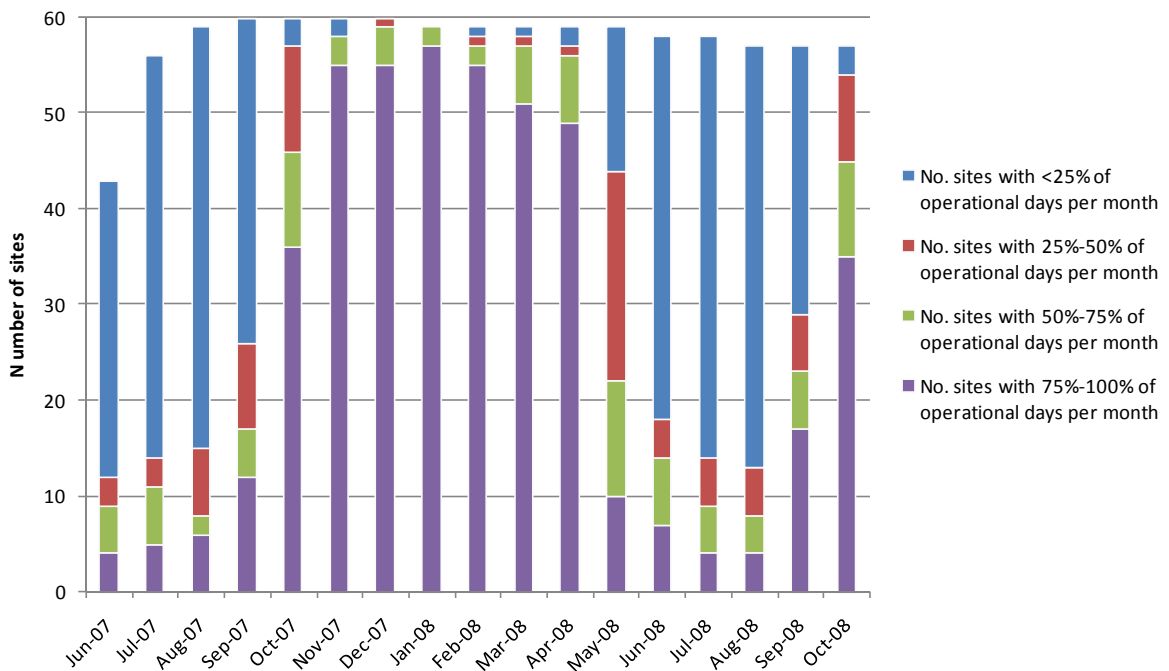
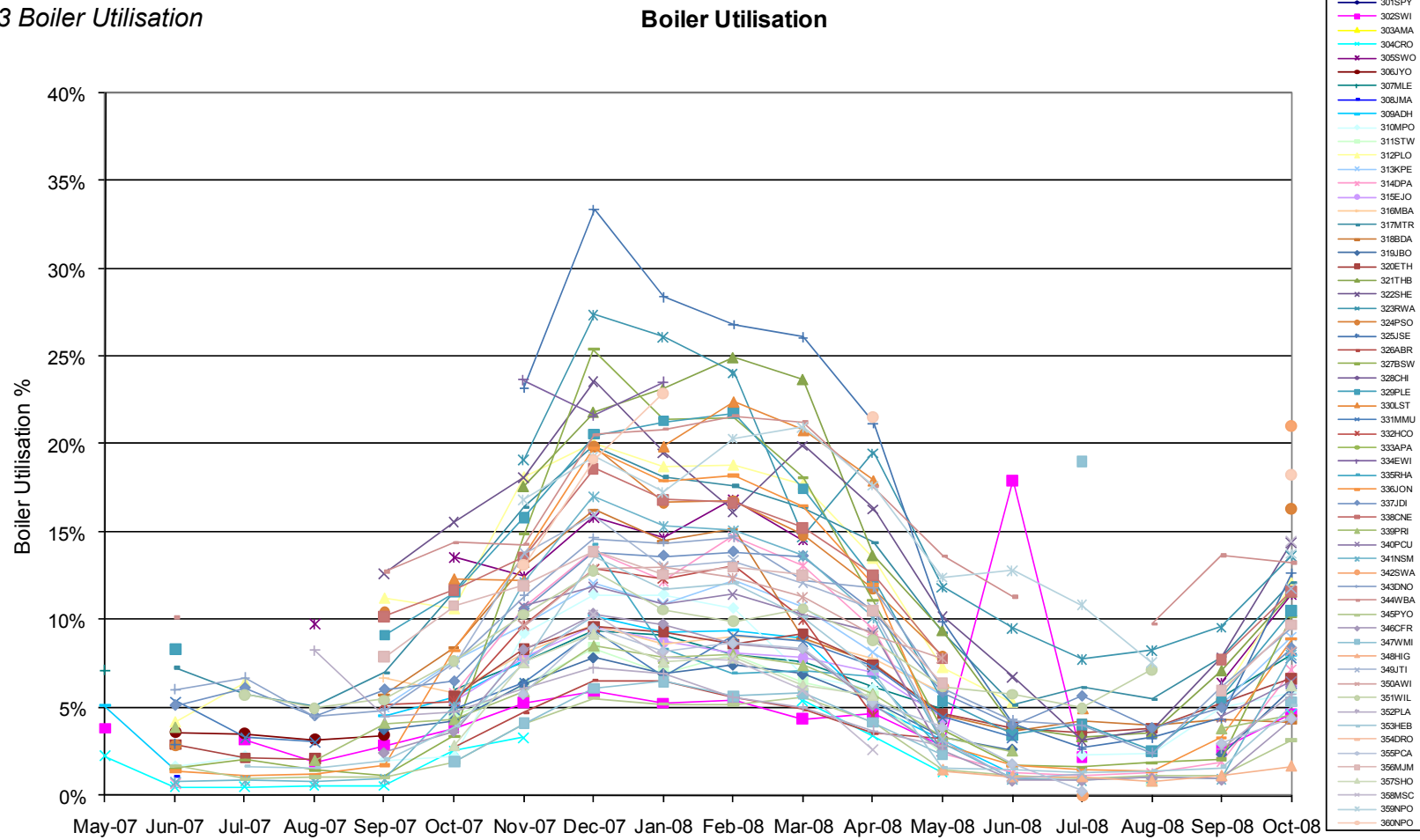




Figure 13 Boiler Utilisation



### 5.4.1 Closure Errors

It is through experience of energy monitoring that GaC are aware of the error levels when calculating energy balances. For an energy balance to be classified as valid the kW IN to the appliance must be within between 93% and 103% of the kW OUT of the appliance. It has become apparent that when operating at very low levels of utilisation, the energy balance across the appliance is likely to fall outside of this range. This is especially true when considering combination boilers. In the summer months, many combination boilers regularly only fire to produce a small amount of hot water (i.e. the householder turns the hot tap on for a matter of seconds). During this time the gas meter records gas use and the heat meter may record some heat, however due to the time interval that the transmitters operate on, the flue temperatures and sometimes the heat meter will not record any change in data. Evidence of this is discussed in a separate document<sup>6</sup>.

The result of this phenomenon means energy is recorded going in to the boiler and none recorded coming out, thus the energy balance is not complete. There are two reasons for this:

- i. The losses method formulae used by GaC have not included chemical losses in the flue gases (principally CO). In continuous operation this is extremely small but does become significant with very short firing cycles. This is discussed further in section 5.4.2.
- ii. Much of the heat produced during these very short burn times is absorbed by the boiler casing and then emitted into the room over the hour following use. Because of this, many of the sites produce poor energy balance closures during warmer summer months when the boiler is only used for hot water. Domestic hot water performance is discussed further in section 5.4.3.

To aid understanding of this, the concept of load factor has been introduced, which is the amount of gas burnt, expressed as a percentage of the possible gas burnt in a 24 hour period. Table 2 relates approximate percentage load to minutes of daily operation for a 15kW combination boiler.

*Table 2 Relationship between Load factor and operational time*

Operational time (mins)	% Load
360	25.00%
180	12.50%
90	6.25%
45	3.13%
36	2.50%
11.25	0.78%
5.6	0.39%
3.6	0.25%
1.3	0.13%

<sup>6</sup> "Investigations into the reasons why combi boilers show low heat balance closure in the EST condensing boiler trial 220953/3563, Dennish, Dec 2008."

Typically GaC have not produced a full energy balance closure on appliances operating at less than 2.5% load factor; this is about 36mins/day.

The most obvious sources of error (even if not quantitatively the largest) are likely to be:-

- incorrect estimation of start-up/shutdown loss from flue;
- incorrect estimation of start-up/shutdown loss from case;
- incorrect attribution of standby electricity.

#### 5.4.2 Incorrect estimation of start-up/shutdown loss from flue

A typical boiler has a total purge (pre- plus- post) of approximately 30 to 45 seconds. Purge loss is a function of water temperature within the boiler but this is usually known and so the calculation of purge loss should be relatively accurate. The most difficult factor is chemical loss associated with un-burnt gases, a situation exacerbated by very short cycle times. Table 3 presents the percentage energy loss likely to be associated with a typical condensing boiler purge for a variety of boiler ON times. These assume that the boiler is operating on an 80/60 circuit as might occur in DHW mode. Operation at lower water temperatures will reduce these figures.

Table 3 Percentage energy loss based on boiler purge time

Operational time per cycle (seconds)	Base efficiency %	% loss Gross
3600	85.9%	0.0%
180	84.4%	-1.5%
120	83.6%	-2.3%
60	81.8%	-4.1%
30	79.1%	-6.8%
10	74.1%	-11.8%

It can be seen that that at very short operating times, start-up/shutdown losses from the flue become substantial, hence the advantages of modulation where these losses are avoided. This energy will always be lost from the property. One of the most important features of the table is the exponential nature of the effect with decreasing ON time. Thus a boiler operating for 180 seconds will have only a ~1.5% loss associated with the purge. This will rise to ~4.1% for a 60 second ON period and 11.8% for a 10 second ON period. These values include estimates for un-burnt gases. Full details of this calculation are included in Appendix B.

#### 5.4.3 Incorrect estimation of start-up/shutdown loss from case

Losses from the case are associated with the energy required to raise the temperature of the case and water of a boiler from cold to operational temperature. Again they can be substantial for short firing periods.

Table 4 Estimation of start up/shut down losses from boiler case

Gas IN KW	Mins	Total gas kWh	Mass boiler kg	Delta T °C	Energy kWh	Water kg	Delta T °C	Energy kWh	TOTAL kWh	%loss Gross
15	360	90.000	20	30	0.13	3	40	0.14	0.26	0.29%
15	180	45.000	20	30	0.13	3	40	0.14	0.26	0.59%
15	90	22.500	20	30	0.13	3	40	0.14	0.26	1.17%
15	45	11.250	20	30	0.13	3	40	0.14	0.26	2.35%
15	22.50	5.625	20	30	0.13	3	40	0.14	0.26	4.70%
15	11.25	2.813	20	30	0.13	3	40	0.14	0.26	9.40%
15	5.63	1.406	20	30	0.13	3	40	0.14	0.26	18.80%
15	2.81	0.703	20	30	0.13	3	40	0.14	0.26	37.59%

Contrary to the flue loss, case losses are not strictly losses as the heat will be slowly released to the house after the ON period has finished. How much of this heat is transferred via the water system (i.e. is registered upon any heat meter) will be affected by pump over-run period. Also contrary to the flue loss, the colder the boiler at start-up the more heat is lost in this pre-heat process. Again one of the most important features of the table is the exponential nature of the effect with decreasing ON time. Thus a boiler operating for 90minutes will have only a ~1.17% loss associated with the pre-heat, rising to ~19% on a 5minute ON period. It **must** be stressed that unlike the purge loss, much of this may be released as useful heat **IF** the boiler is within the heated space and heat is required. Of the 60 boilers monitored in this trial, 42 boilers or 70% were located within the heated envelope of the building.

Table 5 Location of boilers in trial properties

Boiler location	Number of homes	% of total
Heated envelope	44	73%
Garage	13	22%
Loft	3	5%
Sum	60	100%

#### 5.4.4 Incorrect attribution of standby electricity

It is very difficult to be precise about the destination of the heat energy which inevitably comes from the electricity used within a boiler. To consider the electrically consuming items in detail:-

- **Pump:** A proportion (conventionally ~50%) of the electrical energy to the pump is believed to enter the water circuit as heat; the rest will emerge through the case (although if the pump is within the zone cooled by combustion air the situation is more complex).
- **Combustion fan:** If the boiler features a Forced Draft (FD) fan, the energy will predominantly go forward to the combustion chamber as air-preheat. If it is an Induced Draft (ID) fan a significant percentage of the energy will be lost to flue.

- **Electronics, gas valves etc:** This will vary from manufacturer. Some will cool these components with pre-combustion air so recovering the heat; others will locate these in separate areas where losses will be to the case.

Table 6 gives the percentage of the daily gas-input energy at three different standby consumptions for a 15kW boiler.

*Table 6 Review of boiler standby gas consumption*

Operational time mins	% Load	Standby use in Watts, 50, 25 & 10					
		50W	% 15kW	25W	% 15kW	10W	% 15kW
360	25.00%	0.90	1%	0.45	1%	0.18	0%
180	12.50%	1.05	2%	0.53	1%	0.21	0%
90	6.25%	1.13	5%	0.56	3%	0.23	1%
45	3.13%	1.16	10%	0.58	5%	0.23	2%
<b>36</b>	<b>2.50%</b>	<b>1.17</b>	<b>13%</b>	<b>0.59</b>	<b>7%</b>	<b>0.23</b>	<b>3%</b>
22.5	1.56%	1.18	21%	0.59	11%	0.24	4%
11.25	0.78%	1.19	42%	0.60	21%	0.24	8%
5.63	0.39%	1.20	85%	0.60	42%	0.24	17%
2.81	0.20%	1.20	170%	0.60	85%	0.24	34%
1.41	0.10%	1.20	340%	0.60	170%	0.24	68%

It can be seen that at the 2.5% load factor in ONE period the un-attributable heat is probably in the range 3 to 13%. Unlike the previous factors, if the firing period is split into TWO there is no impact upon this value. In practice the true standby loss of most boilers is substantially less than 15W i.e. electrical input is less than ~6% of gas usage.

Due to these areas of loss it can be concluded that down to a load factor of ~2.5% (~36minutes/day) any efficiency results are dominated by the gas burn. Below this figure the results become exponentially dependant upon appliance and system details. For example, for a domestic water draw off of 6kWh a day (equivalent to a 1.67% load on a 15kW boiler) the level of complication introduced by the above factors will be between approximately 10% and 20% as shown below in Table 7.

*Table 7 Calculated percentage loss for a 6kWh/day draw off*

Purge	1.5 to 11.9%	Depending upon length of draws
Heat up	~4%	
Standby 10W	~5%	
Sum	~10.5 to 20.9%	

It is therefore to be expected that any appliance producing DHW only would produce energy closures in the range 80% to 90% and easily lower if the pattern of use is a series of hand-wash type draw-offs. This indicates that care must be taken not to over-analyse any particular set of results, nor to always seek explanations for poor energy balance closure in terms of incorrect/faulty equipment operation.

## 6 Data acceptance and substitution

The data acceptance and substitution process aims to ensure that poor quality data or inaccurate data points are excluded whilst maximising the number of full 12 month datasets available for analysis. Some substitution is almost always necessary with field trial data, for a number of reasons:-

- Sensors may fail to give some readings or the signal may not reach the logger.
- Data loggers may not transmit data at a regular interval, but may do so in lumps.
- After a long off period, equipment may not immediately start working correctly, particularly heat meters.
- Monitoring equipment does sometimes fail and need replacing; data substitution can be used to make up a full data set to enable the site to contribute to the overall results.
- Equipment can go out of calibration.

Raw data should never be used directly for analysis, as including data that are obviously wrong can significantly distort results. Substitution aims to eliminate errors in data that distort findings and produce full and reasonable data sets which will give accurate results. Substitution has been kept to a minimum accounting for 1.4% of total days of data. The effects of substitution on a full data set for a site will be very small, and this effect will be even smaller on the whole project.

Data are substituted only where there is clear failure of monitoring equipment and normally complete days of data are substituted, not individual numbers.

### 6.1 Review of data substitution

Monitoring commenced in May/June 2007 with the data analyst receiving sets of monitored data from 43 of the total 60 trial sites from June 2007 with data from the remaining 17 boilers being received from August 2007. At the time of reporting, up to 17 months of data have been received from individual trial boilers and monitoring for longer than a set 12 month period has improved the number of complete 12 month data sets.

To compare the trial findings with SEDBUK ratings (laboratory rated seasonal efficiency) an uninterrupted 12 months of data was required to calculate annual efficiency. Of the full trial set of 60 boilers, 43 have provided annual datasets that, after data substitution present 12 consecutive complete months of data. This data set includes 31 combination boilers, 10 regular boilers with hot water cylinders and 2 CPSU boilers.

Table 8 below summarises, to the end of October 2008, the number of months of data accepted, the number months of data not accepted; the number of days of data substituted and the number of boilers affected across the trial. Details of individual sites are presented in Appendix D.

In summary, of the full year data sets assessed in this report comprising 15,695 days of data, 225 days (2.3%) of data have been substituted across 25 of the 43 boilers over the months of June 07 to October 08.



*Table 8 Summary of trial data substitution and acceptance*

12 month Data sets	Jun07-Oct08	Percentage
Complete 12-month sets	43	72% of 60 sites
No. months of complete data in 12 month data sets	516	
Months accepted in 12 month data set with no substitution	449	87% of 516
Months accepted in 12 month data set with some substitution	67	13% of 516
Number of substituted days in 12 month data sets used	225	1.4% of (43 x 365) days

## 6.2 Combination of Energy Saving Trust and Carbon Trust trial data

The Energy Saving Trust field trials were run concurrent with the later stages of field trials of micro CHP units commissioned by the Carbon Trust. Part of the Carbon Trust trials included the monitoring of 27 regular condensing gas boilers for comparison with the micro CHP units. 24 of the 27 monitored boilers returned complete 12 month data sets. Data collected from both trials have a consistent format. A further addendum report will follow this which reviews the combined data set of boilers from both trials

## 6.3 Boiler efficiency and carbon benefits ratio defined

In the analysis of the monthly and annual results two principle performance factors are used: the simple efficiency and the Carbon Benefits Ratio (CBR).

The simple “efficiency” of the boilers is calculated from heat out divided by the energy of the gas used (based on the higher calorific value) as a percentage. The “simple efficiency (also referred to as the ‘heat efficiency’) is defined as:

$$\text{Heat Efficiency (\%)} = \frac{\text{useful heat delivered (space+hot water) [kWh]} \times 100}{\text{Gas burnt [kWh]}}$$

The SEDBUK database uses this definition of efficiency and where comparison is made between trial efficiency and SEDBUK values, the simple efficiency is used.

The CBR is a similar measure of efficiency **but includes the electrical use of the boiler** for fan, pump and integrated control system. In order to combine the use of gas and electricity in one unit, the carbon emissions factor (CEF) for gas (or any other fuel), and electricity drawn from the grid, are used in the equation. The CBR is defined as:

$$\text{CBR (\%)} = \frac{(\text{useful heat delivered [kWh]} \times \text{CEF}_{\text{gas}} [\text{kgCO}_2/\text{kWh}]) \times 100}{(\text{gas burnt [kWh]} \times \text{CEF}_{\text{gas}} [\text{kgCO}_2/\text{kWh}] + (\text{electricity used [kWh]} \times \text{CEF}_{\text{electricity}} [\text{kgCO}_2/\text{kWh}])}$$

The CBR has the additional advantage that it can be used to compare efficiency of boilers with microCHP, where the CBR is similarly defined but includes the electricity



generated on the top line together with the heat output. CBR can also be used to compare performance with that of heat pumps.

The CEF for gas is currently taken as 0.194 kg/kWh and for electricity as 0.568kg/kWh. These values can be changed as required by the EST.

#### **6.4 Degree day adjustment of data from Energy Saving Trust condensing boiler trials**

Degree day adjustments can be made to gas used and space heating supplied to standardise the annual performance of the boilers. Most of the data analysis in this report relates to efficiencies of the boiler operation for different levels of output and degree day adjustment is not relevant to this. Although there is an increase in efficiency with increasing monthly and annual gas use, degree day adjustment would have a marginal effect on the graphs and not provide better information.

The main use of degree day adjustment is to estimate typical annual heat demands and hence gas use or energy savings from changes and this analysis is not part of the project. Hence no degree day adjustment has been carried out.

## 7 Core Field Trial results and analysis

### 7.1 Annual monitored combustion efficiency

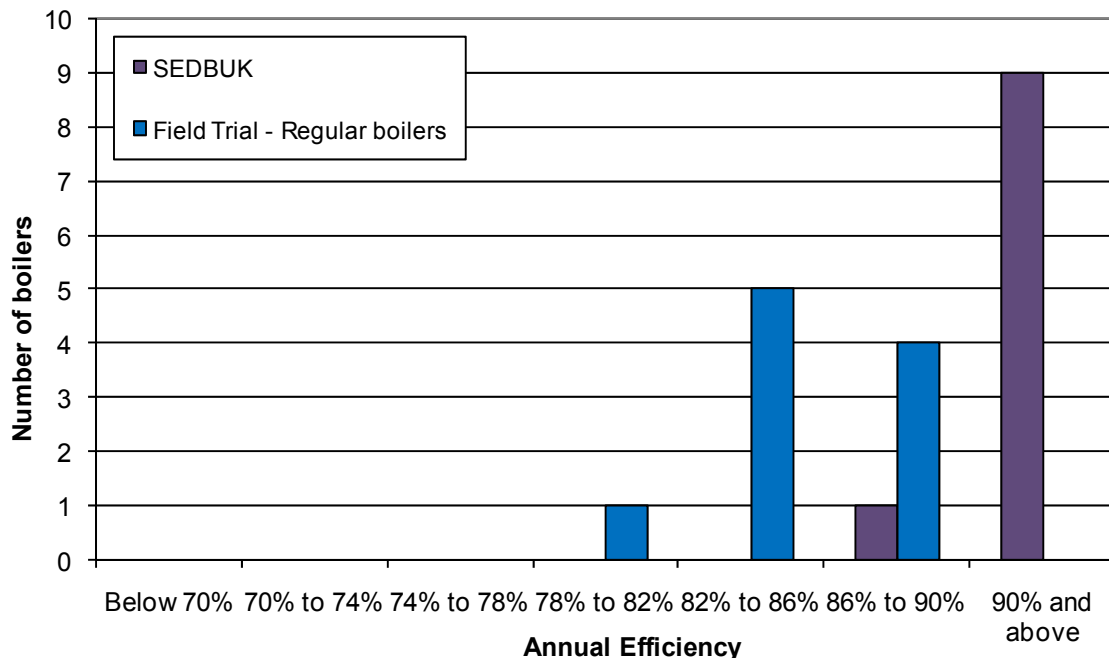
Table 9, Table 10 and Table 11 present the annual heat efficiencies of those boilers that have returned a complete 12 month set of recorded data. All boilers have measured seasonal heat efficiencies that are lower than their SEDBUK rated equivalent. This is not unexpected in comparing field trial results with manufacturer's laboratory test conditions.

#### 7.1.1 Regular boilers efficiency

Annual heat efficiencies for the ten individual sites with regular boilers are distributed between 89.2% and 81.2%. The mean efficiency of the sample set of regular boilers was 85.3% with a standard deviation of 2.5%. The mean of the SEDBUK rated seasonal efficiencies of the regular boilers was 90.4% with a standard deviation of 1.1%. The mean of the trial data suggests that the in situ performance of the boilers is significantly less than the rated SEDBUK seasonal efficiency. Efficiency for the regular boilers was calculated from total heat out measured at the boiler divided by boiler gas consumption. As such, the calculated efficiency does not include losses from primary pipework or hot water cylinder and can be directly compared to the SEDBUK rated seasonal efficiency. DHW draw off from the cylinder was measured separately but this was not used in the calculation of heat efficiency.

It is suggested that to allow SAP to better reflect the performance of regular boilers in modelled performance an 'in use' performance factor of 0.95 be applied to the SEDBUK rated seasonal efficiency to reflect observed performance

Figure 14 Comparison of field trial annual regular condensing gas boiler performance to SEDBUK rated seasonal efficiencies



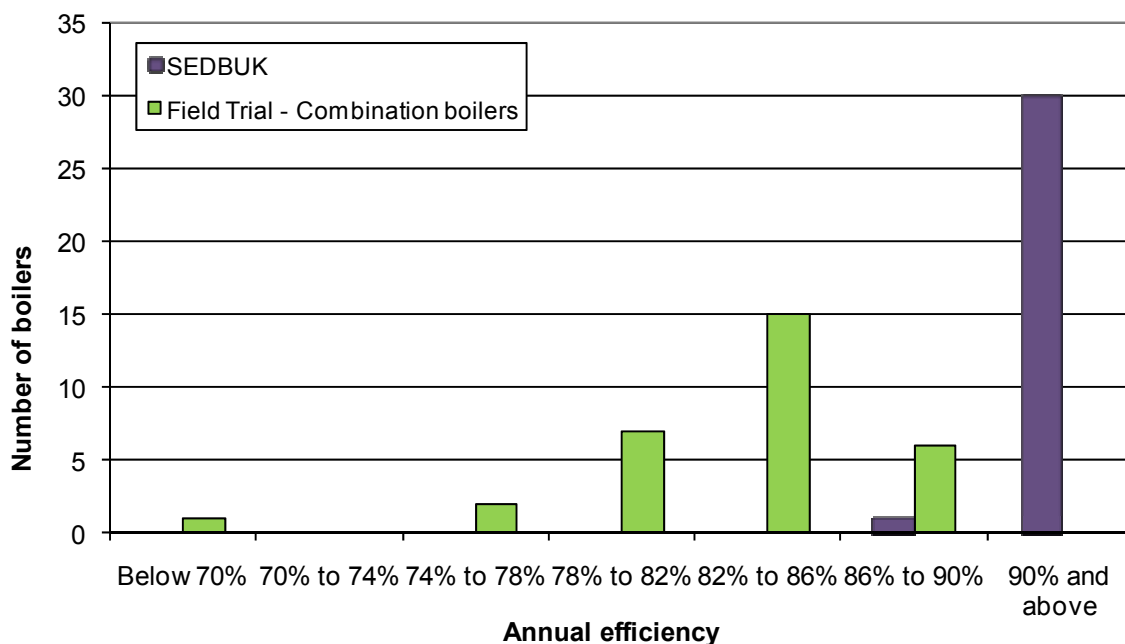
### 7.1.2 Combination boilers efficiency

Annual heat efficiencies for the thirty one individual sites with combination boilers are distributed between 89.7% and 68.6% (see Table 9 below). The mean efficiency of the sample set of combination boilers was 82.5% with a standard deviation of 4.0%. The mean of the SEDBUK rated seasonal efficiencies of the combination boilers was 90.3% with a standard deviation of 0.9%. The mean of the trial data suggests that the in situ performance of the boilers is significantly less than the rated SEDBUK seasonal efficiency. This data set suggests that the SEDBUK rated seasonal efficiency is unlikely to be observed amongst in-situ boilers.

SEDBUK tests combination boilers in space heating mode. When operating in hot water mode with intermittent demand and short draw-off periods a higher proportion of heat is wasted. Trial data represent a combination of space heating and hot water and as such does not provide a direct like for like comparison with SEDBUK, as is the case with regular boilers.

SAP includes certain performance assumptions about combination boilers; the impact of these factors is explored in Section 7.2.

Figure 15 Comparison of field trial annual **combination** condensing gas boiler performance to SEDBUK rated seasonal efficiencies



There was one SEDBUK B rated combination boiler; 328CHI, that returned a full year's data, although with a boiler breakdown occurring in the monitored period. This boiler was performing at the bottom end of the test range with an annual heat efficiency of 68.6%, which would equate to a SEDBUK rating of G.

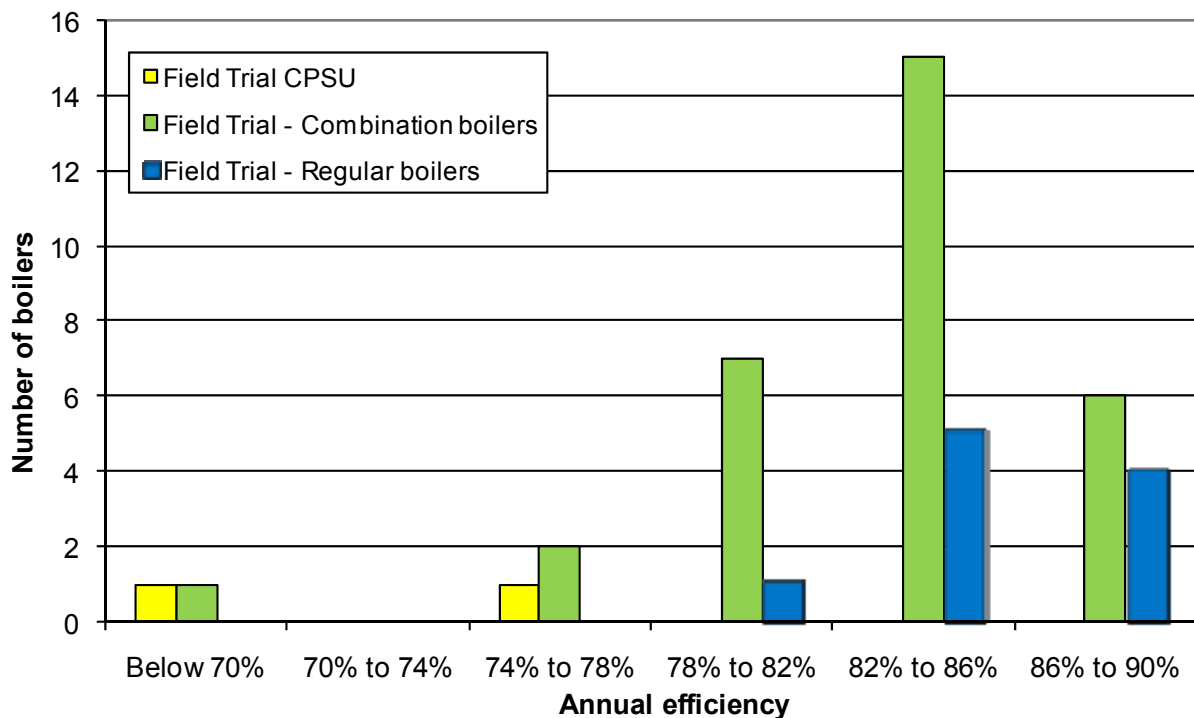
### 7.1.3 CPSU boilers combustion efficiency

There are two SEDBUK B rated CPSU boilers, 358MSC and 359NPO, that after substitution, have returned a full year's data. Compared to both combination and regular boiler results these two boilers appear to performing at the bottom end of the data set with annual heat efficiencies of 64.1% and 76.5% respectively.

These efficiencies would equate to SEDBUK ratings of G and E. Note that in terms of performance this is not a like for like comparison as CPSU boilers include an integral hot water store and associated standing losses that are not included in the SEDBUK rating for regular boilers.

There is one SEDBUK A rated combination boiler, 335RHA, which has comparable performance – an annual trial efficiency of 74.9%, E equivalent.

*Figure 16 Comparison of field trial combination, regular and CPSU condensing gas annual boiler performance*



*Table 9 Annual field trial results compared to SEDBUK - Combination boilers*

Site Ref	Boiler Type	SEDBUK seasonal efficiency	SEDBUK RATING	Field trial seasonal efficiency	Field trial equivalent rating	Variation SEDBUK & Trial
<b>343DNO</b>	Combination	90.2%	A	89.7%	B	0.5%
<b>329PLE</b>	Combination	90.1%	A	87.4%	B	2.7%
<b>319JBO</b>	Combination	91.1%	A	87.0%	B	4.1%
<b>312PLO</b>	Combination	91.2%	A	87.0%	B	4.2%
<b>356MJM</b>	Combination	91.1%	A	86.8%	B	4.3%
<b>351WIL</b>	Combination	90.1%	A	84.7%	C	5.4%
<b>347WMI</b>	Combination	91.2%	A	84.6%	C	6.6%
<b>320ETH</b>	Combination	90.1%	A	84.3%	C	5.8%
<b>309ADH</b>	Combination	90.1%	A	84.1%	C	6.0%
<b>317MTR</b>	Combination	90.1%	A	84.0%	C	6.1%
<b>307MLE</b>	Combination	90.2%	A	83.9%	C	6.3%
<b>315EJO</b>	Combination	90.3%	A	83.9%	C	6.4%
<b>339PRI</b>	Combination	90.2%	A	83.9%	C	6.3%
<b>337JDI</b>	Combination	90.8%	A	83.5%	C	7.3%
<b>352PLA</b>	Combination	90.1%	A	83.4%	C	6.7%
<b>313KPE</b>	Combination	90.1%	A	83.1%	C	7.0%
<b>344WBA</b>	Combination	90.3%	A	83.0%	C	7.3%
<b>338CNE</b>	Combination	90.7%	A	83.0%	C	7.7%
<b>311STW</b>	Combination	90.3%	A	82.9%	C	7.4%
<b>340PCU</b>	Combination	90.3%	A	82.2%	C	8.1%
<b>323RWA</b>	Combination	91.1%	A	81.6%	D	9.5%
<b>302SWI</b>	Combination	90.5%	A	81.1%	D	9.4%
<b>349JTI</b>	Combination	90.6%	A	81.0%	D	9.6%
<b>326ABR</b>	Combination	90.3%	A	80.6%	D	9.7%
<b>350AWI</b>	Combination	90.1%	A	80.6%	D	9.5%
<b>355PCA</b>	Combination	91.1%	A	80.5%	D	10.6%
<b>316MBA</b>	Combination	90.6%	A	80.1%	D	10.5%
<b>357SHO</b>	Combination	91.1%	A	78.4%	D	12.7%
<b>310MPO</b>	Combination	90.0%	A	76.6%	E	13.4%
<b>335RHA</b>	Combination	90.3%	A	74.9%	E	15.4%
<b>328CHI</b>	Combination	86.1%	B	68.6%	G	17.5%
<b>Mean</b>		<b>90.3%</b>		<b>82.5%</b>		<b>7.9%</b>
<b>Standard Deviation</b>		<b>0.9%</b>		<b>4.0%</b>		<b>3.6%</b>

Table 10 Annual field trial results compared to SEDBUK - Regular boilers

Site Ref	Boiler Type	SEDBUK rated seasonal efficiency	SEDBUK RATING	Field trial annual efficiency	Field trial equivalent rating	Variation SEDBUK & Trial
314DPA	Regular	91.2%	A	89.2%	B	2.0%
346CFR	Regular	91.2%	A	88.0%	B	3.2%
331MMU	Regular	90.4%	A	87.8%	B	2.6%
353HEB	Regular	90.8%	A	86.2%	B	4.6%
321THB	Regular	90.4%	A	85.4%	C	4.98%
341NSM	Regular	90.7%	A	85.0%	C	5.7%
325JSE	Regular	87.5%	B	83.7%	C	3.8%
345PYO	Regular	90.7%	A	83.6%	C	7.1%
327BSW	Regular	90.4%	A	82.7%	C	7.7%
336JON	Regular	90.2%	A	81.2%	D	9.0%
<b>Mean</b>		<b>90.4%</b>		<b>85.3%</b>		<b>5.1%</b>
<b>Standard Deviation</b>		<b>1.1%</b>		<b>2.5%</b>		<b>2.3%</b>

Table 11 Annual field trial results compared to SEDBUK - CPSU boilers

Site Ref	Boiler Type	SEDBUK seasonal efficiency	SEDBUK RATING	Field trial seasonal efficiency	Field trial equivalent rating	Variation SEDBUK & Trial
359NPO	Combination (CPSU)	87.4%	B	76.5%	E	10.9%
358MSC	Combination (CPSU)	87.3%	B	64.1%	G	23.2%

## 7.2 Comparison of trial results with SAP seasonal efficiency

As mentioned above the SEDBUK rated seasonal efficiency is one part of the indication of boiler performance as modelled in SAP. A significant number of 'in use' correction factors are applied dependent on boiler type, controls and insulation. In the context of the trials some of these factors are difficult to determine without extensive house surveys.

### 7.2.1 Regular boilers

Whilst the calculated trial efficiency of regular boilers can be compared with SEDBUK values when used in SAP, care must be taken in the comparison with trial results for combination boilers as the heat efficiency calculation for regular boilers does not take into account standing losses from primary pipework and hot water cylinders. These losses need to be taken into account to ensure a like for like comparison. An approximate calculation from SAP (Table 12) indicates that losses from un-insulated primary pipework and an older lagged hot water cylinder with thermostat are approximately 2500kWh pa. Insulated pipework and factory fitted insulation would

halve these losses, a proportion of which are also usefully contributing to space heating demand.

*Table 12 Example losses form primary pipework and hot water cylinder calculated from SAP Table 3*

	kWh/yr
Boiler with insulated primary pipework and with 180l cylinder thermostat (pipework.1.5m) insulation thickness - new cylinder - 50mm factory fitted	1232
Boiler with un-insulated primary pipework and with 180l cylinder thermostat (pipework.1.5m) insulation thickness - new cylinder - 50mm factory fitted	2254
Boiler with un-insulated primary pipework and with 180l cylinder thermostat (pipework.1.5m) insulation thickness - existing cylinder - 50mm lagging	2504

The mean of the measured annual efficiencies of the regular boilers in the trials was 85.3% +/- 1.8%. From Table 12 a trial average of tank and primary pipework losses are roughly estimated at 1800kWh per year and, if 50% of the losses are useful as space heating, on an annual basis, this gives a net annual loss of 900kWh. This would reduce the effective overall efficiency of the boiler in terms of useful heat output, by about 5% based on a typical annual heat output of 15,000kWh. Thus a more valid mean regular boiler annual efficiency may be 80.3%

## 7.2.2 Combination boilers

Efficiency for a combination boiler in the trial is calculated from addition of space heating and DHW readings divided by boiler gas consumption. SAP includes certain performance assumptions about combination boilers, the most significant of which is combi heat loss. Table 3 of SAP assumes that an instantaneous combination boiler with no keep hot facility, or an instantaneous combination boiler and a keep hot facility controlled by a time clock, will waste 600kWh of heat per year, independent of property size and therefore demand. This waste water is included in the annual calculated trial efficiency and should be represented in the comparison with SEDBUK seasonal efficiency.

Of the 31 combination boilers with annual data sets, 29 are listed in SEDBUK as being instantaneous and four with timer controlled keep hot facility. No boilers are recorded as having load compensation.

It was considered that the data from the boiler trials might inform an improved estimation of hot water losses from combination boilers than a flat figure of 600kWh/yr. The efficiency of trial boilers when producing DHW was investigated further by isolating the summer months where it was expected that there would be no space heating demand. This analysis is discussed below.



### 7.2.3 Analysis of domestic hot water efficiency

Analysis of the summer water heating efficiencies was made difficult by the heat meters not accurately recording small water flows and significant amounts of stop/start operation. This resulted in poor energy balances being recorded for combination boilers. There were also varying amounts of space heating observed in the three month summer period.

GaC carried out a laboratory investigation into why poor closures were experienced. This issue was reported separately for the EST and is summarised above in section 5.4. The results of the tests found that with very short domestic hot water draw offs, the instantaneous heat to gas efficiency was much lower than expected which was found to be a result of flue loss and heat going to the boiler metalwork, losses which were estimated not measured in the trial sites.

In addition to higher than expected losses, tests of different draw-off cycles found that heat meters used in the trials have a significant delay in responding to changes from zero flow. In heating situations, the long periods of operation make this error negligible, but during short DHW draw offs it becomes significant resulting in reduced heat flow recorded. Both of these factors lead to reductions in the calculated heat efficiencies. For the purpose of summer DHW assessment alone, an adjustment of 25% was made to increase the heat recorded by the heat meters to attempt to reflect the 'true' DHW use. After adjustment the combination boilers gave an average summer efficiency of 73% including a certain amount of space heating but there was large variation in heat efficiency from less than 40% to above 80%.

Whilst the regular boilers were found to be efficient for delivering DHW to the cylinder, (average heat efficiency ~80%, excluding primary pipework losses), the recorded heat delivered to taps was much lower. Even after adjustment was made for the low heat meter readings under DHW draw-off, the mean efficiency of heat delivered to the taps was only ~40%, and much lower where little DHW is used (adjusted range is ~15% to ~65%). To be able to calculate these figures we have assumed no space heating was provided in the summer months, whereas in fact some summer space heating was recorded in the trial. Due to the location of heat meters on regular boilers it is not possible to split the demands so where there is some space heating provided this will be represented as additional losses. It is likely that actual efficiencies for water heating will therefore be slightly higher. Cylinder and primary pipework losses for the three month period are estimated from SAP at between 400 and 600kWh compared to a mean heat output from the boilers of 845kWh. This indicates that losses from cylinder and primary pipework are likely to be the cause of the low net efficiencies for DHW used for regular boilers.

It is very difficult to compare the summer performance of the regular and combination boilers due to different measurement points and summer space heating which will have a significant effect on boiler run times and hence efficiencies. Whilst the regular boilers achieved a summer efficiency of ~80%, it is estimated that only about half of this heat was used in hot water delivered to the taps, the rest being lost from the cylinder and primary pipework therefore actual efficiency of DHW supply for regular boilers with hot water cylinders might be as low as 40%. After adjustment the combination boilers gave an overall hot water efficiency of efficiency of ~73%.

The losses associated with DHW production were further investigated by GaC. Figure 17 and Figure 18 compare summer gas consumption to adjusted domestic hot water demand and an estimate of associated losses.

Figure 17: Boiler Losses: Regular boilers (daily average over summer season)

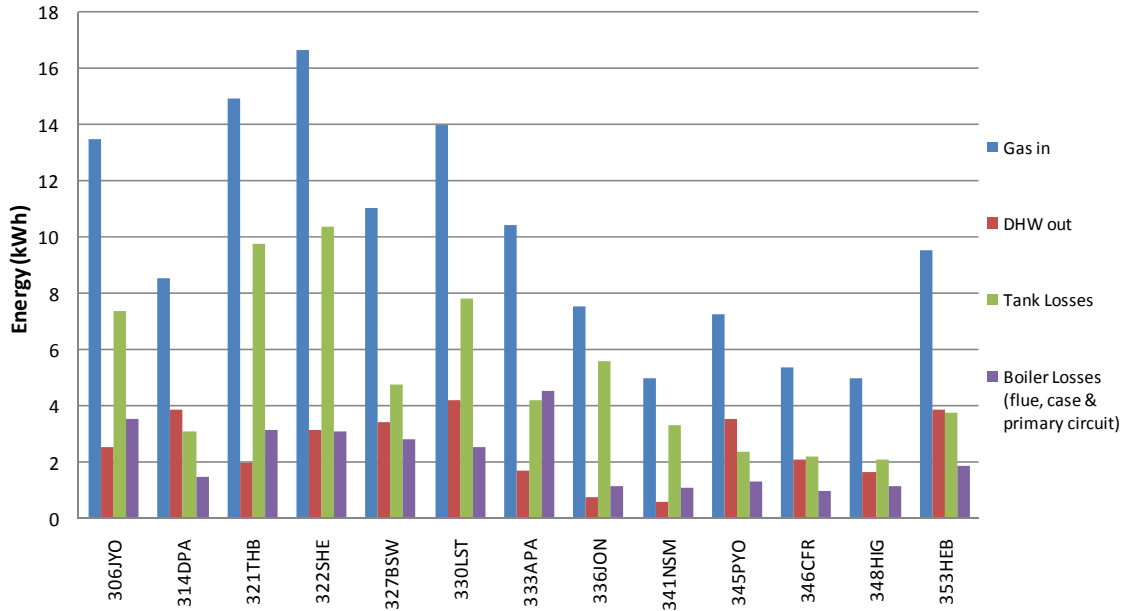
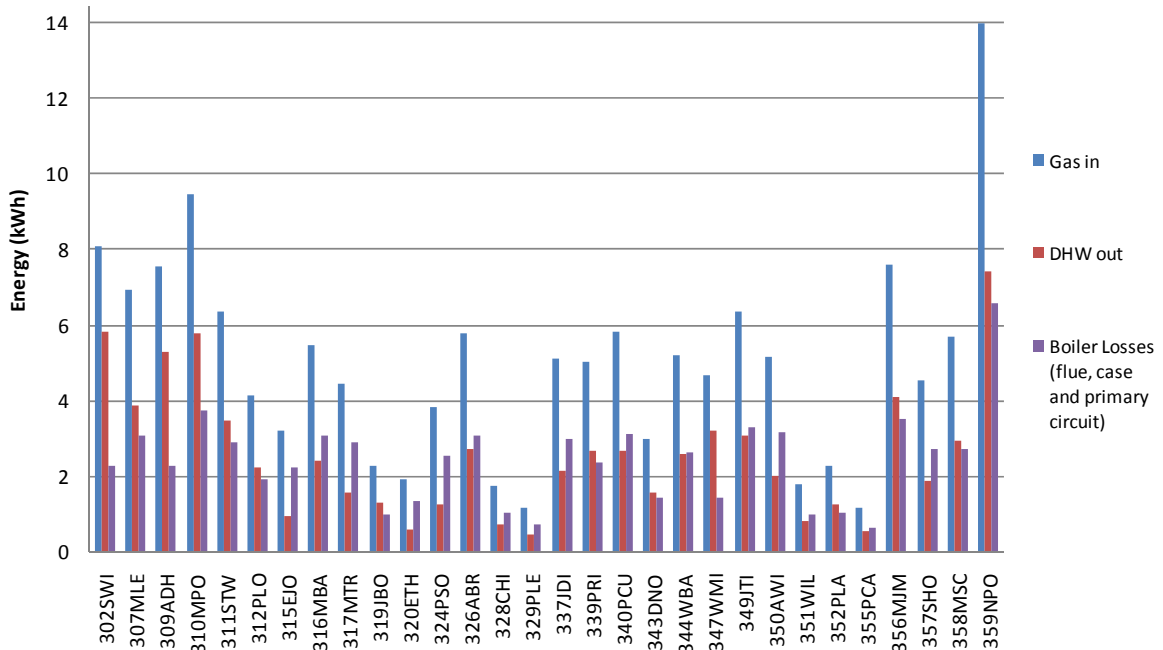


Figure 18: Boiler Losses: Combination boilers (daily average over summer season)



*Table 13 Daily average losses associated with summer DHW production*

	<b>Combi</b> KWh/day	<b>Regular</b> KWh/day
Gas in	5.13	9.89
DHW out	2.69	2.58
Tank Losses	NA	5.13
Boiler Losses	2.42	2.22

Table 13 reports average adjusted summer hot water demand from the trial and estimated tank and boiler losses. Table 13 highlights the different factors that affect the efficiency of DHW production when considering regular and combination boilers. In summary:

- The efficiency of regular boilers is dominated by **standing losses**; therefore very small **total** draw means low efficiency, whereas;
- The efficiency of combination boilers is dominated by the **length of individual draw offs**, thus very small **individual** draw means low efficiency.

Daily average summer hot water draw off is very consistent between regular and combination boilers at around 2.6kWh. This can be compared to an annual average of adjusted monitored daily hot water demand of 4.7kWh/day for combination boilers and 5.1kWh/day for regular boilers. Lower summer demands are likely to be due to higher cold water feed temperatures. Mains temperatures are known to rise in summer months which will reduce combination boiler energy demand. For regular boilers, mains water is generally stored in cold water storage tanks located in un-insulated loft spaces. In summer months loft spaces will be hotter than the ground and act to pre heat the cold water supply.

These results also compare well to those reported in the final report of the separate EST field trial 'Measurement of Domestic Hot Water Consumption in Dwellings'<sup>7</sup> This study reported data from 69 regular boilers and 38 combis and showed a mean DHW demand of  $16.8 \pm 2.2$  MJ/day equivalent to  $4.67 \pm 0.61$  kWh/day.

<sup>7</sup> Chris Martin, Energy Monitoring Company, March 2008.

#### **7.2.4 Comparing the annual efficiency of regular boilers with DHW storage, with combination boilers**

The average of the measured annual efficiencies of the regular boilers in the trials was nearly 3% better than the combination boilers, 85.3% as opposed to 82.5%. The difference is thought to be due to the lower efficiency of combination boilers when operating in DHW mode (about 73%). However it should be remembered that the regular boiler efficiency is measured in terms of heat input to the DHW cylinder and some of this is lost due to storage cylinder and primary pipework losses and is never used as hot water. Tank and primary pipework losses are roughly estimated at 900kWh per year. This would reduce the effective overall efficiency of the boiler in terms of useful heat output, by about 5% based on a typical annual heat output of 15,000kWh.

Thus a more valid comparison of regular and combination boiler annual efficiency may be 80.2% compared with 82.5%. Precise comparisons on a property by property basis are difficult because, as indicated elsewhere, combi boilers are much more efficient when producing large volumes of water per draw off (e.g. water for a bath is produced more efficiently than for a hand-wash); very differently the DHW efficiency of a regular boiler is a function of the total daily draw. This is why when comparing the efficiency of DHW production a standard pattern must be chosen. Currently SAP uses approximately 100l DHW/day (~5.8kWh) as defined with EU Mandate M324 Table 2 for a 100m<sup>2</sup> property and these investigations show no substantive reason to change this.

#### **7.3 Recommendations to improve the representation of the annual efficiency of combination boilers in SAP**

The SEDBUK efficiency of combination boilers is based on tests in central heating mode, as traditionally this has been the source of the majority of heat output. SAP uses the boiler efficiency in SEDBUK and applies it to the total of space and DHW heating demand, and adds in a figure of 600kWh per year heat loss (Table 3a) to allow for the lower efficiency in DHW mode. This figure is used irrespective of how much DHW is estimated to be used.

With improvements to building fabric performance, DHW is becoming a larger proportion of annual household heating demand. Consequently the boiler performance in DHW mode becomes an important factor in the calculation of gas demand. Boiler efficiency is known to be lower in domestic hot water mode than in space heating mode (approximately 73% compared with 83%) and is dependant of volume of DHW used and draw-off pattern. The efficiency in DHW mode is known to vary widely according to the precise design of the boiler at least across the range 70% to 40% (GaC in-house data).

A revised SAP calculation is proposed in which the energy use for space heating and DHW is calculated separately, based on laboratory test efficiencies of combination boilers in both modes. The use of the applied 600kWh heat loss factor could then be dropped. This will provide a more accurate estimate of annual energy use by combination boilers and will also have the effect of encouraging the boiler manufacturers to improve the efficiency of combination boilers in DHW mode, an area that may have been neglected to date.

The following equation is suggested:

$$\text{SAP Combination boiler efficiency } (\eta_{\text{SAP}}) = \frac{\text{SH} \cdot 0.95 \cdot \eta_{\text{SEDBUK}} + \text{DHW} \cdot \eta_{\text{M324}}}{(\text{SH} + \text{DHW})}$$

<b>SH</b>	Energy to space heating kWh
<b>0.95</b>	Factor correcting for performance in CH mode to modern conditions (as proposed for regular boilers)
$\eta_{\text{SEDBUK}}$	SEDBUK value rated seasonal efficiency %
<b>DHW</b>	Energy to DHW kWh
$\eta_{\text{M324}}$	Efficiency of DHW from EU Mandate M324 (Table 2) %

### 7.4 Space and DHW heating

The graphs below illustrate the correlation between gas used and space and water heating provided over the 12 month period. Both graphs indicate a strong correlation between space heating and gas consumption (as would be expected). For DHW provision, the results show a spread of hot water demand between 0 and 400kWh/month.

Whilst space and hot water are measured separately for combination boilers, for regular boilers space heating is calculated from total heat, minus hot water. Therefore space heating will be underestimated due to hot water meter reading inaccuracies and losses from primary pipework and hot water cylinder.

Figure 19 Space and water heat supplied against gas consumed kWh: Combination Boilers

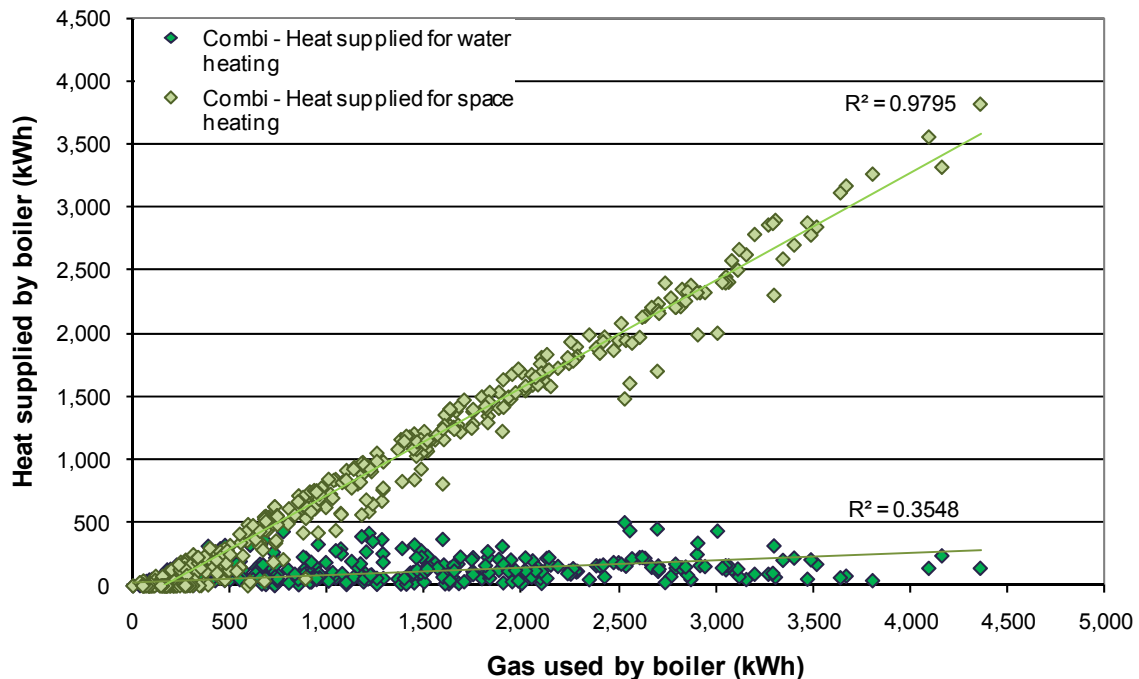
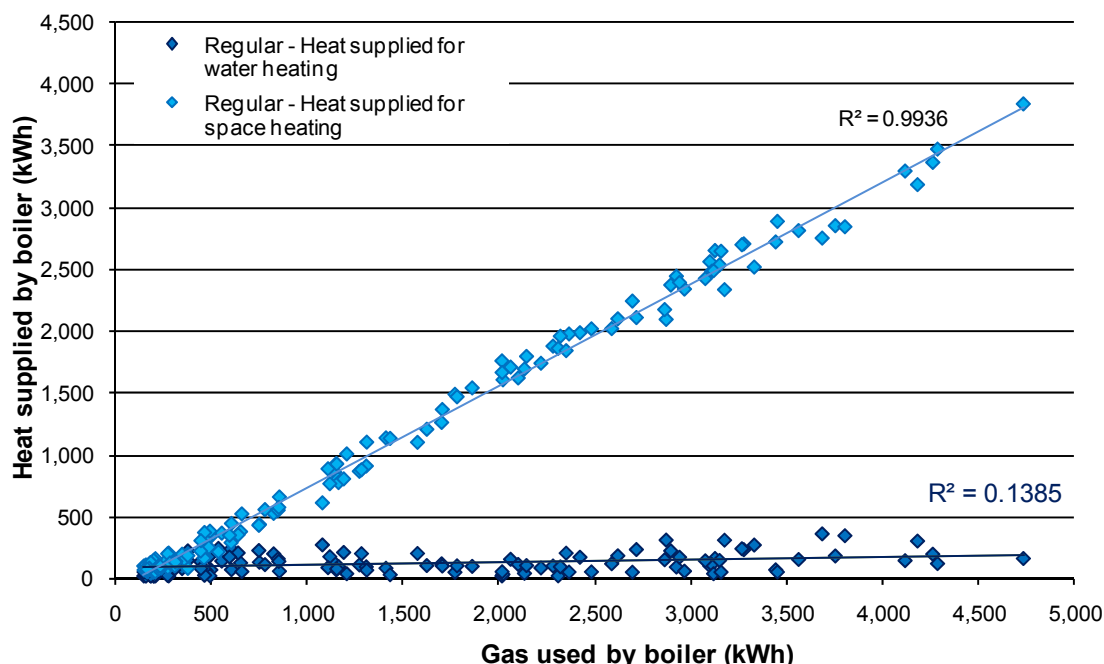


Figure 20: Space and water heat supplied against gas supplied kWh: Regular Boilers



## 7.5 Annual monitored carbon benefits ratio (CBR)

The CBR includes the electrical consumption of the boiler in the calculation of boiler efficiency (see Section 6.3. Boiler efficiency and carbon benefits ratio defined). Originally developed to allow comparison between the performance of micro CHP units and condensing gas boilers, a comparison CBR gives a measure of whole system efficiency, weighted for carbon emissions, as opposed to simple heat efficiency alone. Note that whilst CPSU units are included in this comparison the results are from only two installations.

Table 14 Average monthly efficiency and CBR across trial

	Combination (31)		Regular (10)		CPSU (2)	
	Efficiency	CBR	Efficiency	CBR	Efficiency	CBR
<b>Jul</b>	70%	63%	81%	73%	53%	49%
<b>Aug</b>	66%	57%	80%	72%	55%	52%
<b>Sep</b>	75%	68%	81%	75%	63%	59%
<b>Oct</b>	82%	77%	84%	80%	74%	71%
<b>Nov</b>	85%	81%	85%	83%	78%	75%
<b>Dec</b>	86%	82%	85%	83%	80%	76%
<b>Jan</b>	86%	82%	85%	83%	78%	75%
<b>Feb</b>	86%	82%	85%	83%	78%	75%
<b>Mar</b>	86%	82%	85%	83%	76%	73%
<b>Apr</b>	85%	81%	85%	83%	75%	72%
<b>May</b>	79%	73%	84%	79%	61%	57%
<b>Jun</b>	70%	63%	82%	75%	47%	44%
<b>12 months</b>	84%	79%	85%	82%	73%	70%

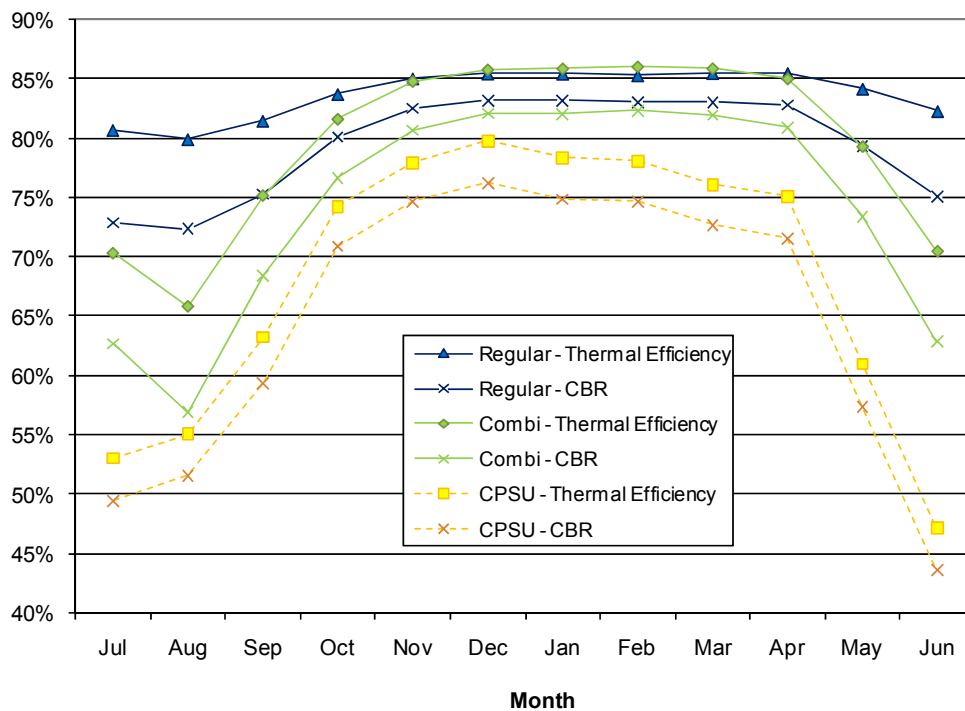
Figure 21 represents the results shown in Table 14 comparing the monthly trial average efficiencies with carbon benefits ratio between boiler types. Monthly averages were calculated from the sum of 12 month accepted data and are not an average of the individual boiler efficiencies shown in Table 9 and Table 10.

Taking a trial monthly average weights the results according to boiler usage and as such it can be seen that over the winter heating season (Nov-Apr) when heat output is predominantly for space heating, there is no significant difference in heat efficiencies between boiler types. Comparing the average CBR over the winter months between combination and regular condensing boilers indicates a slightly poorer CBR for combination boilers than regular boilers. This might suggest a higher electrical consumption per unit of heat supplied.

In the non heating months, when heat output is dominated by DHW production, there is an apparent marked reduction in monitored efficiency of combination boilers as compared to regular boilers. Calculated efficiencies are influenced by energy closure with poor closures being one factor that can result in low calculated efficiencies.

As is observed with both combination and regular boiler efficiencies, the CPSU boilers show maximum efficiency over the heating period with significant reductions in non heating months. This is likely to be due in part to the standing losses from the integrated hot water cylinder. It might be expected that if the calculation of efficiency was for delivered heat and therefore for regular boilers included losses from primary pipe work and hot water cylinder, a similar drop in performance over summer months might be observed.

Figure 21 Mean monthly heat efficiency (%) and CBR (%) across trial





## 7.6 Monthly heat efficiency and heat demand

Figure 22, Figure 23 and Figure 24 below show the distribution of monthly data points of calculated heat efficiency plotted against monitored heat supplied. Heat efficiency of regular boilers remains above 80% for 105 (88%) of the 120 recorded months of trial data, with some reduction in performance of some units when less than 500-600kWh heat is supplied per month. Of the 56 months of data with less than 600kWh heat supplied, 15 (27%) of recorded months show a calculated efficiency of less than 80% compared to none when heat supplied was above 600kWh per month.

Heat efficiency of combination boilers shows a more marked reduction when less than 1000kWh heat is supplied per month. Of the 211 months of data with less than 1000kWh heat supplied, 151 (72%) of recorded months show a calculated efficiency of less than 80%.

Heat efficiency of CPSU boilers shows a trend of reducing performance with reducing kWh heat supplied. Performance appears to drop more rapidly below approximately 600-700kWh. This data set is very small but there is a good correlation between these variables.

Figure 22 Monthly heat efficiency (%) against heat supplied - regular boilers

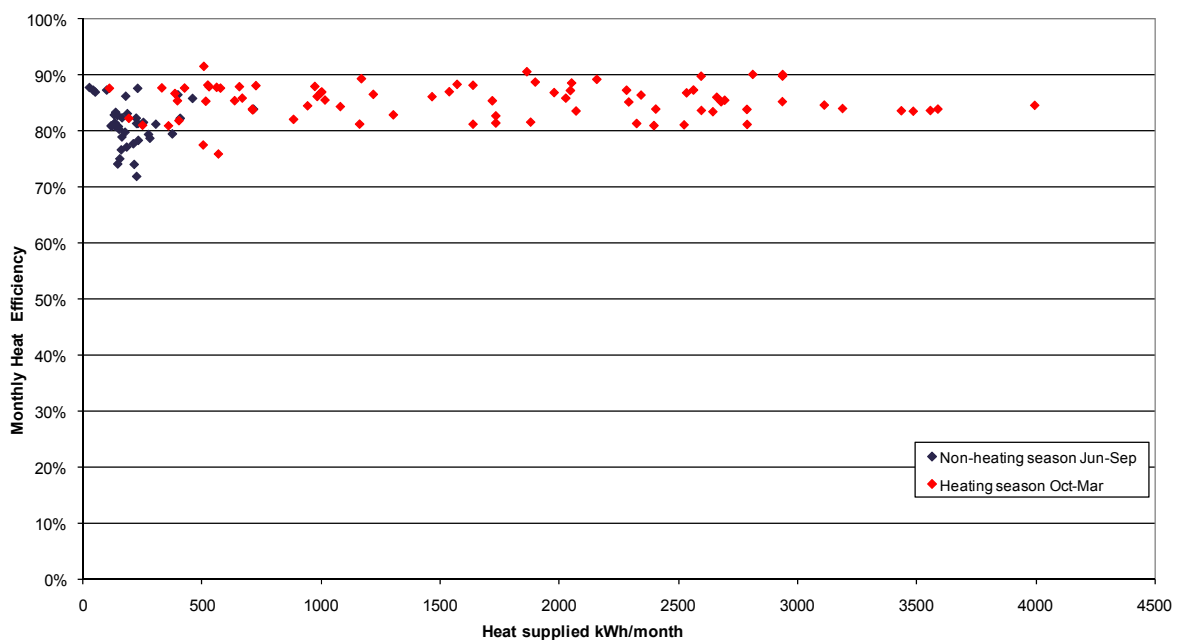


Figure 23 Monthly heat efficiency (%) against heat supplied - combination boilers

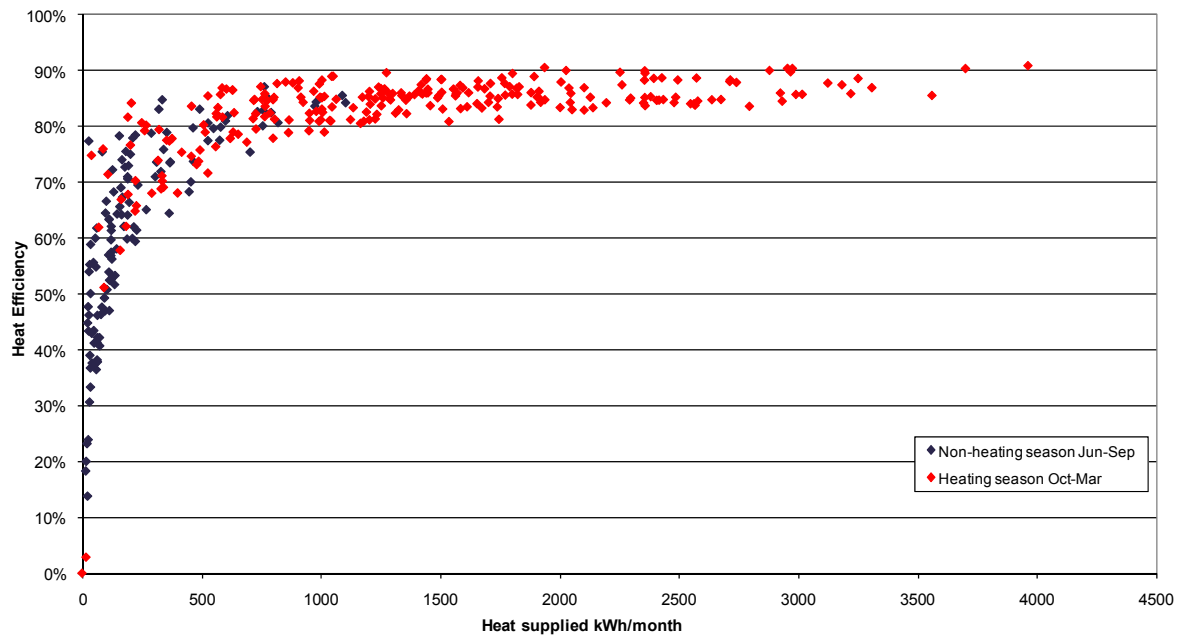
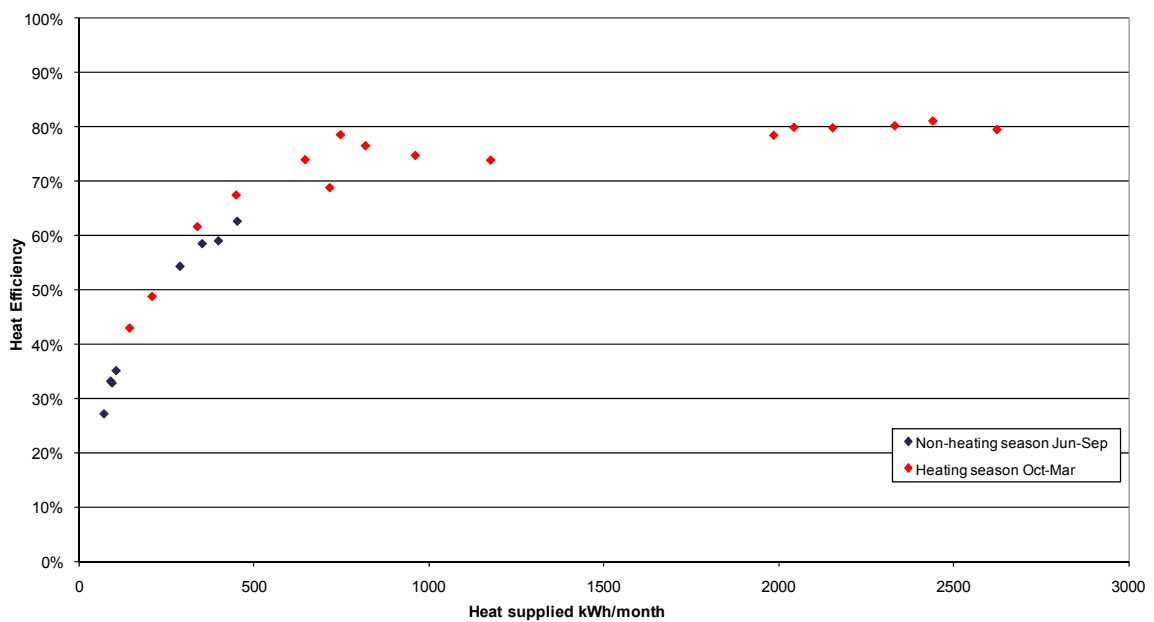


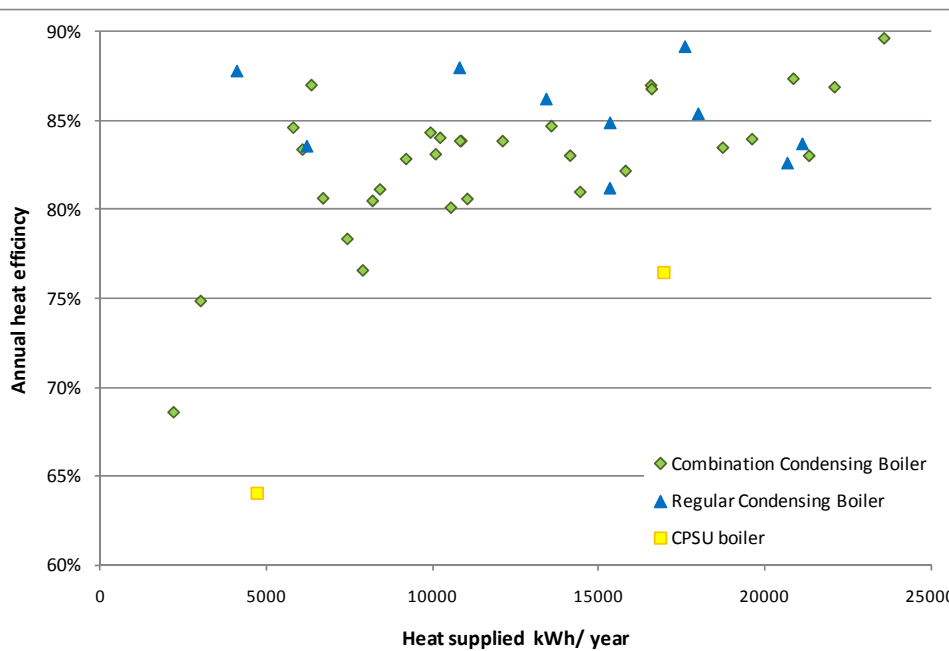
Figure 24 Monthly heat efficiency (%) against heat supplied - CPSU boilers



## 7.7 Annual heat efficiency and heat demand

Figure 25 plots calculated annual heat efficiency against annual heat demand. From inspection for combination boilers there appears to be a weak positive correlation between the two variables, regular boilers show no apparent correlation and there are too few CPSU boilers to comment on trends.

Figure 25 Annual heat efficiency (%) against heat supplied - all boilers



### 7.8 Load factor and boiler efficiency

Figure 26 plots calculated monthly heat efficiency against boiler load factor. From inspection there appears to be a positive relationship between the two at low load factors (below 5%). Beyond this point no relationship is obvious and the data appears to plateau indicating that heat efficiency is generally independent of load factor above a load factor of approximately 5%.

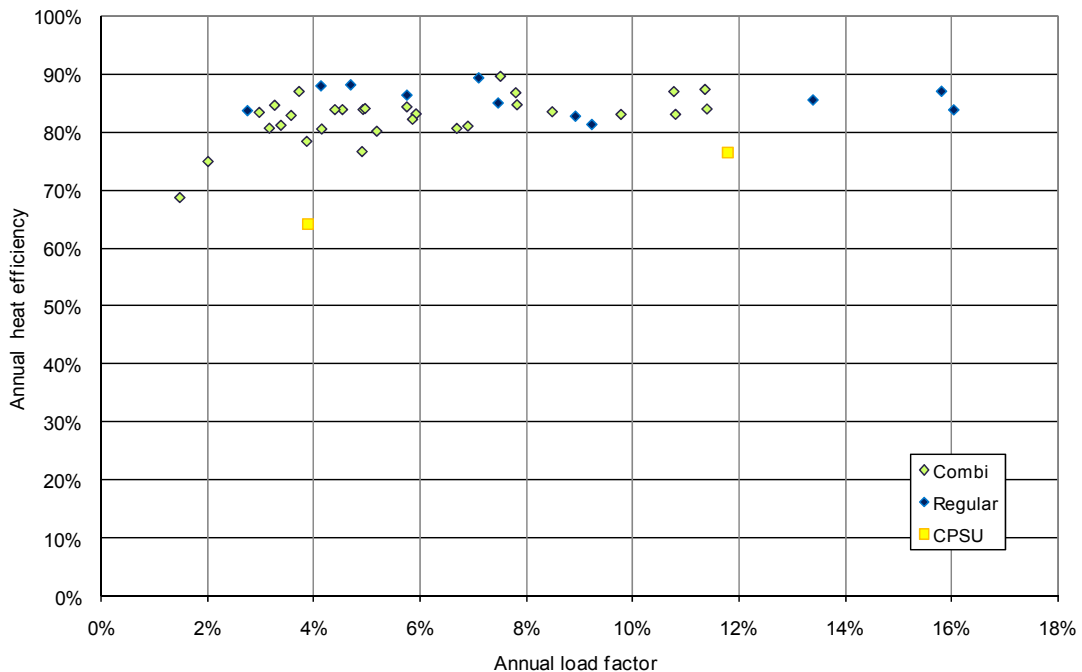
The majority of data recorded for load factors below 5% relate to summer, hot water led, operation where there is a prevalence of poor data closure. It is considered likely that were better data closures observed, better efficiencies would be observed at load factors below 5%.

Figure 26 Monthly heat efficiency against load factor by boiler type



When reviewed on an annual basis (Figure 27) there is no obvious correlation between load factor and heat efficiency in the field trial data set. This is unsurprising as overall heat efficiency is dominated by high space heating loads when the boiler is operating at high load factor.

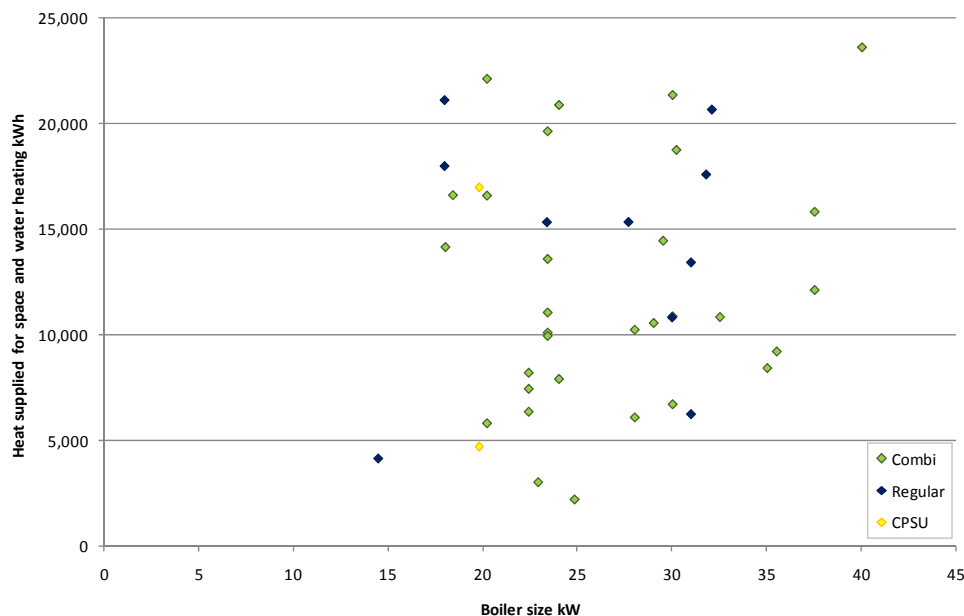
Figure 27 Annual heat efficiency against load factor



## 7.9 Boiler size and heat supplied

Figure 28 compares installed boiler size with heat supplied (a proxy for heat demand assuming adequate boiler sizing). There is no apparent correlation between these factors. If installation guidance relating to boiler sizing was followed, it would be expected that there would be a correlation between these two variables.

Figure 28 Annual heat supplied for space and water heating against boiler size

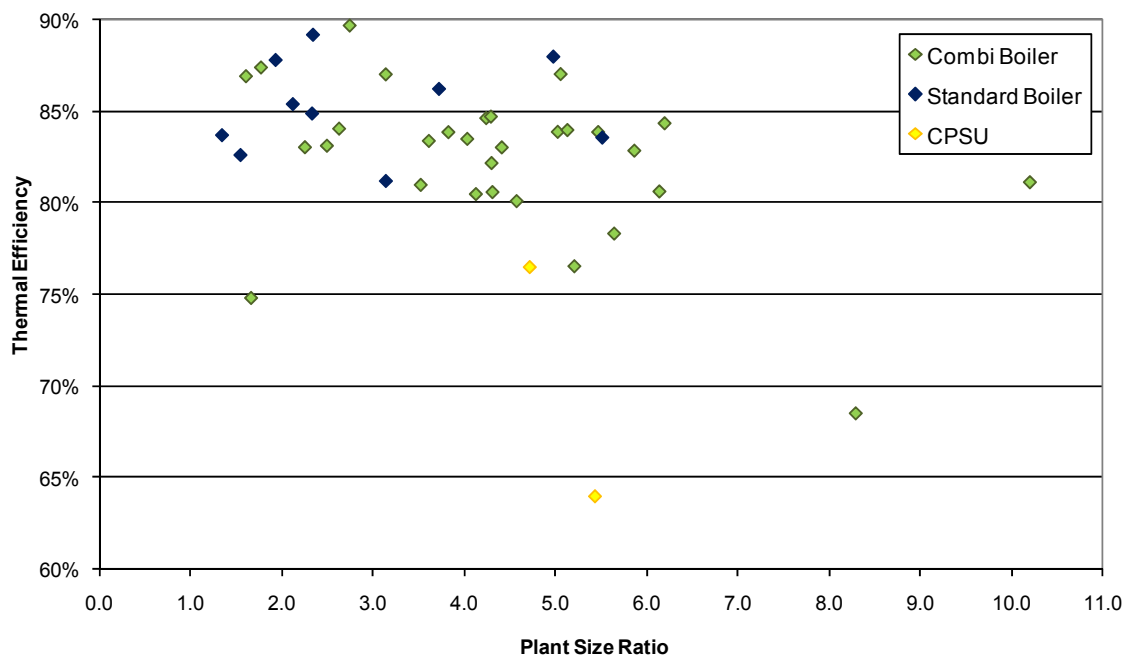


This lack of correlation supports the view that choice of boiler size is based on decisions by the boiler installer and their beliefs of necessary boiler sizes which may be independent of house size, household usage patterns and heat loss.

Figure 29 compares heat efficiency to boiler size ratio. The boiler size ratio (or plant size ratio) is a measure of how well the boiler is sized for the property. It is defined as the ratio of the kW rating of the installed appliance and the maximum heat demand of the property. The closer the figure is to 1 the better the sizing of the appliance. Less than 1, the boiler is inadequate to heat the house, greater than 1, the boiler is oversized and this may lead to frequent cycling; especially when considerably oversized. Boiler sizing really only applies to regular boilers as many combination boilers will be considerably over sized to satisfy the DHW requirement.

It is likely that all boilers are “oversized” during most of their operating time, particularly in warmer weather. Peak demand will only occur for short periods of time even with a plant size ratio of 1 and at other times the boiler will modulate and if necessary cycle, to provide the heat demand. It was expected that significantly oversized boilers would have a greater incidence of cycling which would manifest in reduced heat efficiency. Figure 29 indicates that oversizing the boiler does not, on its own, result in a noticeable trend towards a reduced efficiency, for either regular or combination boilers. Although cycling will incur flue heat loss and purge losses, other factors such as lower return temperatures may improve efficiency mitigating any significant reduction in performance from cycling.

Figure 29 Thermal efficiency plotted against plant size ratio



### 7.10 Analysis of boiler electrical consumption

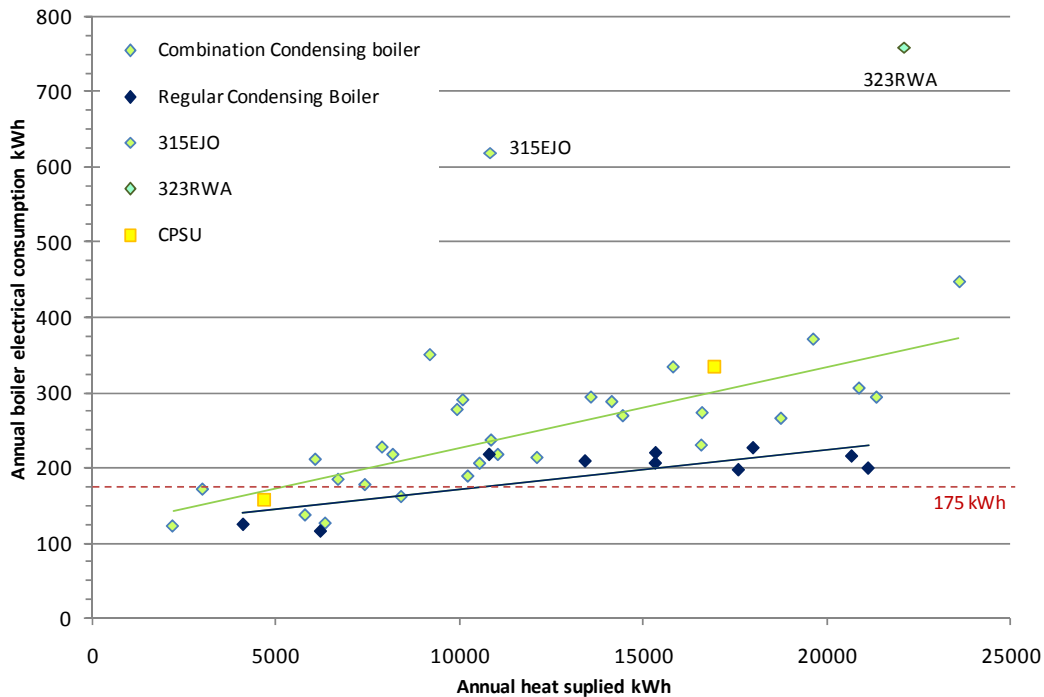
Trial data indicates on average combination boilers use around 30% more electricity to supply 10,000kWh of heat than regular boilers and around 50% more electricity to supply 20,000kWh heat.

Approved documents L1A and L1B of the Building Regulations stipulate minimum SEDBUK heat efficiency requirements for installations of condensing gas boilers in new build and existing dwellings. There is no comparable stipulation for the electrical efficiency of pumps and fans associated with the boiler. Higher boiler electrical consumption per unit of heat delivered results in a lower CBR and higher carbon emissions per unit of heat delivered to the dwelling.

Dependant on controls, SAP 2005 assumes 45kWh/yr of electricity is used by fans and 130kWh/yr by central heating pumps. For combination boilers with an electric keep hot facility SAP also assumes 600kWh/yr electricity where the keep hot facility is controlled by a time clock and 900kWh without. Of the 33 combination boilers in the final data set 2 boilers, 325JSE and 329PLE, are listed on SEDBUK as being supplied with an electric keep hot facility. Trial monitoring of boiler electricity use of these two sites indicates comparable electrical consumption to other trial sites and does not indicate that this facility is being utilised.

The annual consumption of electricity for fans, pumps and control systems for all 43 condensing gas boilers is shown in Figure 30.

Figure 30 Annual electricity used against heat supplied



Boiler electrical consumption in the trial ranges from around 100kWh/year for 2500-6000kWh/year heat supplied to 200-400kWh for 20,000kWh heat supplied. Two boilers show annual consumption above 600kWh/year. 80% of boilers recorded annual electrical consumption of greater than the SAP assumption of 175kWh.

On average trial data indicates combination boilers use around 30% more electricity to supply 10,000kWh of heat than regular boilers and around 50% more electricity to supply 20,000kWh heat.. There is a wide variation in electrical consumption across the sample. Different combination boilers supplying comparable amounts of heat per year, show up to a 40% difference in electrical consumption between the lowest consumers to the highest consumers. Regular boiler installations show less pronounced variation, up to 15%, however the sample size for regular boilers is much smaller.

It might be expected that combination boilers would use greater amounts of electricity than regular boilers as the boiler has to fire for every DHW draw-off and (where fitted) to maintain the temperature of the keep-hot vessel. Numerical evaluation (using reasonable assumptions) does not explain more than about 25kWh/year. The data shows a positive correlation between power consumption and delivered heat which is dominated by central heating demand. It is known that combis and system/regular boilers have can have different control strategies, but the magnitude of the difference is unexpected. Further work is recommended to investigate the cause of this difference.

Boilers 315EJO and 323RWA have significantly higher electrical consumption than the other boilers and this is likely to be due to incorrect control settings resulting in



the pump running for extended periods or excessive boiler cycling. GaC have investigated the gas and electrical consumption in the property 323RWA (regular condensing boiler). Reviewing boiler performance at 5 minute intervals in January 2008 it was determined that that the pump is always running in this property and the boiler, although modulating down operates continuously. Pump operating hours/month are dependent upon the setting of the room-stat in combination with any TRVs. If the roomstat is never satisfied, the pump will run for as many hours as allowed by the time clock. Table 15 has been generated in-house by GaC from typical boiler data. The table shows 3 operating regimes for a 30kW boiler; boiler operating on demand, bimodal firing and continual firing. The upper sheet assumes average operation at 60% turn-down (60% boiler output), the lower at 30% turndown (30% boiler output). This theoretical analysis appears to explain the monitored data.

Boiler electricity consumption has also been compared with heat efficiency to examine any potential relationship between the two. It might be plausible for more efficient heat exchangers to require greater pumping power, or for a longer pump overrun to reduce heat lost up the flue. However annual results, plotted below do not indicate any obvious correlation between these two factors.

Figure 31 Annual heat efficiency against boiler electricity use – All sites

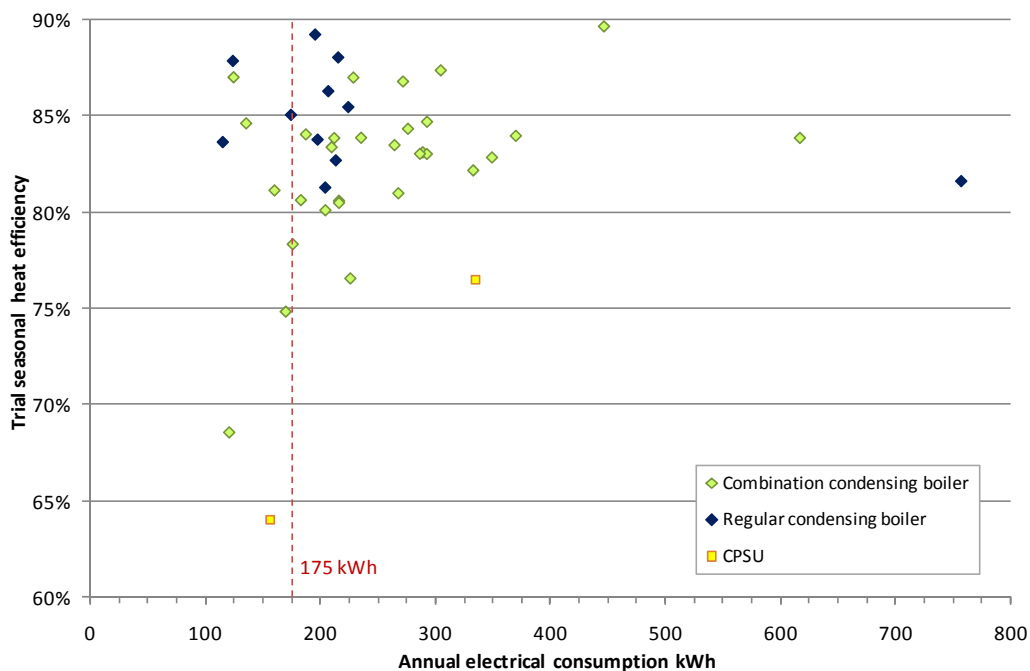


Table 15: Typical boiler electrical consumption at 60% and 30% pump turn down

60% Turn down	Boiler operating on Demand				Boiler operating bi-modally				Boiler operating continually			
GAS kWh/month	500	1500	2500	3500	500	1500	2500	3500	500	1500	2500	3500
Boiler kW	30	30	30	30	30	30	30	30	30	30	30	30
Mean output %	60	60	60	60	60	60	60	60	60	60	60	60
Av kW	18	18	18	18	18	18	18	18	18	18	18	18
Gas hrs/month	27.78	83.33	138.89	194.44	27.78	83.33	138.89	194.44	27.78	83.33	138.89	194.44
Standby hrs/mnth	698.22	642.67	587.11	531.56	698.22	642.67	587.11	531.56	698.22	642.67	587.11	531.56
Fan Controls W <sup>+</sup>	60.00	60.00	60.00	60.00	60.00	60.00	60.00	60.00	60.00	60.00	60.00	60.00
Total FandC kWh	1.7	5.0	8.3	11.7	1.7	5.0	8.3	11.7	1.7	5.0	8.3	11.7
Standby W	15.0	15.0	15.0	15.0	15.0	15.0	15.0	15.0	15.0	15.0	15.0	15.0
Total Standby kWh	10.5	9.6	8.8	8.0	10.5	9.6	8.8	8.0	10.5	9.6	8.8	8.0
Pump W	60	60	60	60	60	60	60	60	60	60	60	60
Pump Hrs	Demand	Demand	Demand	Demand	9/day	9/day	9/day	9/day	Cont	Cont	Cont	Cont
Pump Total kWh	1.7	5.0	8.3	11.7	16.3	16.3	16.3	16.3	43.6	43.6	43.6	43.6
TOTAL kW Elec cons	13.8	19.6	25.5	31.3	28.5	31.0	33.5	36.0	55.7	58.2	60.7	63.2
30% Turn down	Boiler operating on Demand				Boiler operating bi-modally				Boiler operating continually			
GAS kWh/month	500	1500	2500	3500	500	1500	2500	3500	500	1500	2500	3500
Boiler kW	30	30	30	30	30	30	30	30	30	30	30	30
Mean output %	30	30	30	30	30	30	30	30	30	30	30	30
Av kW	9	9	9	9	9	9	9	9	9	9	9	9
Gas hrs/month	55.56	166.67	277.78	388.89	55.56	166.67	277.78	388.89	55.56	166.67	277.78	388.89
Standby hrs/mnth	670.44	559.33	448.22	337.11	670.44	559.33	448.22	337.11	670.44	559.33	448.22	337.11
Fan Controls W <sup>+</sup>	60.00	60.00	60.00	60.00	60.00	60.00	60.00	60.00	60.00	60.00	60.00	60.00
Total FandC kWh	3.3	10.0	16.7	23.3	3.3	10.0	16.7	23.3	3.3	10.0	16.7	23.3
Standby W	15.0	15.0	15.0	15.0	15.0	15.0	15.0	15.0	15.0	15.0	15.0	15.0
Total Standby kWh	10.1	8.4	6.7	5.1	10.1	8.4	6.7	5.1	10.1	8.4	6.7	5.1
Pump W	60	60	60	60	60	60	60	60	60	60	60	60
Pump Hrs	Demand	Demand	Demand	Demand	9/day	9/day	9/day	9/day	Cont	Cont	Cont	Cont
Pump Total kWh	3.3	10.0	16.7	23.3	16.3	16.3	16.3	16.3	43.6	43.6	43.6	43.6
TOTAL kW Elec cons	16.7	28.4	40.1	51.7	29.7	34.7	39.7	44.7	57.0	62.0	67.0	72.0

### 7.11 Internal and external temperature analysis

Figure 32 illustrates the distribution of data for average monthly internal temperature and external temperature. Over 60% of homes maintain their internal temperature between 15°C and 20°C over the heating season with a mean for the data set of 18°C represented by Figure 33.

Figure 32 Heating season monthly average internal vs. external temperature

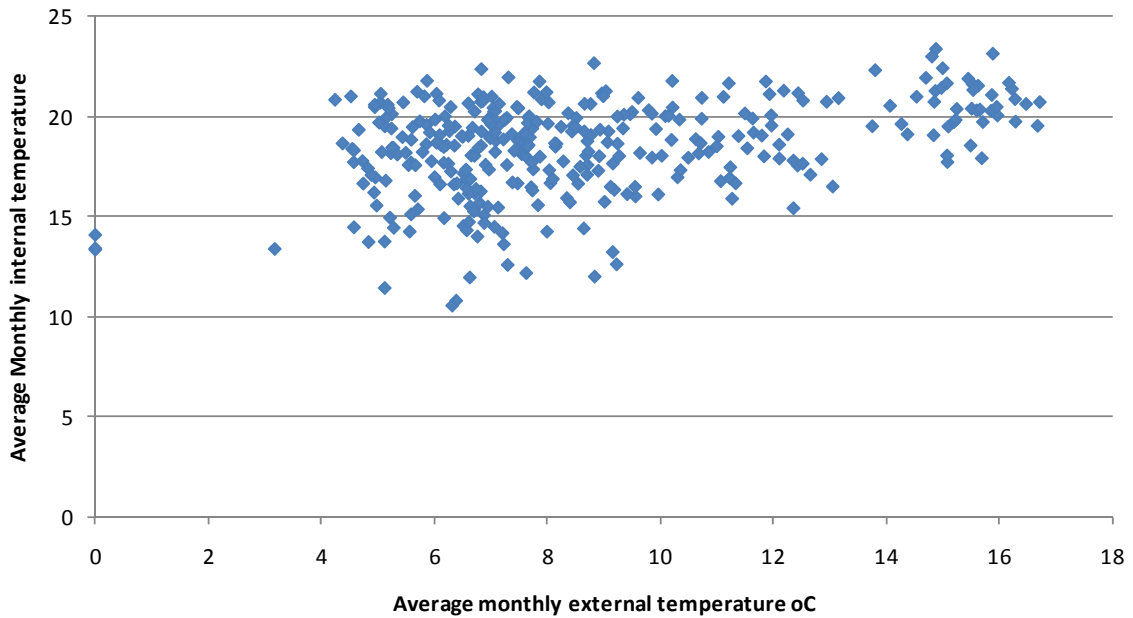
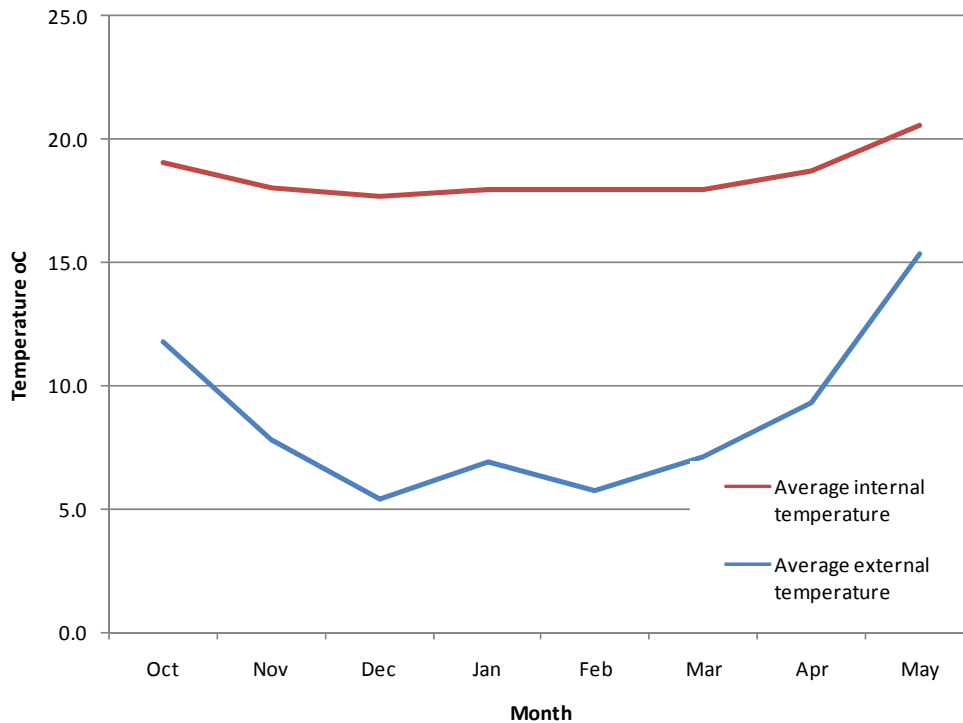


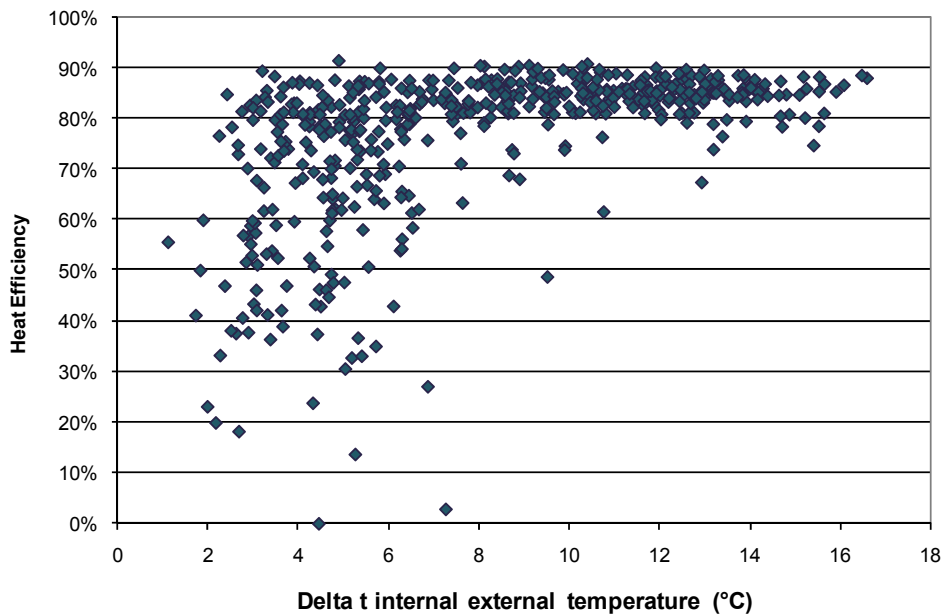
Figure 33 monthly average internal and external temperatures



When comparing the difference ( $\Delta t$ ), between internal and external temperatures (Figure 34) to heat efficiency there appears to be a weak positive correlation between  $\Delta t$  and heat efficiency but when  $\Delta t > 7^{\circ}\text{C}$  further increases in  $\Delta t$  have no observable impact on heat efficiency.

As the external temperature drops and  $\Delta t$  increases the boiler load increases, run times increase and the proportion of demand made up by domestic hot water falls. All of these factors result in an increase in observed performance and calculated efficiency.

Figure 34 Heat efficiency against monthly average  $\Delta t$  internal - external temperature



For a sample of properties, the lounge temperature (SAP zone 1) has been compared with the hall and bedroom temperatures (SAP zone 2). If this sample data set were consistent with the assumptions in the SAP methodology, we would expect that the temperatures in the lounge would be higher than elsewhere in the property.

*Figure 35 Mean variation between zone one and zone two temperature over heating season*

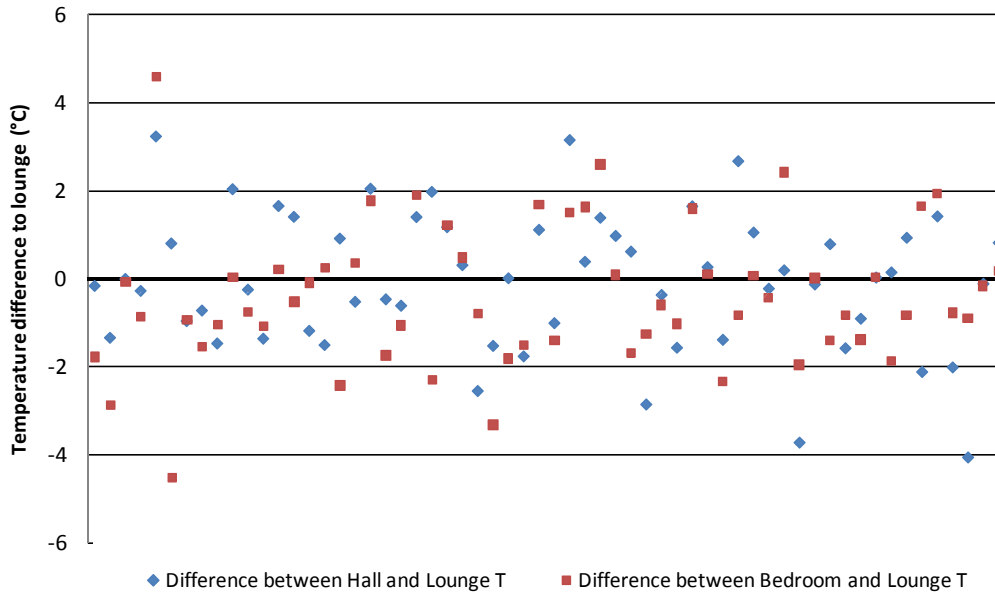


Figure 35 shows the difference in temperature between bedroom and lounge, and hallway and lounge. Data points above the x-axis indicate a lounge temperature lower than the bedroom or hallway and data points below indicate the lounge temperature is warmer than the bedroom or hallway. Although there are marginally more bedroom temperatures cooler than the lounge, Figure 35 shows no observable correlation between zone one and zone two temperatures and no observable correlation that supports the SAP assumption that zone 1 is 5°C warmer than the rest of the property. Internal temperatures vary depending on a range of factors that may include occupant preferences, controls and whether zone one doors are kept closed.

## 7.12 Secondary heating

### 7.12.1 Incidence of secondary heating use in trial properties

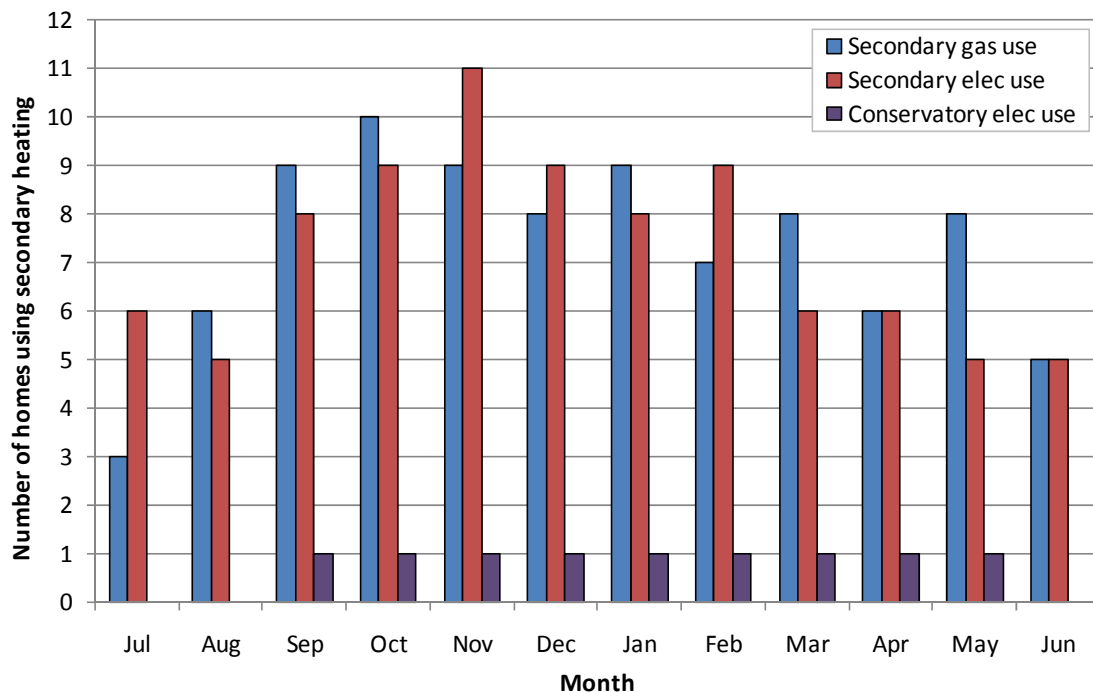
The apparent use of secondary heating is sporadic, with some sites using secondary heating appliances during the summer and winter periods and others using no secondary heating at all, even during colder months. The following analysis looks at the measurable (secondary) electric heating used and estimated gas secondary consumption converted from monitored hours of use for gas fires.

There were 47 houses within the initial trial that have a form of secondary heating monitored and operational within the property. 29 have gas fires, 15 electric and 3 solid fuel fires. The presence and type of secondary heating was not a contributory factor in the choice of trial properties. How representative the split of types of secondary heating in the trial houses is of heating types in the UK is unknown. Of the houses with secondary heating the majority of appliances that were monitored were located in the lounge (SAP zone 1). One fixed electric heater was located in a conservatory.

A number of properties had more than one form of secondary heating, either fixed or mobile. A finite number of appliances could be monitored limited by accessibility and cost. Early discussions with householders identified the most active secondary heating appliance and this was selected for monitoring. Without monitoring all secondary heating appliances within the home it is not possible to identify the exact proportion secondary heating makes up of total heat supplied and the following analysis should be considered in terms of trends.

Not all homes returning secondary heating results have also returned a full 12 months of accepted data. Of the 12 month data set of 43 sites there were 24 properties that have a form of secondary heating operational. 13 have gas fires, 11 electric. Of these houses the majority of appliances that are monitored are located in the lounge (SAP zone 1). One property, 345PYO, has a gas secondary heater monitored in the lounge as well as an electric heater monitored in the conservatory. Figure 36 shows the number of these homes using secondary heating each month. Note that 345PYO is double counted under both gas use in the lounge and electricity use in the conservatory

Figure 36 Secondary heating use by fuel type per month.

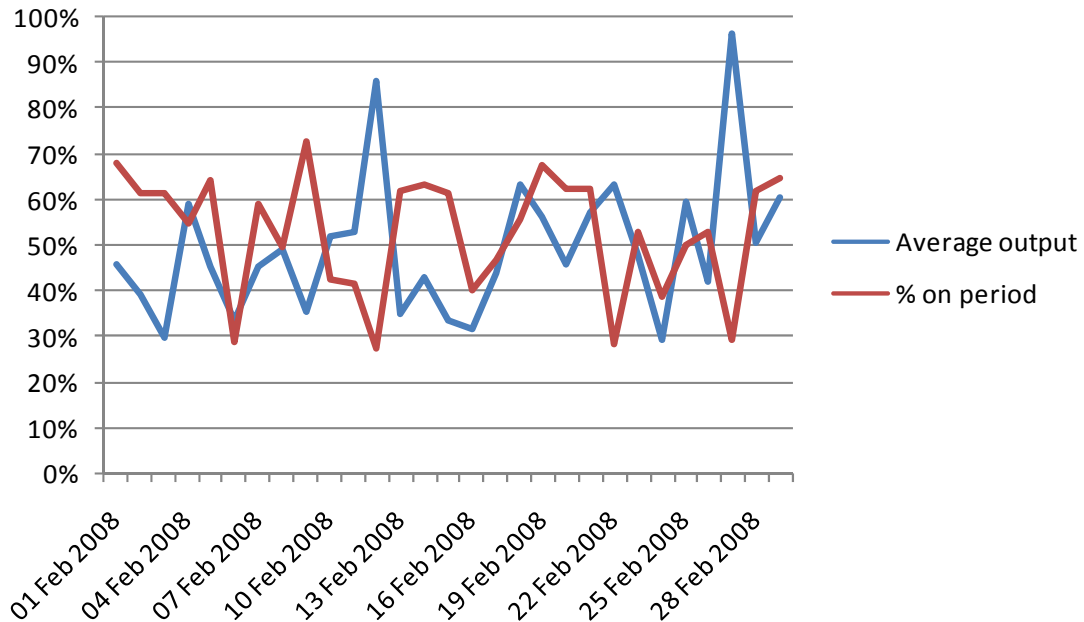


### 7.12.2 Estimation of kWh gas use from monitored hours of consumption

In the trial, gas data were collected as hours of use based on appliance flue temperature. To convert these data to kWh an estimate had to be made regarding the rated output of each appliance over the operating period. Calculated kilowatt-hours consumed were based on the assumption that on average gas fires are used at full rating for 30% of the operating time and at 25% of their full rating for 70% of the operating time. This equates to a 50% output for the majority of the “on” period. This assumption is based on anecdotal evidence from householders and from data

collected in the field. Figure 37 shows the percentage output of a gas fire in property 320ETH. It can be seen that although usage fluctuates depending on day and thus external temperatures, the fire is used at approximately 50% output during operation.

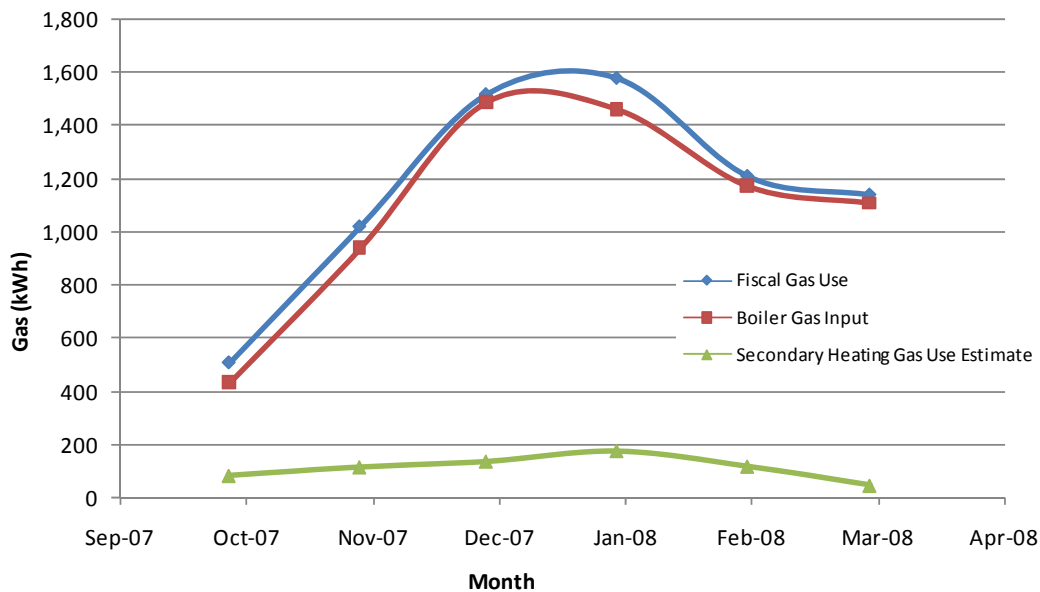
Figure 37 Percentage output of gas fire in 320ETH



The following figures show the estimated consumption of gas in the secondary appliance in comparison to whole house and boiler use in a selection of properties. As stated above, the figures used are based on the assumption that the gas fire is used at full rating for 30% of the operating time and at 25% of its rating for 70% of the operating time. The fiscal data is taken from monthly householder meter readings (further described in section 7.16).

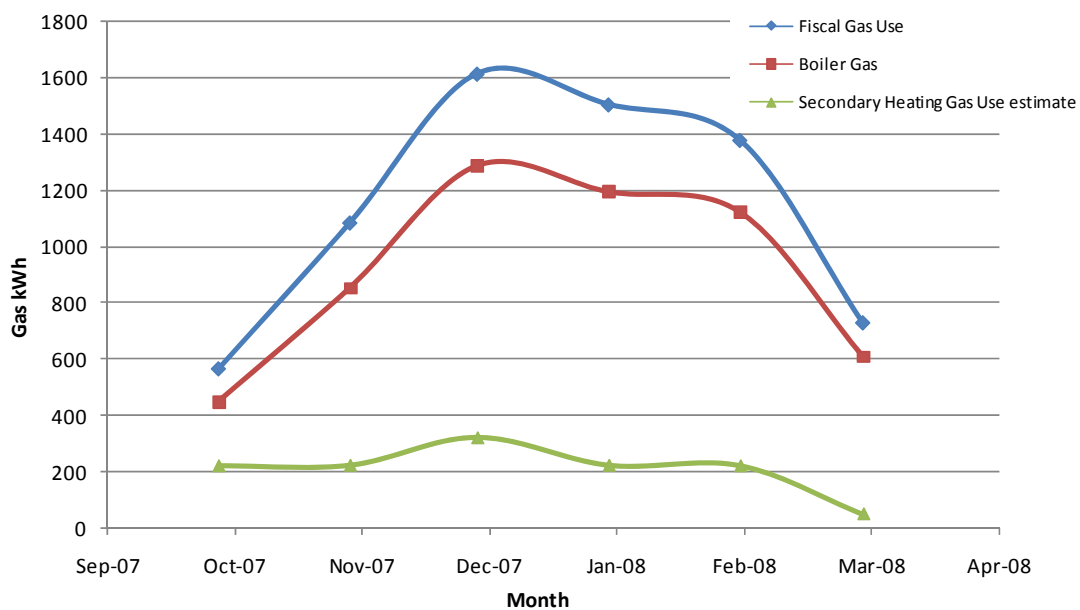


**Figure 38: Property 326ABR - monthly whole house, boiler and secondary appliance gas consumption.**



Both figures show good correlation between fiscal gas, boiler gas and estimated secondary gas consumption; with the peaks in fiscal gas use matching the peaks in space heating as would be expected. Property 345PYO shows a consistently higher use of secondary heating than 326ABR, with the gas fire used consistently throughout the winter period totalling 1269kWh of gas consumption in contrast to 314kWh at 326ABR. Conversely the boiler gas at 326ABR (6590kWh) is greater than at 345PYO (5504kWh), almost following the fiscal meter consumption. The fiscal meter consumption however is relatively similar for both properties totalling 6967kWh at 326ABR and 6859kWh at 345PYO for the heating season.

**Figure 39 Monthly whole house, boiler and secondary appliance gas consumption. Property 345PYO.**



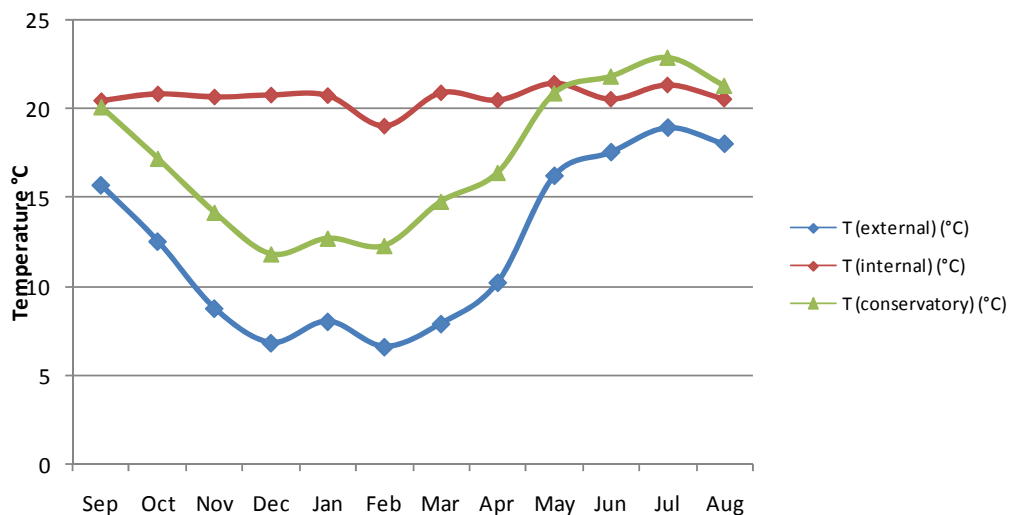
Site survey data do not currently contain a power rating for all operational gas fires. Ratings were collected either from the actual appliances during site surveys or subsequently from the manufacturers. There are a number of appliances which did not display their power rating and for which manufacturer's data are difficult to obtain. Analysis of secondary heating includes data from 6 secondary gas fires with known appliance ratings from homes with a year's data. Data from 7 further secondary gas fires are awaiting conversion based on the identification of the appliance ratings. Trial properties are currently being revisited to fit chrono-proportional controls for the next stage of the field trials. During these visits GaC are reviewing gas appliances to attempt to determine appliance ratings.

### 7.12.3 Conservatory heating

14 of the 60 trial houses featured conservatories. Surveys of householders indicated that 12 of these properties featured some form of electric heating (including oil filled and convector heaters). The Energy Saving Trust decided to monitor the conservatory temperatures in 10 households to identify which were being heated and to collect data on heating patterns. Of the 10 monitored conservatories 8 were associated with properties that provided 12 consecutive months of accepted data.

In 6 of the monitored conservatories (75% of data set), monthly average temperatures tracked external average temperatures, at between 2 and 5°C warmer (probably due to daytime solar gain). Figure 40 shows an annual temperature plot on one property 316MBA where conservatory temperature can be seen to track external temperature.

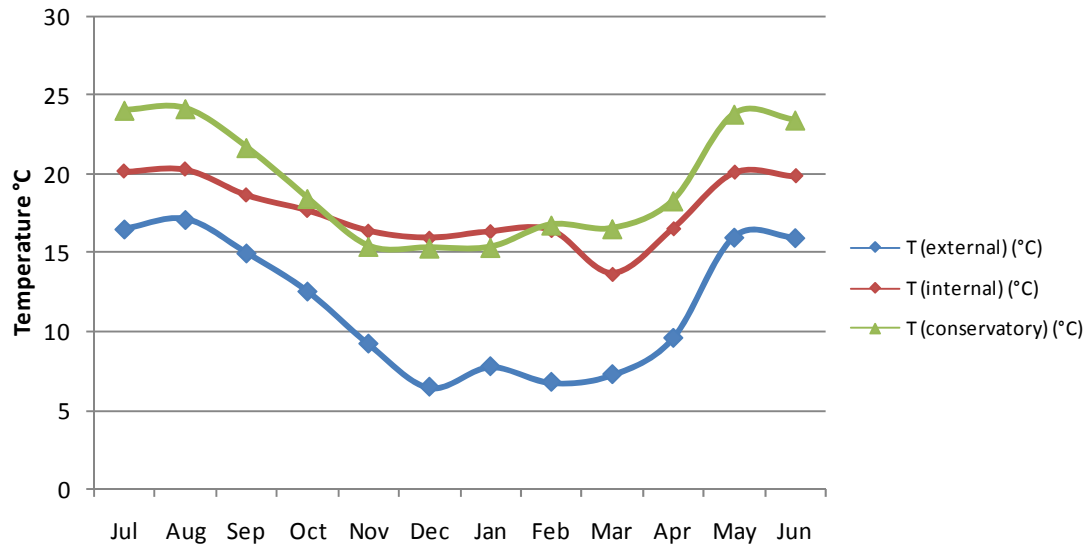
Figure 40 - 316MBA – Conservatory Temperature tracks external temperature



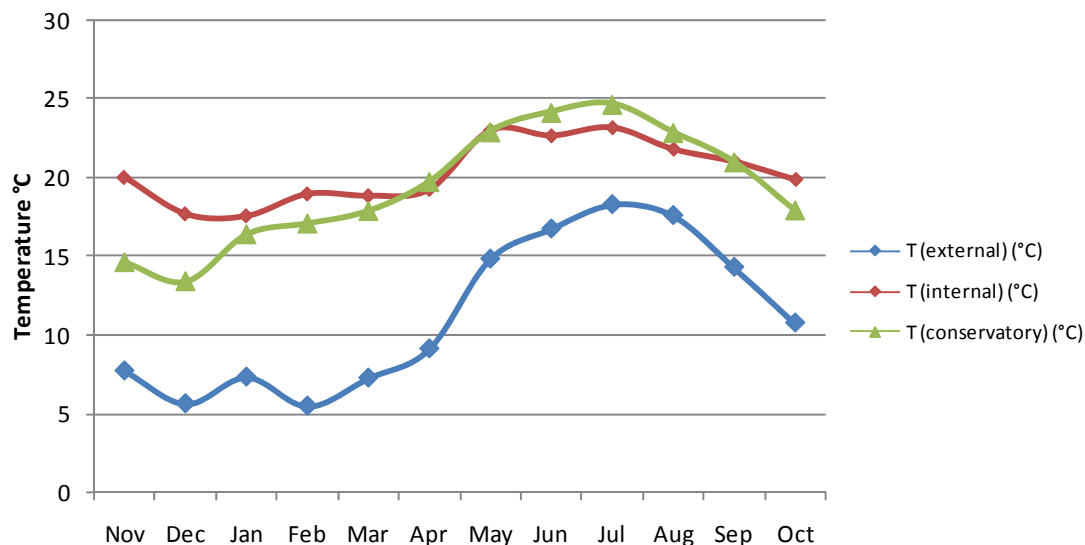
In the other two monitored conservatories (25%) it was observed that average conservatory temperature tracked the average internal temperature throughout the winter. One property, 345PYO, featured an electric heater in the conservatory which is discussed further below, the other 321THB does not have reported secondary heating from the monitored data indicating that either the door between conservatory

and house is left open or there is a mobile heater in the conservatory that is not monitored.

Figure 41 – 345 PYO – Conservatory temperature tracks internal temperature – secondary heating recorded



**Figure 42 – 321THB – Conservatory temperature tracks internal temperature – no secondary heating recorded**



**7.12.4 Analysis of secondary heating usage in trial data set**

Table 16 summarises the incidence of secondary heating usage within the 43 boilers of the accepted dataset. Additional properties have secondary heating installed and monitored but were either not operational during the trial period or have not provided any valid data sets.

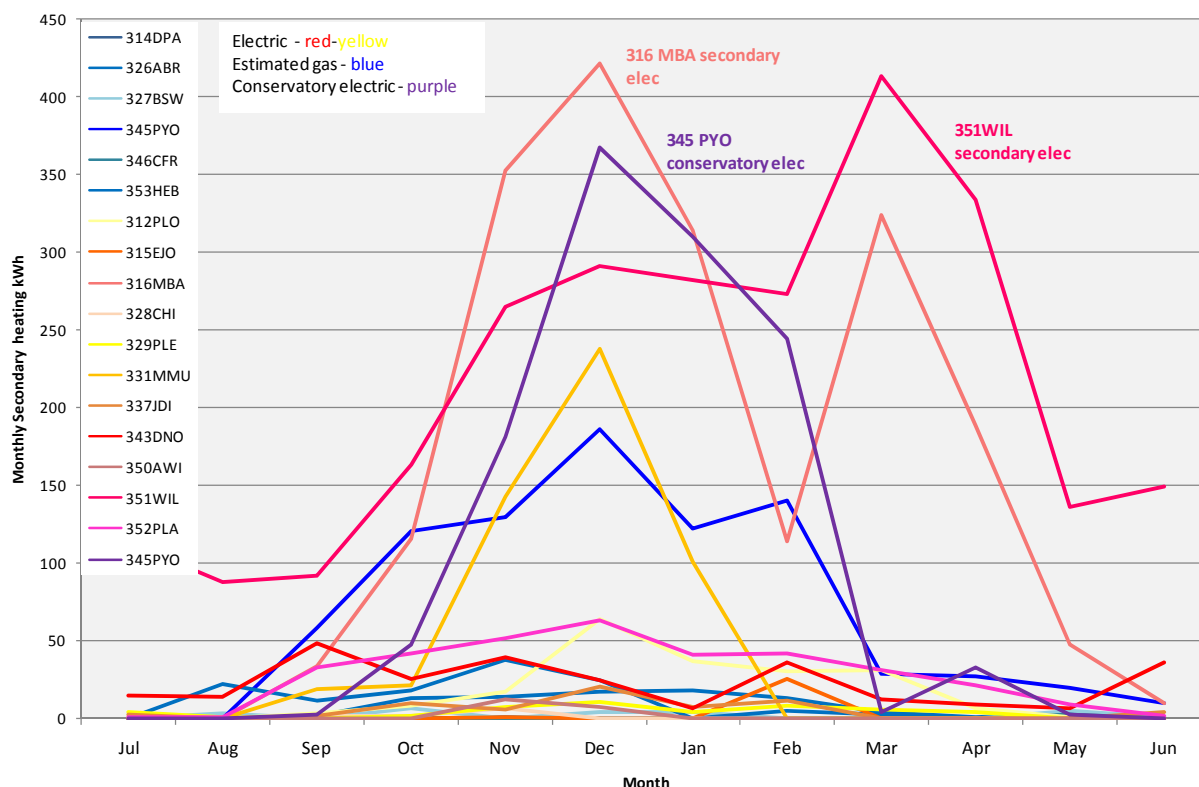
*Table 16 Summary of secondary heating in 12 month data set*

Electric secondary heating	electric secondary heating in conservatory	Gas secondary heating with appliance rating*	Gas secondary heating with no appliance rating	Sum gas secondary heating*	No secondary heating
11	1	6	7	13	19
25.6%	2.3%	14.0%	16.3%	30.2%	44.2%

Figure 43 shows one year’s consumption of gas and electric secondary heating plotted on a monthly basis. Fuel types are plotted in different colours – warm colours (red to yellow) for electric heating, cold colours (blues) for gas and purple for conservatory electric heating. As would be expected, there is a general increase in consumption over the winter months. Usage is generally low with only four properties indicating usage above 100kWh/month over the year. Two properties, 316MBA and 351WIL show additional peaks in use of secondary heating in March.

Notably, the conservatory, 345PYO, was heated throughout the heating period and usage remains high from November to February, peaking in December.

Figure 43 Annual plot of secondary heating consumption within trial properties



### 7.12.5 Comparison of proportion of secondary heating with Part L1A stipulation

Approved document L1A requires that when calculating the Dwelling Emission Rate (DER) 'it shall be assumed that a secondary heating appliance meets part of the space heat demand. The fraction provided by the secondary heating system shall be as defined by SAP2005...' Part L1A states that if no secondary heating appliance is specified an electric room heater should be assumed.

One key objective of the condensing boiler field trials is to understand what proportion of total space heating is supplied by secondary appliances and to compare this to the Part L1A stipulation. For a gas primary heating system SAP2005 assumes that secondary heating will account for 10% of the total delivered space heat. Annual data from the sites returning secondary heating data indicate that secondary heating use is generally low, on average accounting for approximately 4.1% of the total space heating supplied to a dwelling (Figure 45).

Proportionally the highest consumption is from an electric heater situated in the conservatory of 345PYO, used throughout the coldest months of 2008 (in addition to a gas heater located in the lounge). If this conservatory is isolated from the dataset then the recalculated average secondary heating accounted for 3.6% of total space heating supplied.

In 11 of the sites returning secondary heating data, secondary heating accounts for less than 5% of the space heating demand (Figure 44). If the gas fire and

conservatory electric heater used in property 345PYO are combined then secondary heating would account for 30% of heating demand in the property.

*Figure 44 Banded results for annual secondary electric heating and estimated secondary gas heating as percentage of annual space heating demand*

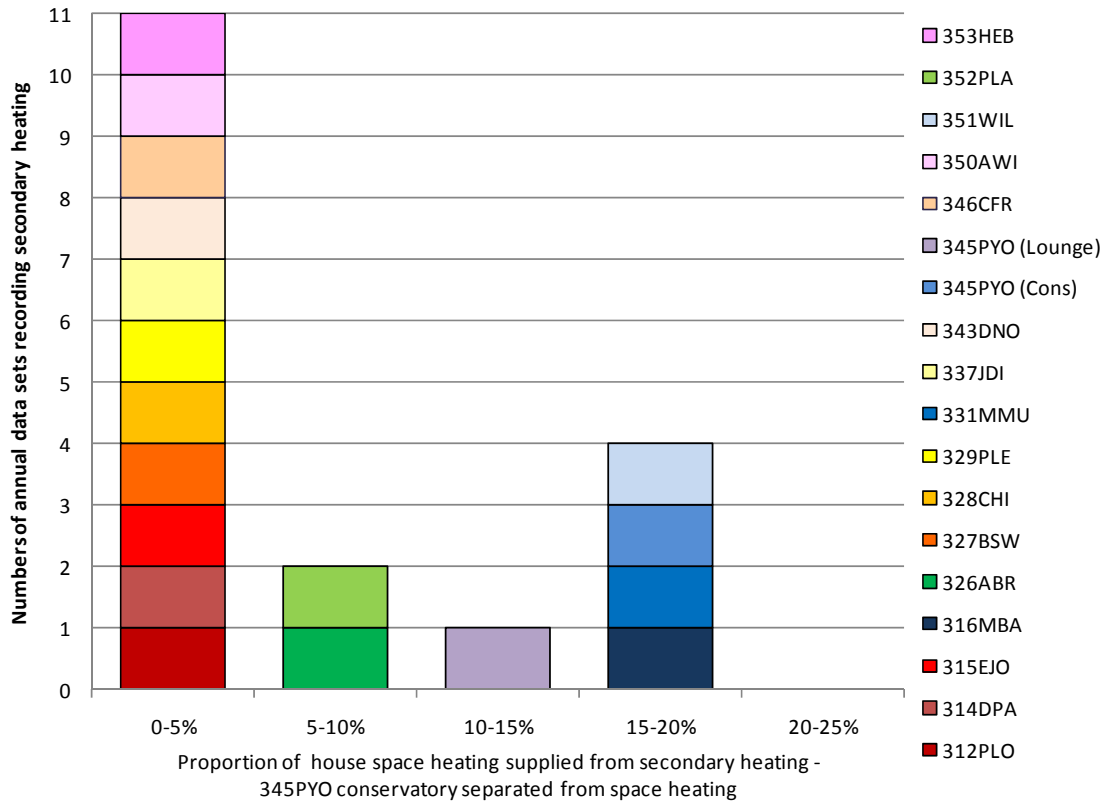
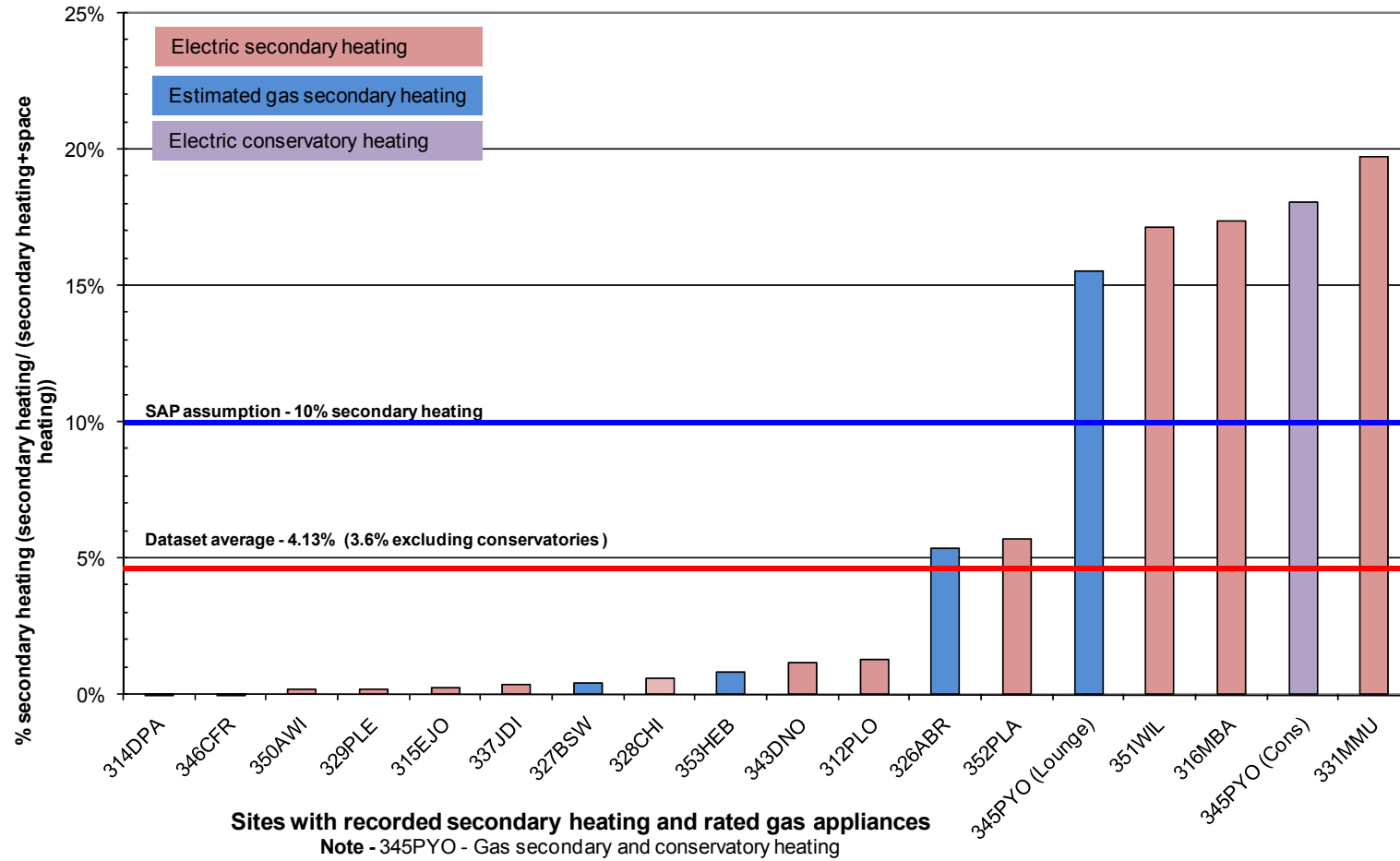


Figure 45 Annual secondary electric heating and estimated secondary gas heating as percentage of annual space heating demand



### 7.13 Heating patterns for central heating - modes of operation

The graphs below show the daily profiles for two combination and two regular boilers operating during a 24 hr period on a weekday (Thursday 17<sup>th</sup> January) and at the weekend (Sunday 20<sup>th</sup> January 2008). Boilers were selected to offer both poor performance (efficiency~80%) and good performance (~90% efficiency). Operating regimes are compared to those used in the BREDEM 12 model.

These graphs represent a very small sample of boilers and days monitored and as such cannot be taken to be representative of the trial group. It is possible to suggest however, that although the BREDEM 12 model does apply to some properties, each householder applies their own decision on how best to heat their house, which may or may not be the most effective/efficient.

#### 7.13.1 BREDEM 12 - modes of operation – week and weekend

Figure 46 BREDEM 12 Weekly heating pattern

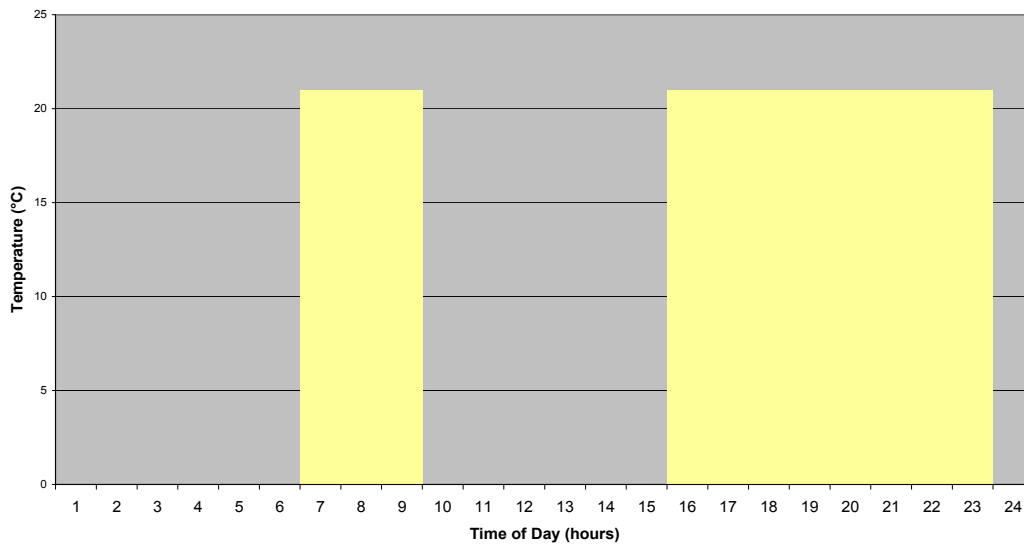
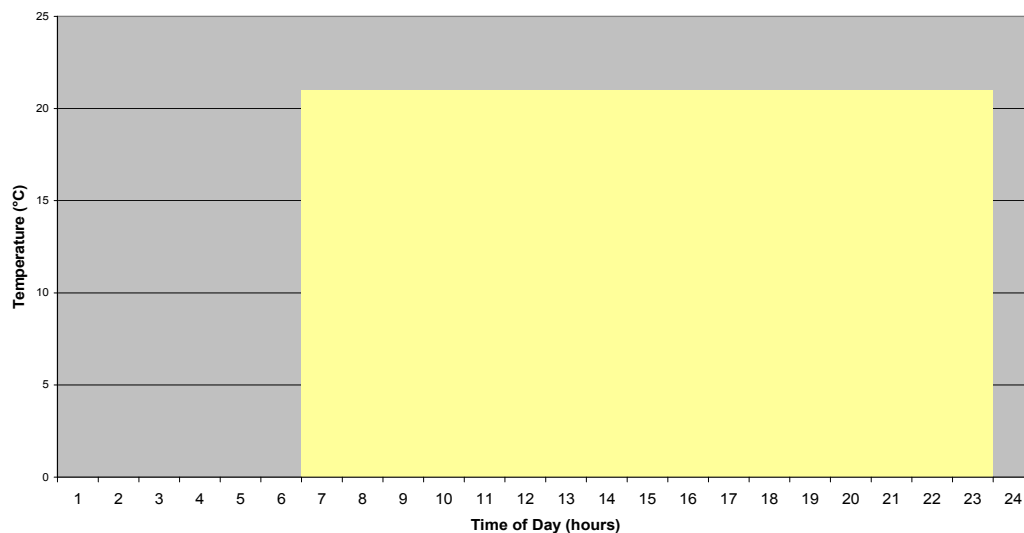


Figure 47 BREDEM 12 Weekend heating pattern





### 7.13.2 Combination Boiler - modes of operation - 356MJM

Figure 48: 356MJM – Flow, return and heat meter readings Thursday 17<sup>th</sup> Jan 08

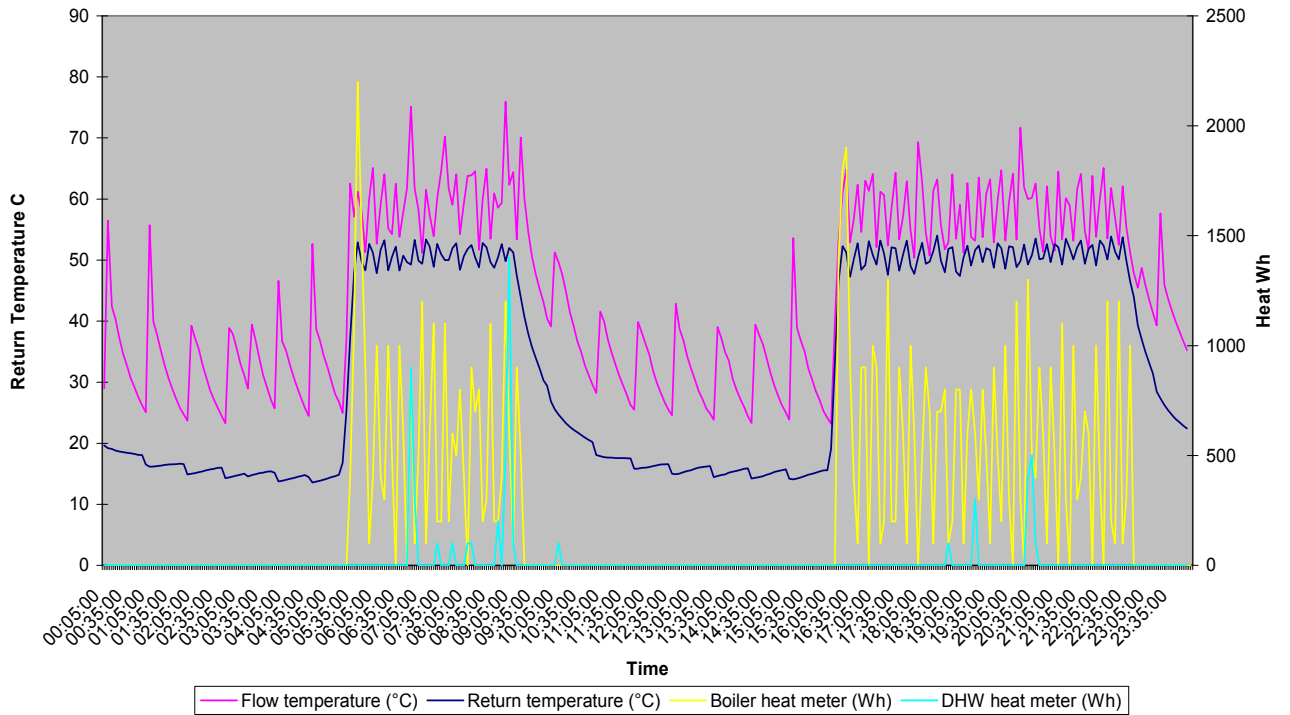
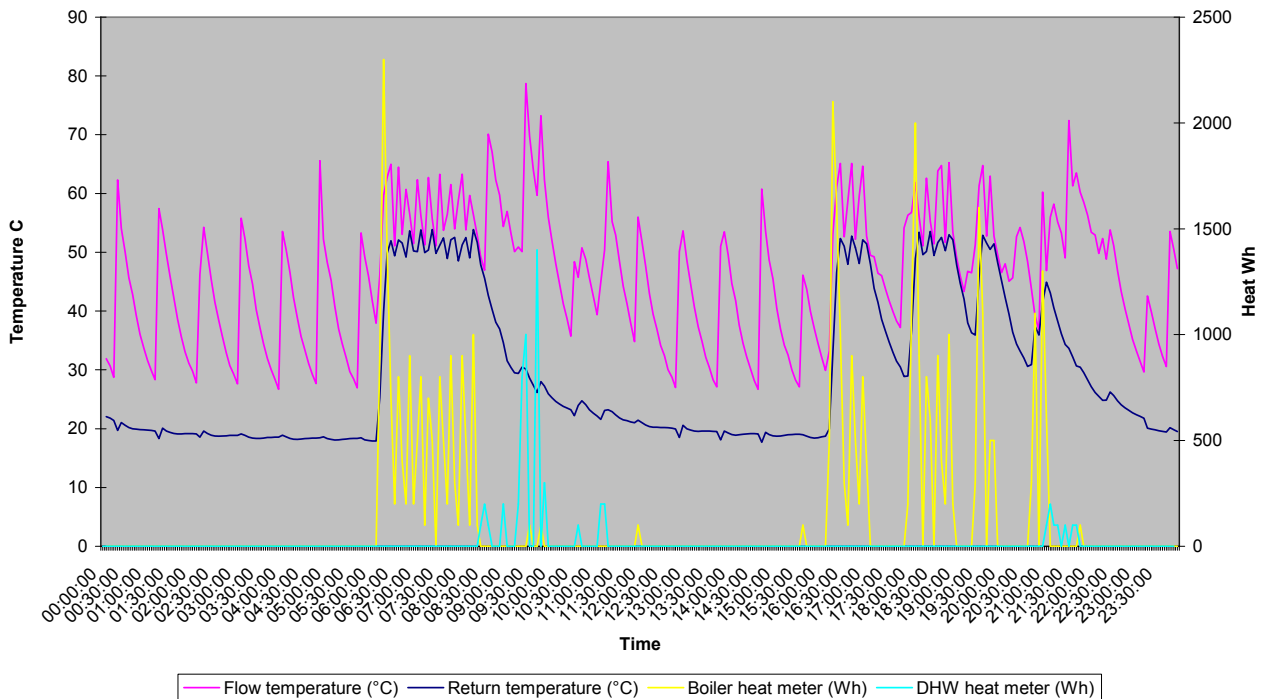


Figure 49: 356MJM – Flow, return and heat meter readings Sunday 20<sup>th</sup> Jan 08

### 7.13.3



### Combination Boiler - modes of operation – 310MPO

Figure 50 310MPO – Flow, return and heat meter readings Thursday 17<sup>th</sup> Jan 08

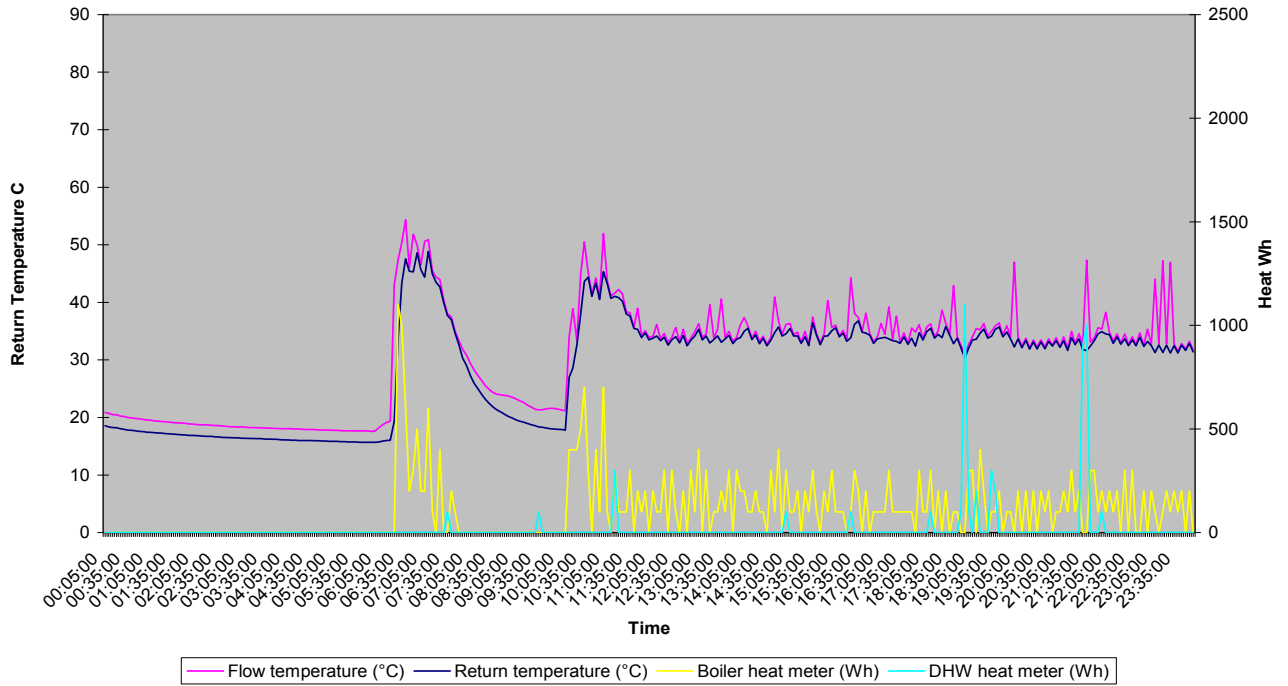
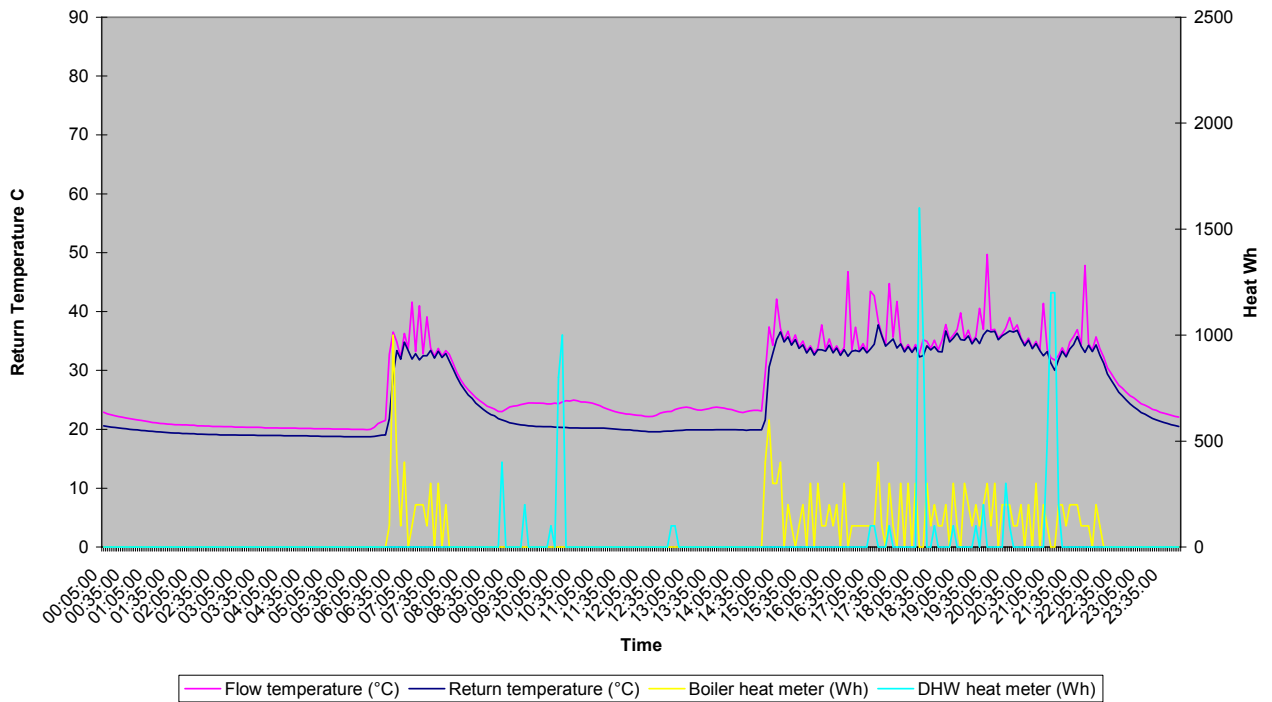


Figure 51 310MPO – Flow, return and heat meter readings Sunday 20<sup>th</sup> Jan 08



Comparing the two sample days across the two sites, the heating pattern employed at 356MJM correlates well with the bi-modal operation suggested by BREDEM 12 (Figure 43). This continues weekday to weekend although the timings of boiler operation and heat production are slightly later on the weekend (weekday mornings heat is provided from 05.30am, on weekends this changes to 06.30am) Evening operation remains the same. 310MPO can also be seen to be operating bi modally although with a longer weekday heating period than weekend.

### 7.13.4 Regular boiler - modes of operation – 346 CFR (88% trial efficiency)

Figure 52: 346CFR - Flow, return and heat meter readings Thursday 3<sup>rd</sup> Jan 08

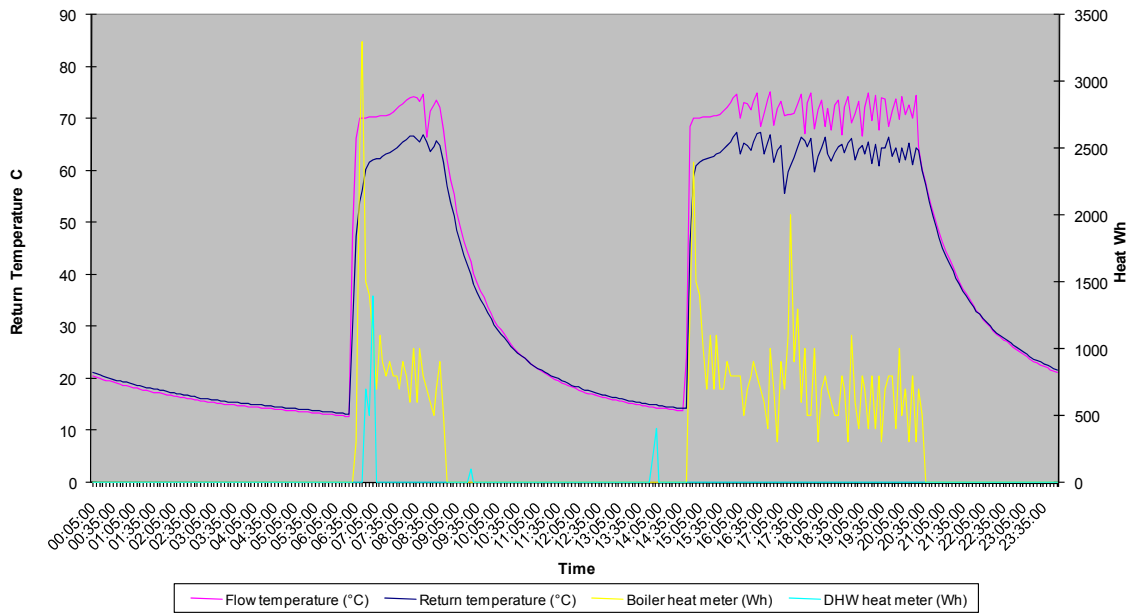
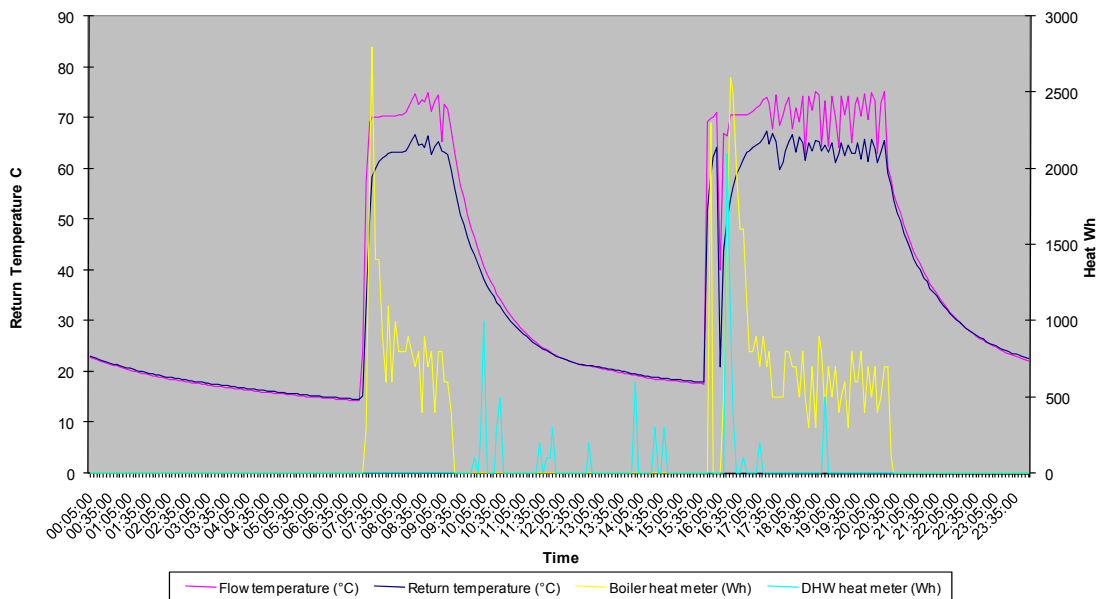


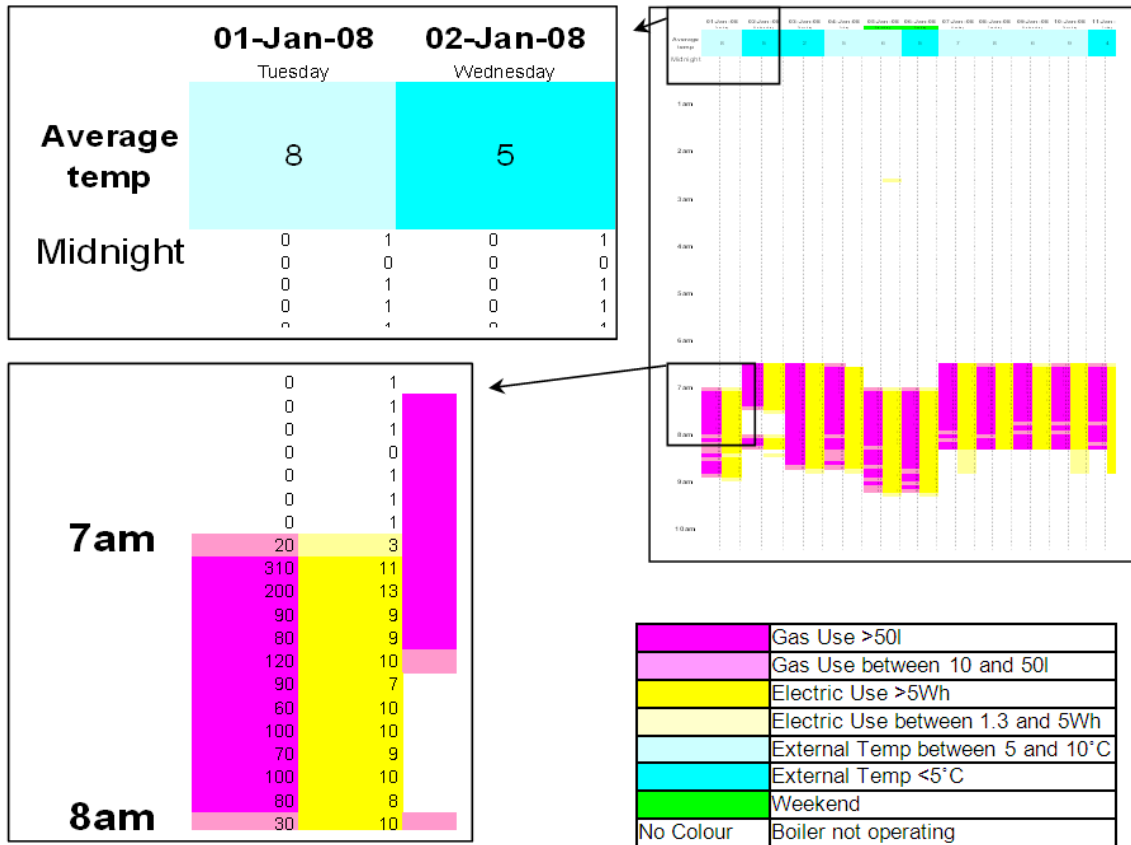
Figure 53: 346CFR - Flow, return and heat meter readings Sunday 6<sup>th</sup> Jan 08



Property 346CFR has virtually identical heating patterns on weekdays and weekends, using the same bi-modal heating pattern (weekday 06.30am to 08.45am and 14.45pm to 20.30pm, weekend days 07.00am to 09.15am and 15.30pm to 20.30pm).

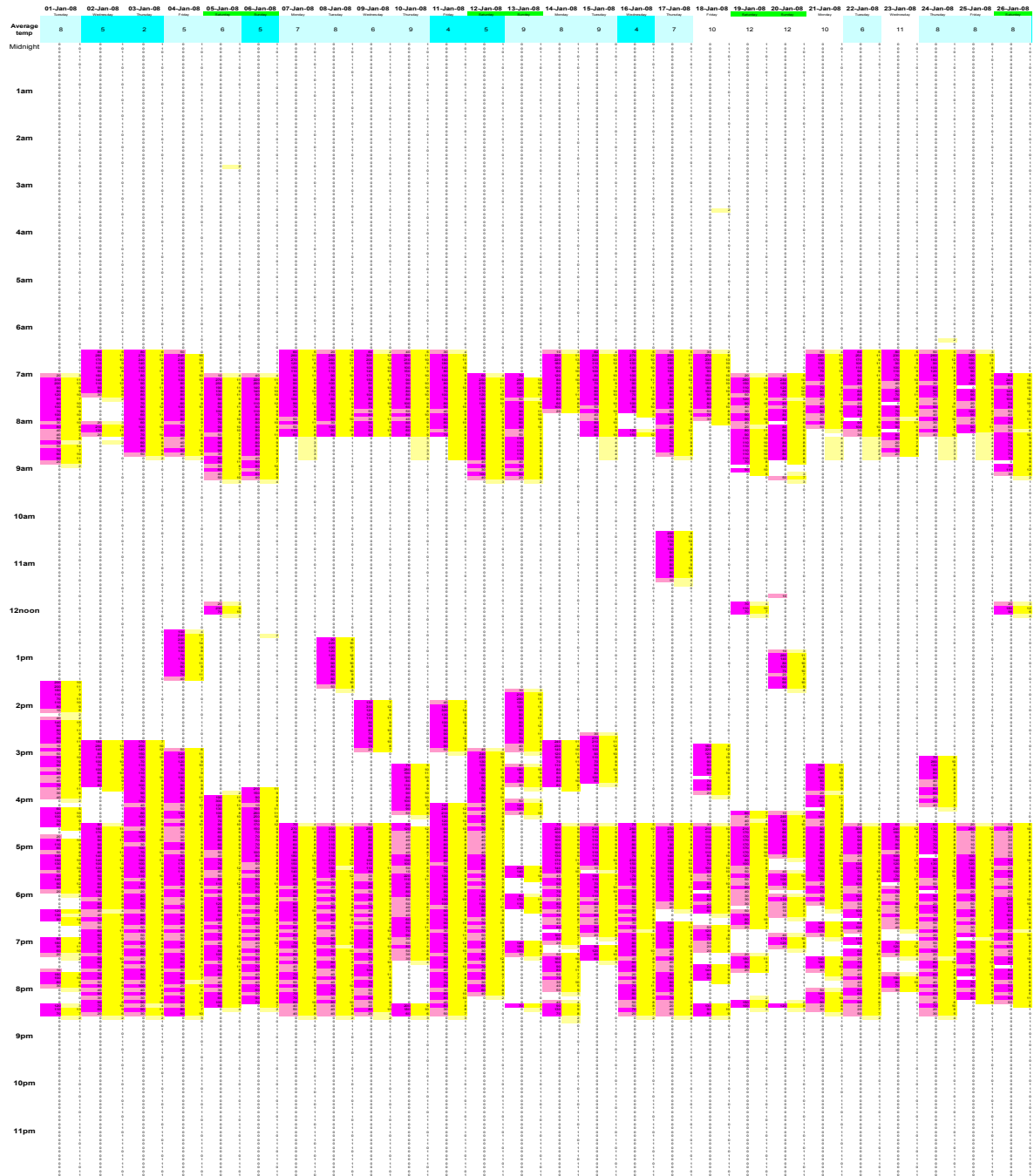
An alternative representation of the mode of heating operation is a 'Tapestry' graph as shown overleaf in Figure 55 and explained below in Figure 54. Whilst initially potentially confusing, this representation portrays a whole month's data at 5 minute intervals on one page and as such is extremely useful. Figure 54 enlarges two sections of a tapestry the show individual data points. In the tapestry days are measured on the x axis, with each day featuring two columns of data, and time is measured down the Y axis from 00:05h to 12:00h. Each 5min data record is colour coded according to value. Pink boxes indicate gas use (dark pink>50l, light pink 10-50l) and yellow boxes indicate electric use (dark yellow>5Wh, light yellow between 1.3 and 5Wh). At the top of the tapestry blue indicates temperature with the turquoise indicating external temperatures below 5°C. Green bars indicate a weekend.

Figure 54: Explanation of tapestry representation of data



The GaC monthly plot of 5minute data for 346CFR (Figure 55) shows a consistent bimodal heating pattern across the month with occasional use of the boiler for an hour or two during the day.

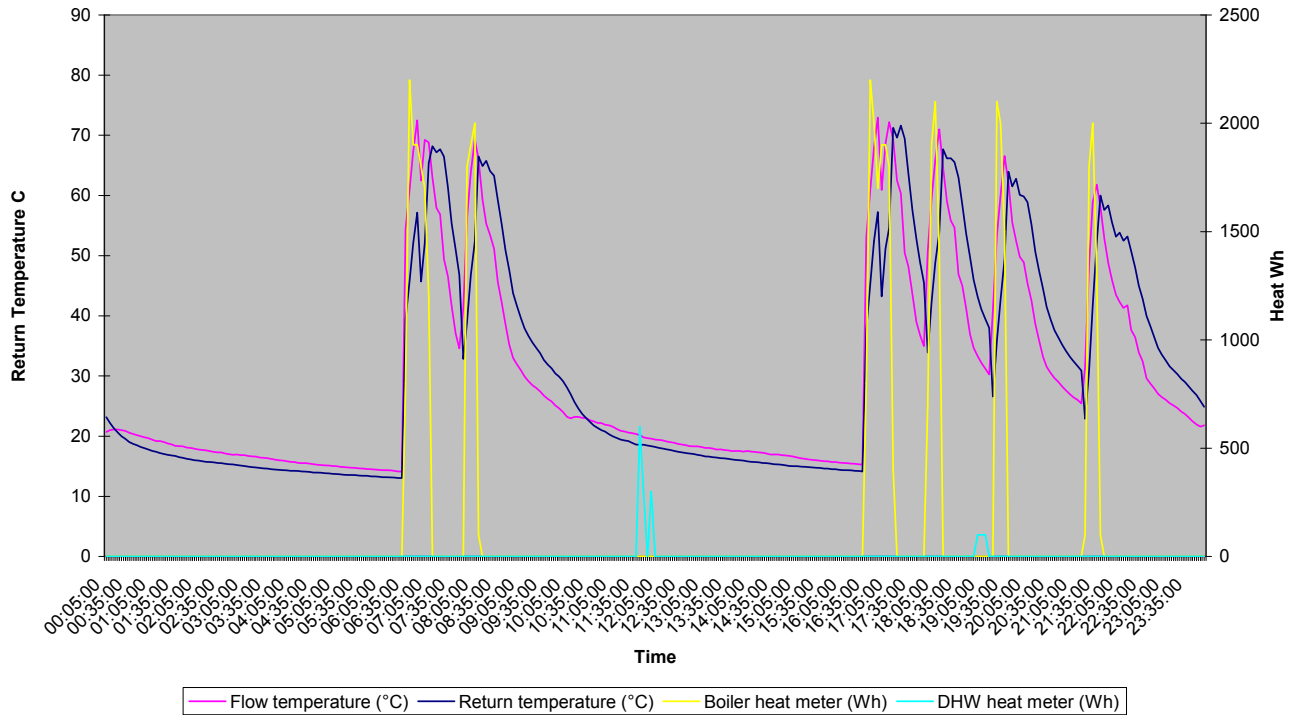
Figure 55 346CFR - Flow, return and heat meter readings January 08



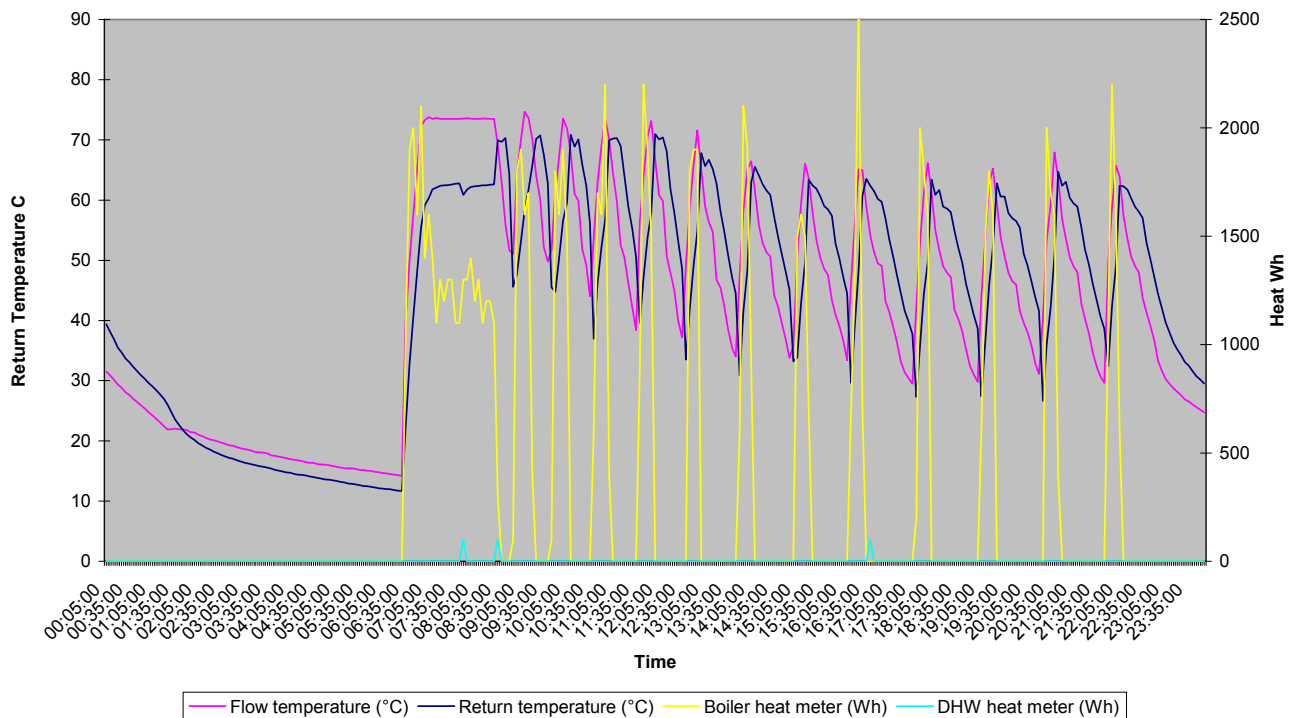
	Gas Use >50l
	Gas Use between 10 and 50l
	Electric Use >5Wh
	Electric Use between 1.3 and 5Wh
	External Temp between 5 and 10°C
	External Temp <5°C
	Weekend
	Boiler not operating

**7.13.5 Regular boiler - modes of operation – 336JON (~81% efficient)**

*Figure 56: 336 JON – Flow, return and heat meter readings Thursday 17<sup>th</sup> Jan 08*



*Figure 57 336JON – Flow, return and heat meter readings Sunday 20<sup>th</sup> Jan 08*



Property 336JON follows the BREDEM 12 model well. It has bi-modal operation on weekdays and uni-modal operation on the weekends. It must be noted however the amount of cycling that takes place over the Sunday period of operation which could impact on the overall heat efficiency of the boiler (boiler operating ~81% efficiency).

## 7.14 System controls

Given the growing interest in system controls, GaC have reviewed the actual control mechanism being followed by 4 houses in the condensing boiler trial. The standard UK control strategy as hypothesised within SAP is that:

- The boiler is correctly sized, i.e. is typically (25 to 29 X heat loss coefficient) kW, plus if a system boiler, an allowance of 2kW for DHW.
- The heating period is controlled bi-modally (7-9am and 4-11pm Mon-Fri and 7am-1pm Sat and Sun)
- Rooms have radiators sized to room heat loss.
- The boiler and pump are switched ON and OFF using a room thermostat (typically in the hall or living room) set to about 21C. This room does not have TRVs.
- Other radiators have TRVs enabling optimisation of each room.

In practice, most combination condensing boilers now have modulating control based upon water flow temperature. When the boiler thermostat calls for heat, the boiler purges, ignites at an appropriate gas rate (which varies from appliance to appliance, but is usually significantly above minimum turndown) and then turns down before modulating (either up or down) depending upon the offset from the boiler set point. If this is only modest the boiler will quickly turndown and then continue to turndown further, until as the offset approaches zero, the boiler turns off. Theoretically the room thermostat switches off the boiler when the property is at the desired temperature, thereby saving pump electricity and stopping the boiler cycling upon its boiler thermostat.

In practice the following can occur:

- Clock set to incorrect times.
- TRVs set so low or room thermostat so high that room thermostat is never satisfied.
- Very rapid boiler cycling due to low loads/low water pumping rates due to TRVs.

It is principally to reduce this problem that boiler makers have introduced minimum cycle timers and high levels of modulation. The latter also increase efficiency as some combi boilers will barely condense at full output even at a water return temperature of 30C (i.e. traditionally considered 'condensing operation').

The first two of the above list cause pump (and hence boiler) to operate apparently an 'excessive' number of hours per year, although depending upon model, the boiler may turn down sufficiently to offset this. This is a complex optimisation as (to a certain extent) the improved efficiency of operating at high levels of turndown will offset the additional pumping and boiler fan energy.

This data is presented graphically below. This shows in 2 colours (Gas = Pink, Electricity = Yellow) the firing cycles of boilers from the perspective of gas and electricity rates. A blank cell indicates no firing and darker colours represent increasing gas or electricity consumption.

Property 323RWA: Boiler fires continually. It is regulated by TRVs and boiler thermostat as boiler modulates down as heat requirement is satisfied. (Fig 54)

Property 312PLO: Bimodal boiler operation. Boiler fires at maximum for the majority of the “on” period and does not modulate down. Regular cycling shows boiler is controlled on room thermostat thus boiler and pump are switched off as temperature requirement is met. (Fig 55)

Property 346CFR: Also on bimodal time clock control but the house never reaches the required temperature so the boiler operates at maximum output for the majority of the “on” period. Very little cycling or modulation observed. Sometimes under room thermostat control a boiler can operate continuously. This can arise if the hall temperature is affected by or even dominated by the temperature of adjacent rooms. If the hall is dominated by a ‘cold’ kitchen it may never switch off, if it is dominated by a ‘hot’ living room it may cycle. (Fig 56)

Property 315EJO: Uni-modal boiler operation. Regular cycling shows room thermostat control, however pump runs continually suggesting the boiler interlock is not operational. (Fig 57)

Key

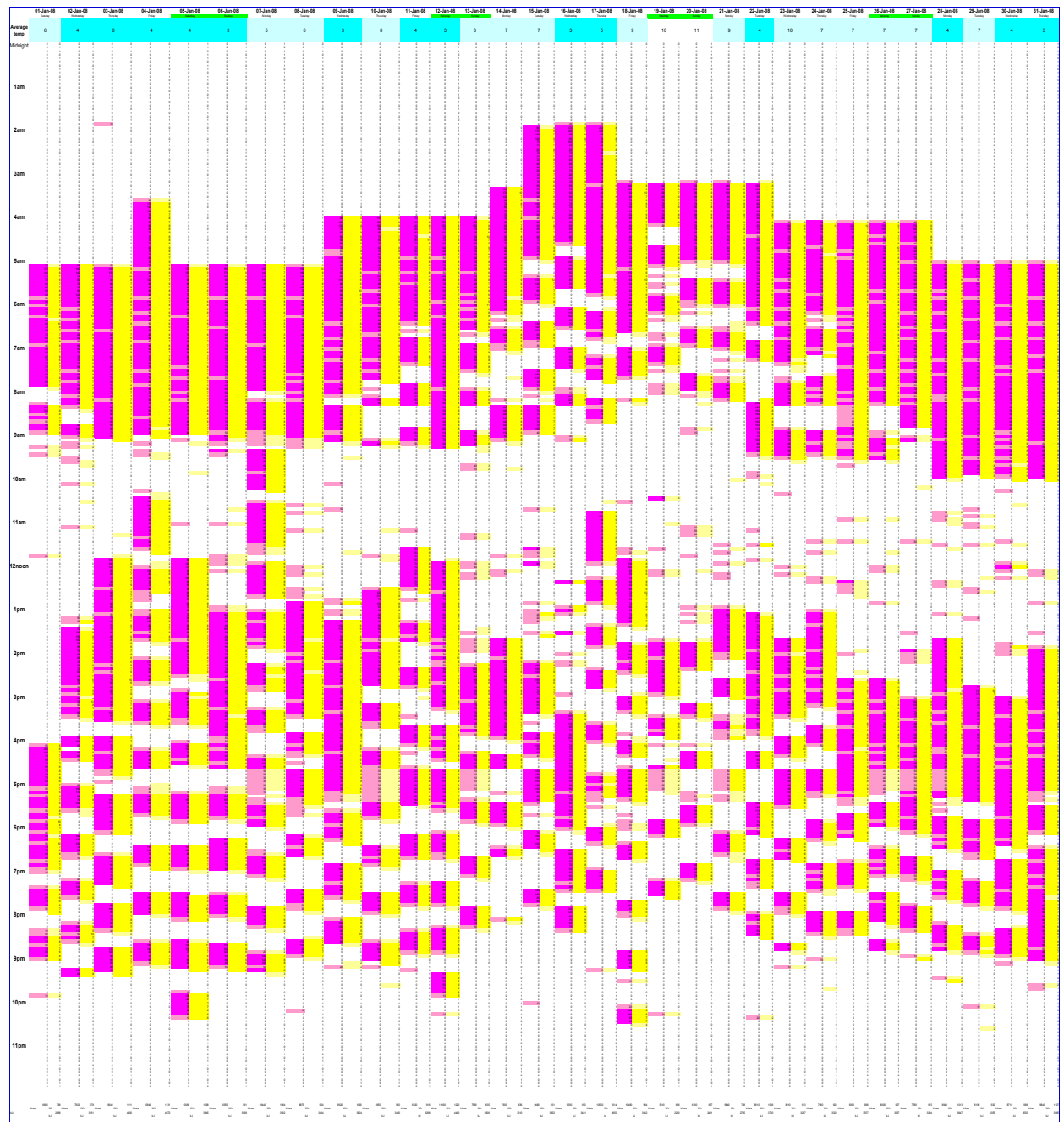
	Gas Use >50l
	Gas Use between 10 and 50l
	Electric Use >5Wh
	Electric Use between 1.3 and 5Wh
	External Temp between 5 and 10°C
	External Temp <5°C
	Weekend
	Boiler not operating



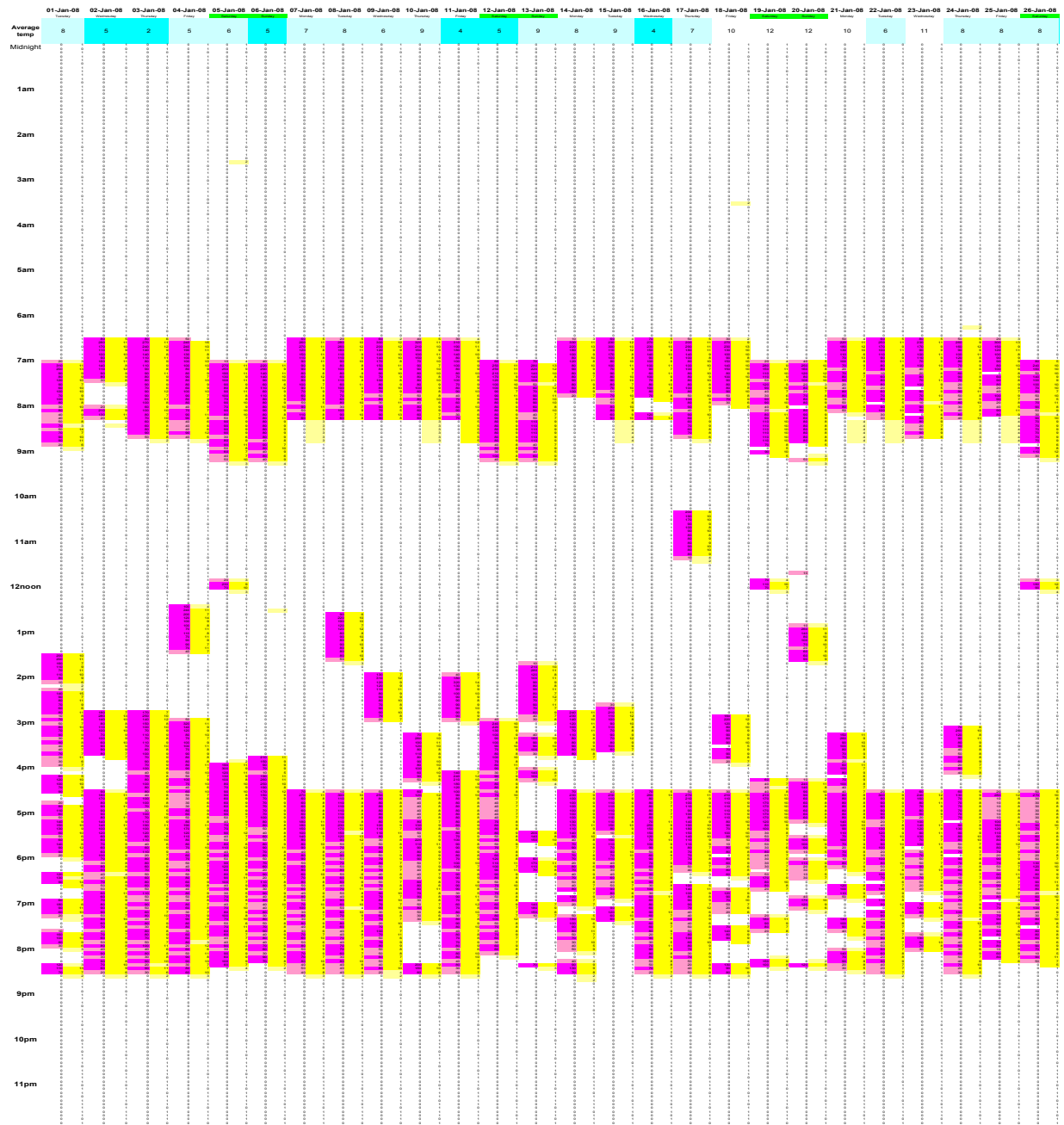
Figure 58:323RWA, January 2008



Gas Use >50l
Gas Use between 10 and 50l
Electric Use >5Wh
Electric Use between 1.3 and 5Wh
External Temp between 5 and 10°C
External Temp <5°C
Weekend
No Colour

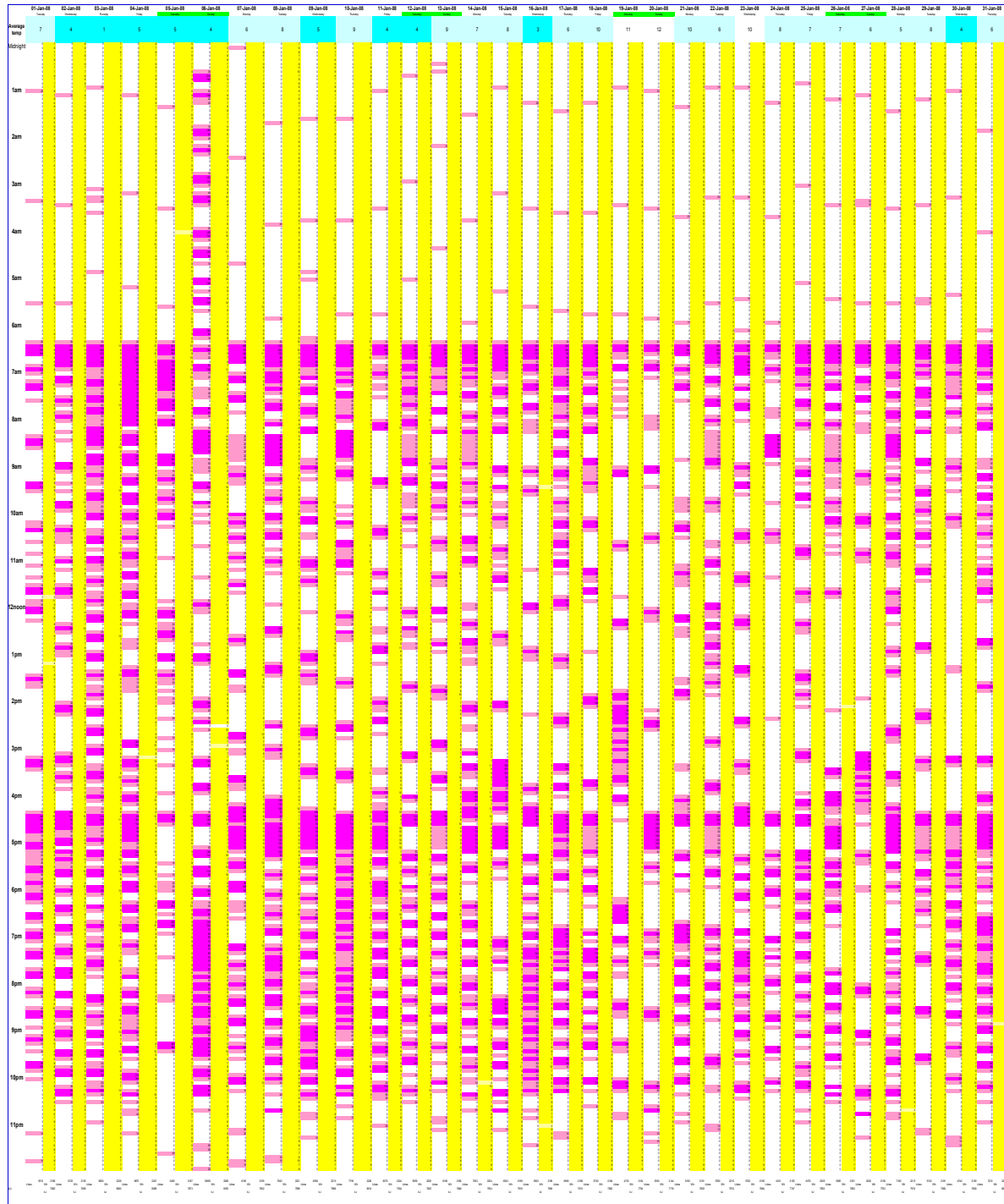


	Gas Use >50l
	Gas Use between 10 and 50l
	Electric Use >5Wh
	Electric Use between 1.3 and 5Wh
	External Temp between 5 and 10°C
	External Temp <5°C
	Weekend
	Boiler not operating



	Gas Use >50l
	Gas Use between 10 and 50l
	Electric Use >5Wh
	Electric Use between 1.3 and 5Wh
	External Temp between 5 and 10°C
	External Temp <5°C
	Weekend
	Boiler not operating

Figure 61:315EJO, January 2008



	Gas Use >50l
	Gas Use between 10 and 50l
	Electric Use >5Wh
	Electric Use between 1.3 and 5Wh
	External Temp between 5 and 10°C
	External Temp <5°C
	Weekend
	Boiler not operating

## 7.15 Levels of boiler control

There are a range of control strategies within the trial including time clock/programmer, TRVs, room thermostats or a combination of all these. However people do not live in their houses in the same way. Some have very well controlled systems, others open windows when the heating is operational. Furthermore installation and placement of controls can vary and this will impact on perceived level of control for reasons outside the control of the householder.

By plotting the gas used by the boiler against the delta T of internal and external temperatures, the consistency of control can be decided by how close a fit the data points are to the line of best fit, ( $R^2$  value (coefficient of determination) used to show "goodness of fit"). The levels of control can be divided into 3 categories:

- Very good control:  $R^2$  value of 0.9 or greater
- Reasonable control:  $R^2$  value 0.7 to 0.9
- Inconsistent lifestyle, poor placement or poor quality of controls:  $R^2$  value less than 0.7

The following figures show the result of these data plots.

Figure 62 Properties in which good boiler control is observed;  $R^2$  value 0.9 or greater.

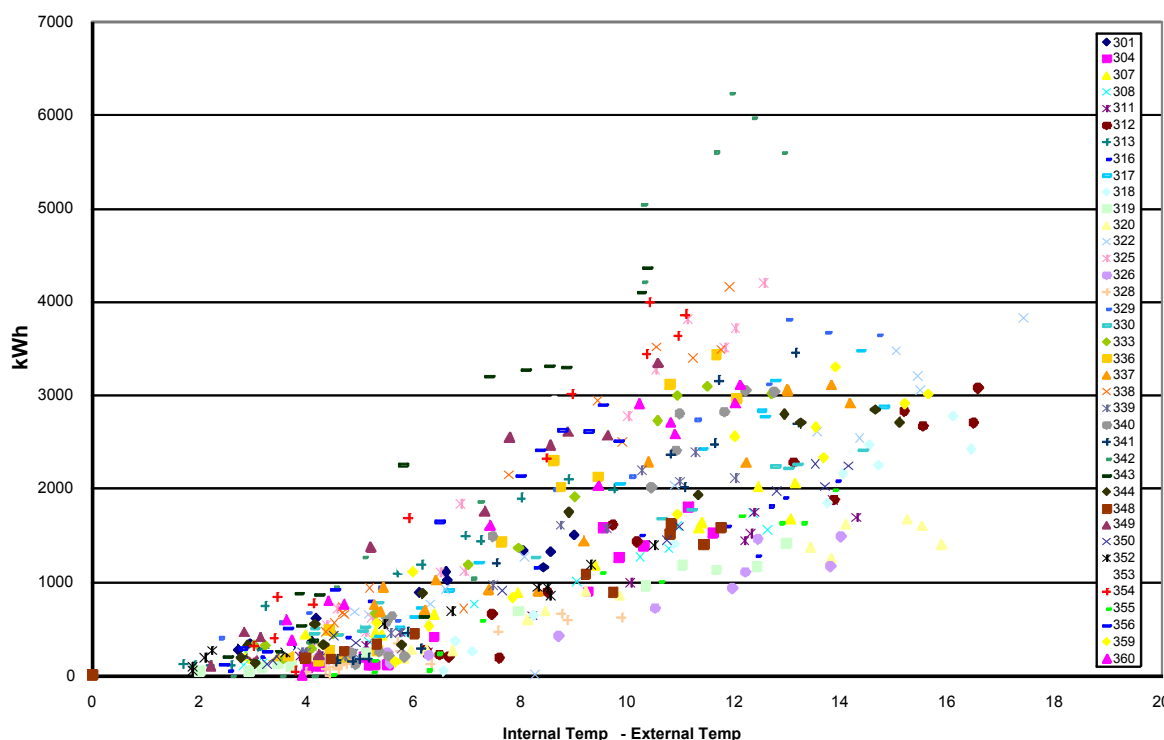


Figure 63 Properties in which reasonable boiler control is observed;  $R^2$  value 0.7 to 0.9.

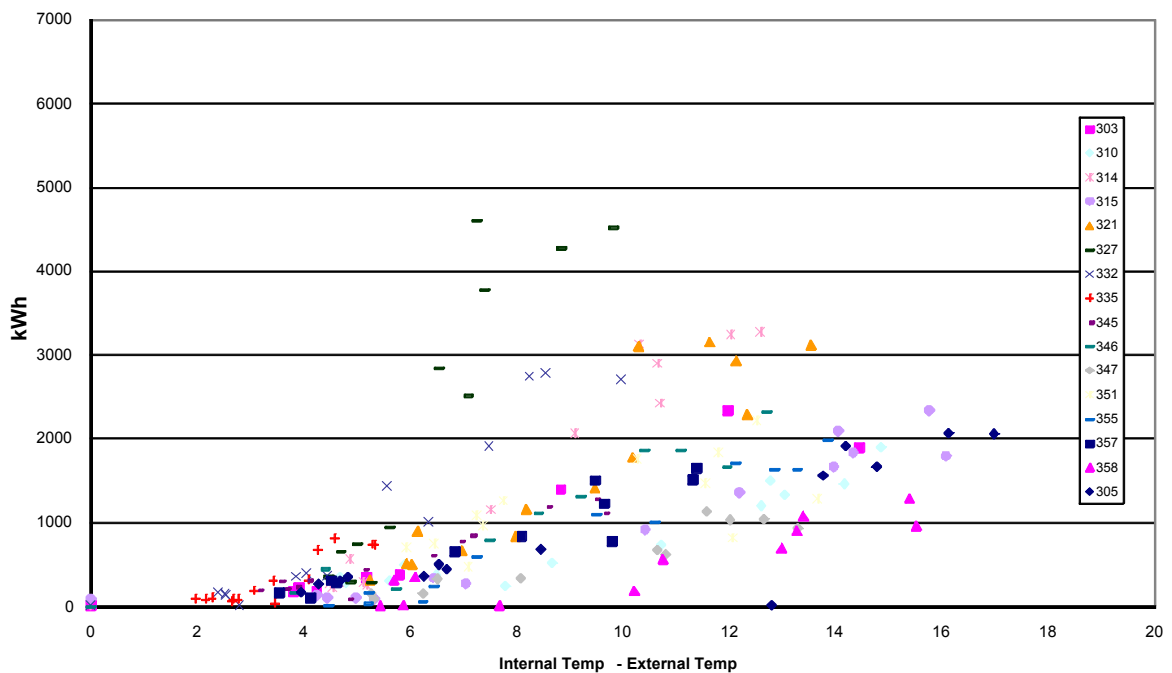
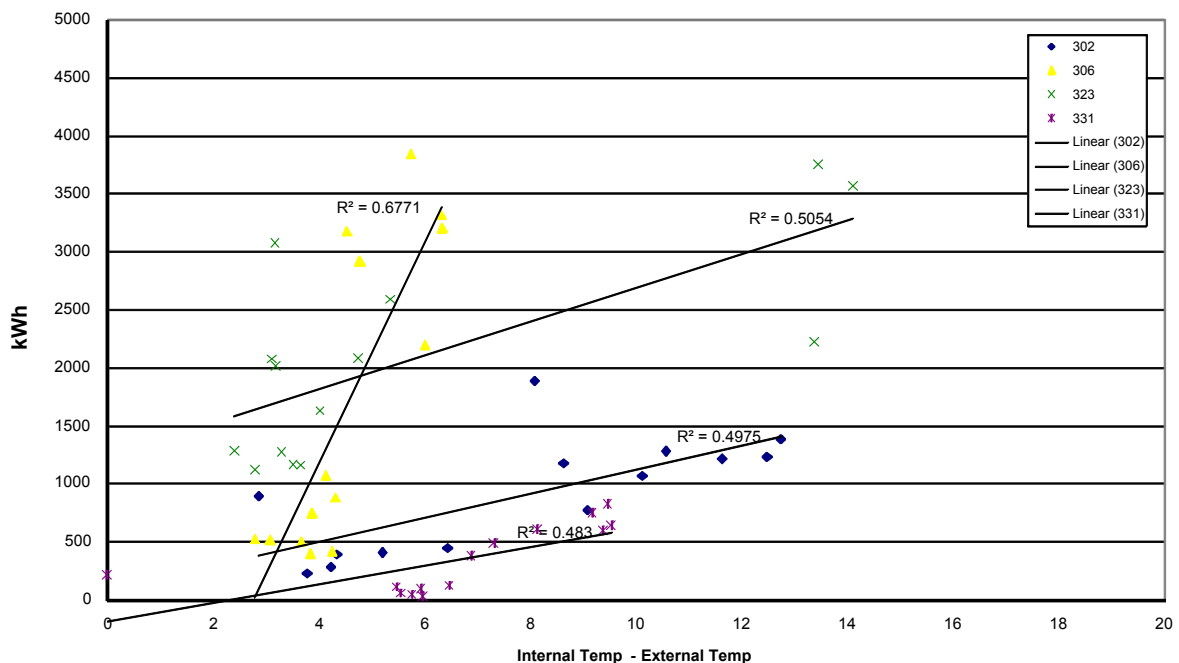


Figure 64 Properties in which poor boiler control is observed;  $R^2$  value 0.7 or less.



The majority of properties show remarkably consistent behaviour, with only 4 displaying truly erratic behaviour. Such observed behaviour may arise from unconventional occupancy such as open windows or frequent visitors. This data can be used to understand routes of energy supply and usage within each house. It could be used in conjunction with further detailed SAP surveys, air change rates and carefully controlled.

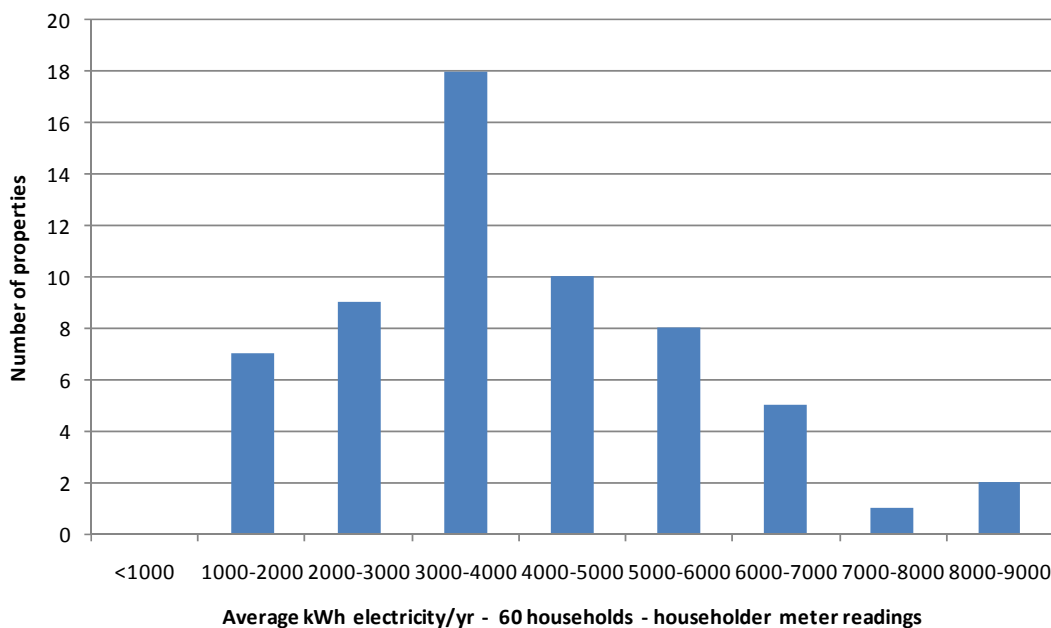
## 7.16 Whole House Fiscal usage

Fiscal data were collected from two sources: householders own monthly meter readings; and pulsed 5 minute data loggers, as described in Section 3.3.

### 7.16.1 Review of householder fiscal electrical data

Householders own meter readings were collected on a monthly basis, although the regularity of collection was variable depending on the householder. 58 of the 60 trial households returned over a year's meter readings, the remaining two returned 11 months of readings. The annual mean electricity consumption was 4055 kWh/yr broadly comparable to the historical UK average, and the median of the data set 3622kWh/yr reflecting the tail of high consumption shown in Figure 65.

Figure 65 Distribution of annual household electrical consumption kWh



### 7.16.2 Review of pulse counter fiscal electrical meter data

Data from the pulse generators were collected at 5-minute intervals. A high frequency of data collection provides good resolution when attempting to identify specific events such as boiling the kettle, using the toaster or having an electric shower. Such relatively short events can be easily 'blurred' when using 30-minute periods for data collection. For example a 2.5kW kettle operating for 3 minutes within a 5-minute data collection period will give an average consumption of 1.5kW, identifiable as short peak load, the same kettle operating for 3 minutes within a 30-minute data collection cycle would only report an average consumption of 0.25kW. This could be confused with (for example) a set of living room lights. Data collection at 30 minute intervals would have made detailed analysis more difficult were the problems the attachment of pulse meters to analogue meters not encountered.

Pulse meter data were compared with householder readings to provide confidence in the pulse meter output. Eight properties were identified where there was good parity between the 5 minute fiscal data recorded by the pulse meters and the monthly consumption data taken from the householders' own meter readings. Average annual electrical consumption of the eight properties for the year varied from 2760kWh to 6850kWh for the eight houses. This compares to a range of 1100kWh to 8300kWh for the whole trial set.

Usage patterns for each property were analysed using monthly colour "tapestries" plotting data recorded at 5 minute intervals (section 7.14). Examples are shown in Figure 67, Figure 68 and Figure 69 of properties 356MJM, 326ABR, and 323RWA respectively plotted for the month of July 08 when there was no or minimal central heating recorded. Tapestries for properties 356MJM and 326ABR highlight the high proportion that 'baseline' electrical consumption makes up of the total load in these two properties although 356MJM has the higher baseline demand of the two and 326ABR the higher evening peak in demand.

Baseline consumption is the relatively constant demand observed between 1am and 5am when residents are asleep. Sources of this demand will include fridge/freezers, internet routers but also standby electrical consumption from televisions, digital boxes, stereos, etc.

These two properties can be compared to the significantly lower baseline and peak consumption of property 323RWA. Figure 66 presents the average annual data from householder electrical meter readings with the three properties in question highlighted. Notably 323RWA, the property with a constantly running boiler pump in January (Figure 58), has half the annual electrical consumption of the other two properties. Boiler pump electrical consumption, compared to other household demands is relatively small.

Figure 66 Plot of annual kWh electrical consumption – Householder readings

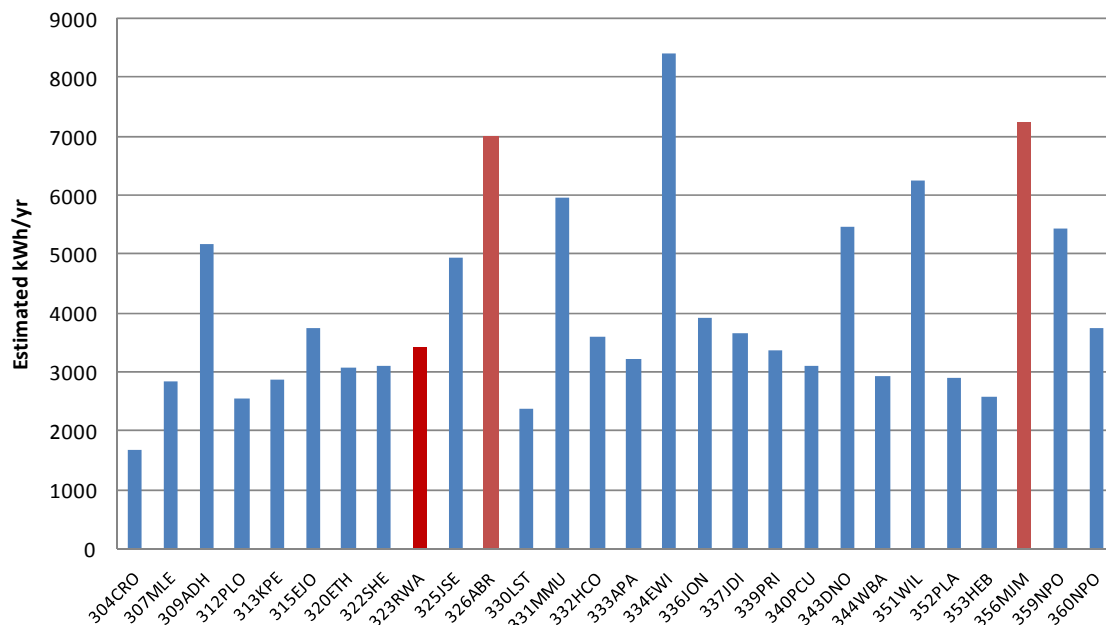
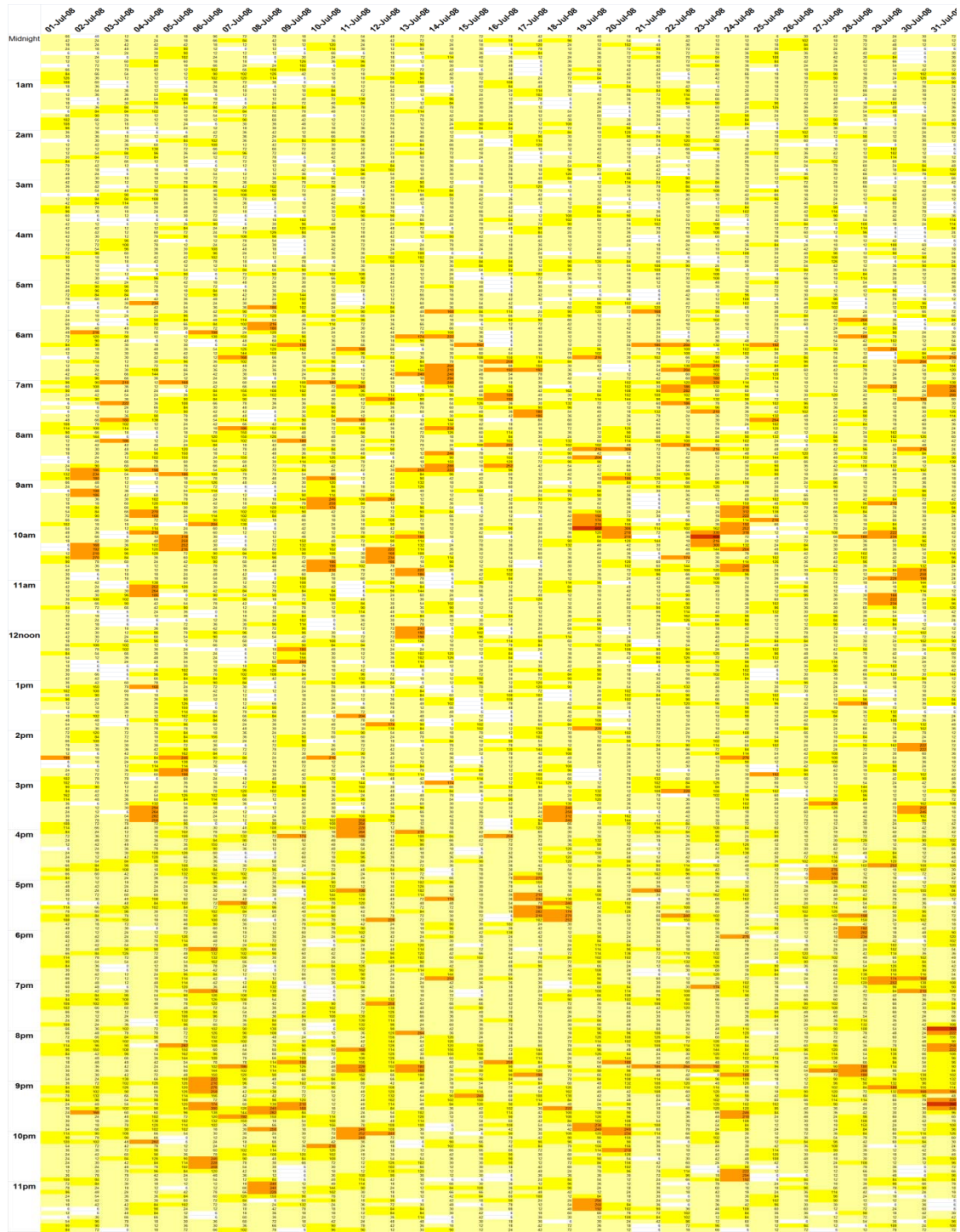




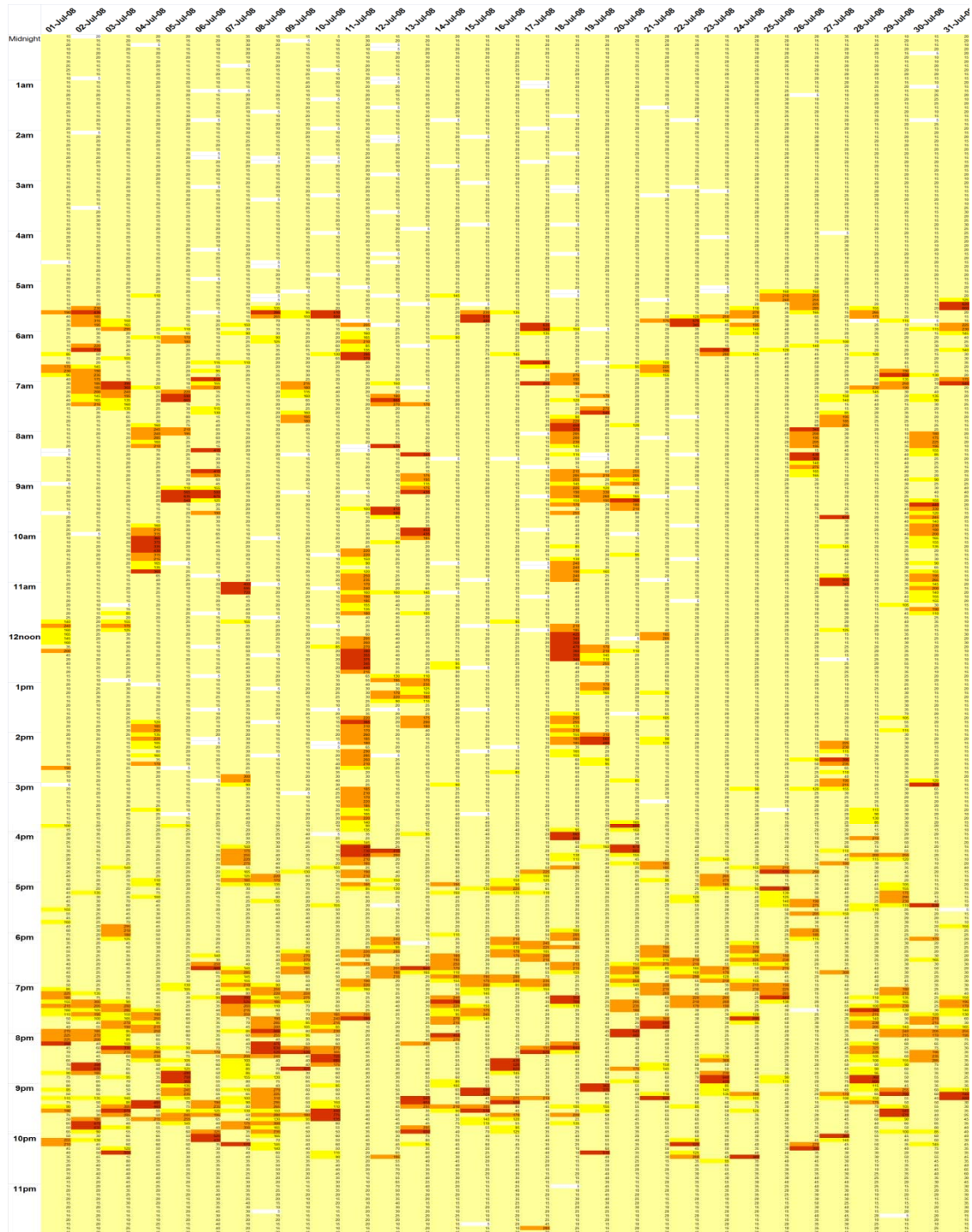
Figure 67: Property 356MJM Tapestry representation of high baseline electricity use- July 08



Key

	Less than 120 W (=10Wh)
	120 W to 1 kW
	1 kW to 2 kW
	2 kW to 4 kW
	over 4 kW

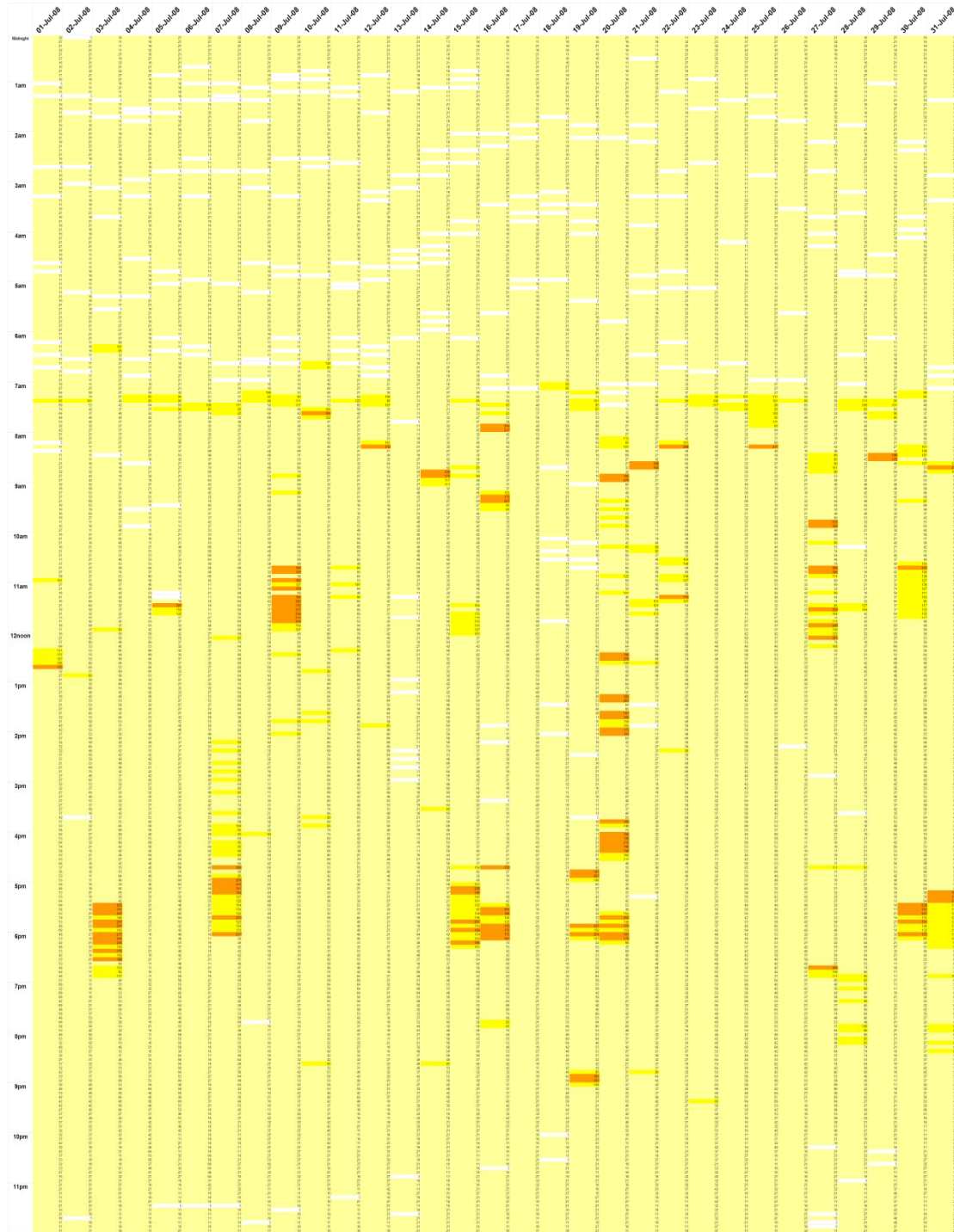
Figure 68: Property 326ABR Tapestry representation of high monthly electricity use – July 08



Key

	Less than 120 W (=10Wh)
	120 W to 1 kW
	1 kW to 2 kW
	2 kW to 4 kW
	over 4 kW

Figure 69: Property 323RWA Tapestry representation of low monthly electricity use July 08



Key

	Less than 120 W (=10Wh)
	120 W to 1 kW
	1 kW to 2 kW
	2 kW to 4 kW
	over 4 kW

Table 17 shows total usage broken down into kWh/month used as:

- “Baseline” (After residents retire to before they rise);
- “Evening Additional” (From arrival home until the residents retire) and;
- “Balance” (difference from the total).

Two values are reported for Annual kWh for each property.

- Annual kWh (sample month x12) - the data from the sample month multiplied by 12
- Annual kWh (Householder average)- the total householder meter readings averaged over 1 year.

Comparison between the two values shows relative consistency indicating that the sample month was not untypical of the property.

*Table 17 Electricity use in kWh/month for selected properties for a sample month*

Property	309ADH	315EJO	320ETH	323RWA	325JSE	326ABR	333APA	356MJM
Sample Month	352	266	181	310	369	417	256	506
Baseline	200	104	95	138	147	138	138	363
Evening Additional	28	54	18	36	54	126	44	0
Balance (e.g. electric showers, cooking)	124	108	68	136	168	153	74	143
Annual kWh (sample month x12)	4228	3187	2172	3720	4434	5009	3069	6068
Annual kWh (householder meter average)	4827	3605	2763	3344	4430	6243	3165	6854

Monthly demands displayed in Table 17 can be seen to vary by a factor of almost three from lowest to highest consumers. The largest variation can be seen in the ‘baseline’ value, which ranges from 181kWh to 360kWh. This baseline demand is surprisingly large. Baseline electricity consumption provides an indication of the number of appliances within the home and what proportion of these are left on standby. Notably property 356MJM shows no discernible evening uplift in demand.

As indicated above, data collection has been difficult but it is suggested that the information does have potential for further analysis and the provision of feedback to the customer. Householder 356MJM could be informed that their baseline electricity consumption was ‘twice the national average’ and was costing them an additional £20-£25 per month, £300 or more a year.



### 7.16.3 Review of pulse counter fiscal gas meter data

Monthly tapestries showing total gas and secondary use were produced for those homes where there was a good correlation between 5 minute fiscal meter data, boiler data and householder readings. Detailed analysis of the data was very difficult due to the method used to estimate secondary usage and the relative size of the loads.

Typical average secondary usage is about 80 kWh per month, which is typical of two hob burners or a hob and grill as might be used to prepare a modest family meal.

Secondary usage was estimated by subtracting the boiler gas usage from the pulse output of the optical readers on the fiscal meters. On a 5-minute basis, this would be the difference between two identical 5-minute periods as measured on the 24 hour clock. Inevitably discrepancies arise between the time registers of the fiscal boiler and gas consumption principally due to the pulse nature of the output. As the secondary use (which might be only a 1 kW hob) is taken as the difference between two large numbers when the boiler is operating at say 24 kW this usage displayed can be erroneous. Even a 25 second error between the fiscal and boiler gas readings will result in the apparent loss of the 1 kW hob. Over a day these errors will balance out. Unfortunately the pulse nature of the technology makes this problem very difficult to overcome.

### 7.16.4 Review of householder fiscal gas meter data

Whilst the above difficulties in identifying secondary gas consumption from the pulse counter data has precluded its use in the analysis of secondary gas consumption there is generally a better correlation between boiler gas meter readings and householder manual readings. For some properties it was possible to identify the amount of gas and electricity used within the property; including the percentage of gas allocated to secondary consumption (cooking and/or secondary heating). This is a complementary approach to the determination of consumption within certain secondary appliances. The following graphs show an example of the data collected from householder readings.

Figure 70 shows the effect of a gas fired Aga stove on the gas consumption of property 314DPA with a notable drop in secondary gas use in February 2008 when the stove is switched off. Following this, very little gas is used for secondary consumption with the boiler gas following the fiscal gas meter readings very closely.

Property 320ETH is occupied by an elderly gentleman who uses his gas fire every day, even during some summer months. Again a strong correlation is observed between the boiler gas use and the fiscal meter readings.

Figure 70 Monthly gas use – property 314DPA

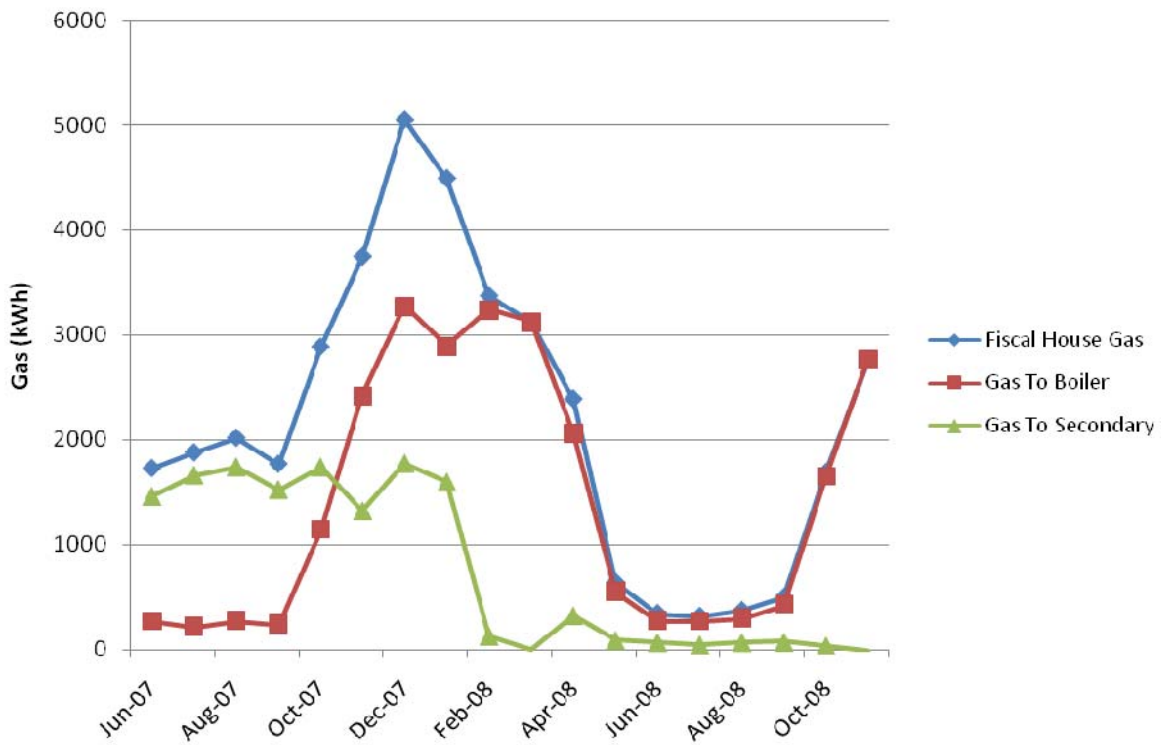
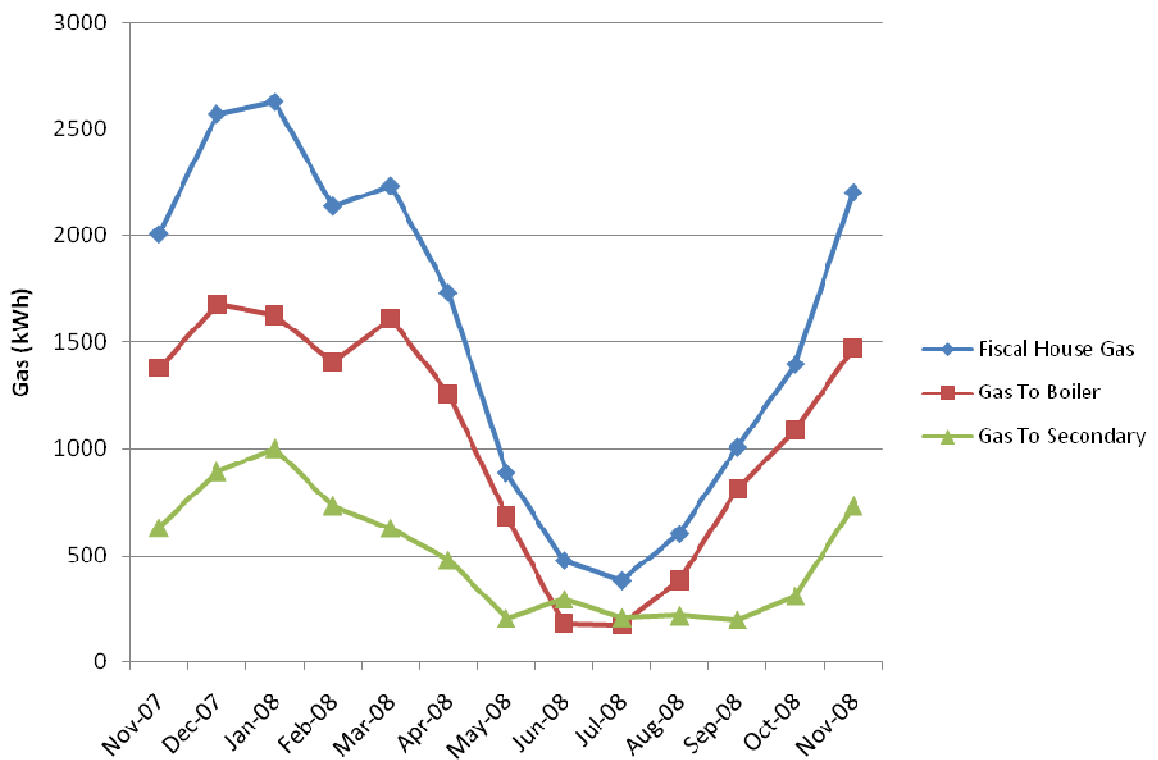


Figure 71 Monthly gas use – Property 320ETH



## 8 Conclusions

Almost all the boilers in the trial performed reliably over the period though due to occupant changes and failure of monitoring or recording equipment, not all sites recorded 12 months of consecutive acceptable data. The main conclusions are based on the results from 43 boilers for which a full 12 month data set has been obtained. This trial sample included 31 combination boilers, 10 regular boilers and 2 CPSU boilers.

### 8.1 Boiler efficiency

Heat efficiency of regular boilers was between 80% and 90% for the majority of months of trial data, with a slight reduction in some sites' performance when less than 500-600kWh heat was supplied per month. Heat efficiency of combination boilers for the heating season was also between 80% and 90% but showed a more marked reduction when less than 1000kWh heat was supplied per month.

Annual heat efficiencies of individual combination boiler sites are distributed between 89.7% and 68.6%. The mean efficiency of the sample set was 82.5% with a standard deviation of 4.0%.

Annual heat efficiencies for individual regular sites are distributed between 89.2% and 81.2%. The mean efficiency<sup>8</sup> of the sample set of regular boilers was 85.3% with a standard deviation of 2.5%. This is significantly less than that suggested by the mean SEDBUK seasonal efficiency of 90.4% (standard deviation 1.1%).

These results suggest that an in-situ performance equivalent to the SEDBUK rated seasonal efficiency is unlikely to be observed amongst installed boilers in this trial sample.

### 8.2 Comparison of trial boiler performance with SAP.

Whilst the calculated trial efficiency of regular boilers can be compared with SEDBUK values when used in SAP, care must be taken in the comparison with trial results for combination boilers as the heat efficiency calculation for regular boilers does not take into account standing losses from primary pipework and hot water cylinders.

The mean of the measured annual efficiencies of the regular boilers in the trials was 85.3% +/- 1.8%. Average of tank and primary pipework losses are roughly estimated from SAP at 1800kWh per year and, if 50% of the losses are useful as space heating on an annual basis, this gives an annual loss of 900kWh. This would reduce the effective overall efficiency of the boiler in terms of useful heat output, by about 5 percentage points based on a typical annual heat output of 15,000kWh. Thus a more valid mean regular boiler annual efficiency may be 80.3 %

Data from combination boilers includes losses associated with rejected hot water which are included separately to the SEDBUK efficiency as a 600kWh/yr loss in the

---

<sup>8</sup> Calculated as (all heat out of boiler)/gas in

SAP calculation. Data on hot water consumption was investigated further to produce a recommendation for the improved calculation of the performance of combination boilers in SAP.

### 8.3 Domestic hot water production

Hot water production was reviewed for summer months alone where no space heating demand was expected. For summer months, the regular boilers were efficient for generating DHW to the cylinder (average heat efficiency 81%) but recorded heat delivered to taps was much lower. The average efficiency of heat delivered to the taps is only 38%, and much lower where little DHW is used (range 13% to 65%). SAP cylinder and primary pipework losses for the three month period are estimated at between 400 and 600kWh while the average heat output from the boilers was 845kWh. Losses from cylinder and primary pipework may be the cause of the low net efficiencies for DHW used for regular boilers.

Poor energy balances have been recorded for combination boilers, especially during periods of low consumption. A laboratory investigation into this found that with very short domestic hot water draw offs, the instantaneous heat to gas efficiency was much lower than expected which was found to be a result of flue loss and heat going to the boiler metalwork, not measured on site. In addition, tests of different tapping cycles found that heat meters used in the trials have a significant delay in responding to changes from zero flow. In heating situations, the long periods of operation make this error negligible, but during short DHW draw offs it becomes significant, resulting in reduced heat flow recorded. Both of these factors led to reductions in calculated heat efficiencies. For the purpose of summer DHW assessment alone, an adjustment of 25% was made to increase heat recorded by the heat meters to attempt to reflect the true situation. After adjustment the combination boilers gave a summer efficiency of 73%. There was a large variation in summer efficiency from less than 40% to above 80%.

It is very difficult to compare the summer performance of the regular and combination boilers due to different measurement points and occasional summer space heating which will have a significant effect on boiler run times and hence efficiencies. Whilst the regular boilers gave an efficiency of 81% in summer, it is estimated that only about half of the heat was used in hot water delivered to the taps, the rest being lost from the cylinder and primary pipework.

In summary, the efficiency of DHW production is dominated by different factors when considering regular and combination boilers. With regular boilers, efficiency is dominated by standing losses; therefore very small **total** draw means poor efficiency. In contrast efficiency of combination boilers is dominated by the length of individual draw offs, thus very small **individual** draw means poor efficiency. It is therefore important to choose a standard draw off pattern when comparing the efficiency of DHW production. Currently SAP uses approximately 100l DHW/day (~5.8kWh) as defined with EU Mandate M324 Table 2 for a 100m<sup>2</sup> property and these investigations show no substantive reason to change this.



#### **8.4 Comparing the annual efficiency of regular boilers with DHW storage, with combination boilers.**

The average of the measured annual efficiencies of the regular boilers in the trials was nearly 3% better than the combination boilers, 85.3% as opposed to 82.5%. The difference is thought to be due to the lower efficiency of condensing boilers when operating in DHW mode (about 73%). When tank and primary pipework losses associated with regular boilers are included a more valid comparison of regular and combination boiler annual efficiency may be 80.3% compared with 82.5%.

#### **8.5 Carbon Benefits Ratio**

The Carbon Benefits Ratio (CBR) includes electricity consumption of the boiler in the calculation of efficiency. The sample of combination boilers had a mean CBR of 78% with a 95% confidence interval of +/-2.1%. This was slightly lower than the sample of regular boilers that had a mean of 82.1% with a 95% confidence interval of +/-1.6%. The difference in electrical consumption may be due to a higher electrical consumption per unit of heat supplied for the combination boilers or may reflect the under recording of hot water consumption.

#### **8.6 Boiler load factor**

Comparing boiler load factor against heat efficiency indicates that heat efficiency is generally independent of load factor above a monthly load factor of approximately 5%. Below 5% there is a slight reduction in heat efficiency for regular boilers and a more pronounced reduction for combination boilers. The majority of data recorded for load factors below 5% relates to summer, hot water led, operation where there is a prevalence of poor data closure.

#### **8.7 Boiler sizing**

There is no apparent correlation between installed boiler size and heat demand, based on heat supplied, assuming the boiler can satisfy demand. If installation guidance relating to boiler sizing was followed, it would be expected that there would be a correlation between these two variables. This lack of correlation supports the view that choice of boiler size is based on decisions by the boiler installer and their beliefs of necessary boiler sizes which may be independent of house size, household usage patterns, and heat loss.

Comparing measured heat efficiency to boiler size ratio indicates that oversizing the boiler does not, on its own, result in a noticeable trend towards a reduced efficiency, for either regular or combination boilers. The reason for this is likely to be that all boilers are "oversized" during most of their operating time, particularly in warmer weather. The peak demand will only occur for short periods of time even with a plant size ratio of 1 and at other times the boiler will modulate and if necessary cycle, to provide the heat demand. Although cycling will incur flue heat loss and purge losses, other factors such as lower return temperatures may improve efficiency.

#### **8.8 Electricity use by boilers.**

There is an overall trend of increasing electricity use with increasing boiler output. There is a wide variation in boiler electrical consumption between installations, with more than a 50% increase in electrical consumption from the lowest consumers to

the highest consumers for the same heat supplied. Boiler electrical consumption in the trial ranges from around 100kWh/year to over 750kWh/year.

80% of boilers recorded annual electrical consumption of greater than the SAP assumption of 175kWh/year. Detailed analysis of electrical and gas consumption of boilers, indicated that a key factor in electrical consumption is the pump operating hours/month which is, in turn, dependant upon the setting of the room-stat, TRVs and other controls. As an example, bimodal heating with an accurately set room thermostat will minimise consumption compared with continuous operation with the room thermostat set to an unreasonably high value. Setting the room stat too high can result in the pump running continuously for the on-period as defined by the time clock. This was observed in some properties in the trial.

Comparing boiler electrical consumption and heat efficiency below 15kWh/month electricity consumption there is a pronounced difference between combination and regular gas boilers in heat efficiency. 15kWh per month indicates an approximate split between heating and non heating seasons. Combination boilers show a greater reduction in heat efficiency without a comparable drop in boiler electrical consumption.

## 8.9 Temperature comparisons.

Analysis of internal and external temperatures indicates that the majority of homes maintain their homes at between 15°C and 22°C over the heating season with a mean for the data set of 18°C. Comparing internal temperatures in living and bedrooms shows that although there are marginally more bedroom temperatures cooler than the lounge, this is not significant and there is no definite trend supporting the SAP assumption that zone 1, the living room, is kept warmer than the rest of the property.

## 8.10 Secondary heating

The use of secondary heating is very variable with some sites using secondary heating appliances during the summer and winter period and some sites not using secondary heating at all, even during colder months.

Annual data from those sites returning secondary heating data indicates that secondary heating use is generally low, on average accounting for approximately 4.1% of the total space heating supplied to a dwelling. The highest consumption is from an electric heater situated in a conservatory, used throughout the coldest months of 2008 (in addition to a gas heater located in the lounge). If the house with heated conservatories is isolated from the dataset, then the recalculated average secondary heating accounted for 3.6% of total space heating supplied. This compares to the current stipulation in Part L1A that secondary heating accounts for 10% of the total delivered space heat for a primary gas heated home.

## 8.11 Conservatory heating

14 of the 60 trial houses featured conservatories. Surveys of householders indicated that 12 of these properties featured some form of electric heating (including oil filled and convector heaters). The internal temperatures of 10 conservatories were monitored and 8 of these were associated with properties that provided 12

consecutive months of accepted data. In 6 of the 8, monthly average temperatures tracked external average temperatures whereas the internal temperatures in the other 2 conservatories tracked internal temperatures. One of these conservatories had monitored electric heating, the other either had a mobile heater or had no thermal separation from the rest of the property.

### **8.12 Modal operation of systems.**

Initial investigation into boiler running times and modes of operation indicated a variety of bi-modal, uni-modal and non standard modes of operation that varied between week and weekend and between sites. This implies that although the BREDEM model does apply to some properties, each householder applies their own decision on how best to heat their house, which may or may not be the most effective/efficient.

### **8.13 System controls**

Given the growing interest in system controls, GaC have carried out 5 minute analysis of usage patterns of control being followed by 4 houses in the trial. A range of control strategies were represented in the sample properties indicating 'text book' and unusual control mechanisms. Gas to water efficiencies of regular condensing boilers appear little affected by the control regime existing within a particular property.

### **8.14 Whole house fiscal usage**

The introduction of whole house fiscal metering has led to a greater understanding of secondary gas use within the home. It has been shown that in a selection of properties where no secondary gas fire is operational, the boiler and fiscal gas meter show very similar consumption. There is also evidence of very variable gas consumption in houses in terms of quantities of gas used, and in terms of amount of secondary heating used.

Fiscal metering of electrical consumption has identified a wide variation in annual consumption with some households having a high baseline of 24hr electrical consumption, and some a low baseline but with higher evening peak demands.

### **8.15 Levels of boiler control**

The level of control has been identified as the level of correlation ( $R^2$ ) between the difference between internal and external temperatures and boiler gas consumed. This has been surprisingly consistent with the majority of householders displaying a reasonably good level of control ( $R^2 > 0.9$ ).

## 9 Recommendations

- For condensing boilers a 'System correction factor' of ~0.95 could be incorporated into SAP to improve the correlation between trial results and SAP predicted performance.
- For **combination** condensing boilers SAP could be amended to differentiate between DHW supply and space heating supply.. Space heating supply should use the standard SEDBUK value and DHW should use the results of laboratory testing during DHW production alone.

Assumptions in Building Regulations Part L1A and SAP regarding secondary heating use should be reviewed in the light of results from the trials. It is suggested that further more comprehensive monitoring of secondary and whole house energy consumption is undertaken.

## 10 Appendices

### 10.1 Appendix A Rules For Data Substitution

1. **Basic premise.** Data shall be accepted unless proved to be defective.
2. **Holidays.** Zero or low closure where there is no gas used, will indicate that the machine is not being used for example during holidays. No substitution should be made.
3. **Very low gas use.** If the '% of Max Input to Engine' factor is less than 4% then this signifies that the machine has not been used a great deal during the 24 hour period and this may result in 'Closure' values outside of Gastec's accepted range.

*In this scenario, data, after close inspection to ensure that all other figures are in proportion, are to be used without substitution as this situation does not signify a fault with the unit or the monitoring equipment.*

4. **Low gas use.** If the '% of Max Input to Engine' factor falls in a range between 4% and 8% then this signifies that the machine has not been used a great deal during the 24 hour period, probably only to generate hot water and this may result in 'Closure' values outside of Gastec's accepted range.

*In this scenario data, after close inspection to ensure that all other figures are in proportion, are to be used without substitution as this situation does not signify a fault with the unit or the monitoring equipment.*

6. **Data transmission problems.** Data relay problems can occur if communication between the site and logging thermostation breaks down. This will result in the data accumulating within the logger's internal memory until either the communications link is re-established allowing all data to 'flow' through or when the logger's internal memory becomes full and starts to overwrite earlier data.

*In this scenario if the data that comes through on the day that the connection is re-established appears to be an accumulation of the missing period (after viewing the principal three i.e. Engine Gas Input, Engine Electric Use, Heat Out, and ignoring those that are calculated i.e. Losses Flue, Losses Case) then the data will be used without substitution.*

*If however it appears that overwriting has occurred then the entire missing period should be substituted.*

*In the event of substitution, the individual days will be left as zero figures because the total figure, i.e. the day the site data came back on line, will cover the missing days. It has been considered that other sites in a similar location could be used to obtain the Degree Day consumption and the 'total' apportioned amongst the missing days appropriately. However, this has been rejected as the potential complexity of the approach is great and the use limited because all engines are assessed on a quarterly or yearly basis.*

7. **Generally** if closure is >90% and <110% then data may be accepted without substitution as this could be caused by monitoring equipment margins combining. However this situation is only acceptable for short periods and this rule cannot be applied for periods of more than a week.

#### **How to substitute – Daily data**

Where several items of important data in a day are missing or unusable, the whole day shall be substituted from that property. If daily substitution is required then data from the previous or subsequent week (but wherever possible with the same Degree Day if recorded) will be used to replace the missing data i.e. a Tuesday will be replaced by the following Tuesday. This substitution takes into account weekends, bank holidays and holiday periods.

An installation that requires large amounts of substitution over a two week period will be referred back to the project team. This is because using the above rule it may not be possible to find appropriate days in the same period with which to substitute.

#### **How to substitute – Column data.**

Where only one column of important data are missing, concentrating on using the principal three data sets; Engine Gas Input, Engine Electric Use, Heat Out, this column **only** can be replaced (if a valid case can be made). This substitution can only occur after a significant amount of data has accumulated to allow the monitoring of trends within the data collection from that property. For example, it is possible to build highly accurate correlations between the gas input, heat out for a particular installation, allowing data to be substituted in the **raw data** for the missing periods.

## 10.2 Appendix B Combination boilers- calculation of case, purge and flue losses

steady state flue 14 W

	seconds	Flue loss %	%*Sec
Pre-purge	8	5	40
Cross light	2	35	70
Combustion	15	20	300
Post purge	30	5	150
			560

Run	Flue loss Steady state	Sec by %	Cycle loss	Total	Theoretical base efficiency	Predicted actual efficiency	Decrease	Combi	Useful heat	No Draw off	Total DHW	GAS IN	Eff %
Secs	%	%*Sec	%*Sec	%*Sec	%*Sec	%	%	30	kWh				
5	14	70	560	630	2200	71.4%	-14.55%	0.18	0.13	19	2.44	3.42	
10	14	140	560	700	2700	74.1%	-11.84%	0.23	0.17				
20	14	280	560	840	3700	77.3%	-8.61%	0.31	0.24				
30	14	420	560	980	4700	79.1%	-6.76%	0.39	0.31				
40	14	560	560	1120	5700	80.4%	-5.56%	0.48	0.38	1	0.38	0.48	
50	14	700	560	1260	6700	81.2%	-4.72%	0.56	0.45				
60	14	840	560	1400	7700	81.8%	-4.09%	0.64	0.53				
90	14	1260	560	1820	10700	83.0%	-2.92%	0.89	0.74	1	0.74	0.89	
100	14	1400	560	1960	11700	83.2%	-2.66%	0.98	0.81				
110	14	1540	560	2100	12700	83.5%	-2.45%	1.06	0.88				
120	14	1680	560	2240	13700	83.6%	-2.26%	1.14	0.96				
150	14	2100	560	2660	16700	84.1%	-1.84%	1.39	1.17				
160	14	2240	560	2800	17700	84.2%	-1.73%	1.48	1.24				
180	14	2520	560	3080	19700	84.4%	-1.55%	1.64	1.39	2	2.78	3.28	
190	14	2660	560	3220	20700	84.4%	-1.47%	1.73	1.46				
200	14	2800	560	3360	21700	84.5%	-1.39%	1.81	1.53				
300	14	4200	560	4760	31700	85.0%	-0.93%	5.14	4.4				
600	14	8400	560	8960	61700	85.5%	-0.43%	5.14	4.4				
1200	14	16800	560	17360	121700	85.7%	-0.18%	5.14	4.4				
2400	14	33600	560	34160	241700	85.9%	-0.04%	5.14	4.4				
3600	14	50400	560	50960	361700	85.9%	0.00%	30.14	25.9				
										Sum	6.34	8.07	78.57%

### 10.3 Appendix C Review of Data closure of Optical readers and householder fiscal meter readings

Data collected from optical readers (pulse counters) was compared with the fiscal meter data collected monthly by the householders. The compared data are represented as a percentage closure calculated from optical data divided by householder meter data. Reasonable closure was considered to be 90-110%.

Comparing householder readings with the gas optical reader data (Table 18) indicates a poor correlation in the majority of households that fitted with optical metering. Of the 33 houses with optical readers on the gas meter, data from only 2 houses achieved reasonable closure for 4 or more months. Optical readers in 19 of the 33 houses indicate higher gas consumption than recorded by the householder, often more than double. In 5 properties the pulse counter had become dislodged and stopped reading any data. In contrast, the householder reading shows good correlation with the boiler gas meter readings (Table 20)

Closure checks on metered electricity (Table 19) indicate about 9 properties with consistent 'reasonable' closure. Usually the automatic device reads high (essentially over pulses). The devices fitted to gas meters performed significantly worse than those fitted to electric meter. The units were installed by more than one individual so it was not a simple training and skills issue. Sometimes this failure was clearly due to mechanical interference by the householder or a professional meter reader, but on most occasions the readings simply diverge; this must be due to a 'malfunction' of the reader but investigations by both the contractors and the suppliers have been unable to offer any credible explanation. The future use of these products cannot be recommended in large scale trials.

Figure 72 Key – Fiscal meter reading closure

KEY
<i>under 80%</i>
80-90%
90-110%
110-120%
<i>over 120%</i>



Table 18 Gas Optical reader data as percentage of meter data collected by householder

Site Reference	Feb-08	Mar-08	Apr-08	May-08	Jun-08	Jul-08	Aug-08	Sep-08	Oct-08
302SWI			850%	532%	663%	1404%	1091%	1202%	5465%
306JYO		156%	112%	107%	108%	124%	97%	63%	67%
308JMA					121%	427%	4184%	2324%	
309ADH			66%	100%	105%	40%	5%	56%	145%
310MPO					813%	1727%	2038%	1840%	733%
311STW	108%	102%	107%	115%	203%	284%	407%	309%	134%
314DPA	464%	550%	610%	1265%	3827%	3437%	1280%		
315EJO		126%	107%	139%	231%	304%	275%	168%	125%
316MBA		160%	142%	152%	307%	325%	292%	348%	134%
317MTR		107%	103%	103%	106%	110%	107%	107%	111%
318BDA				168%	235%	45%	34%	71%	78%
319JBO			5%	1%	5429%	4568%	4405%	7976%	1188%
320ETH				108%	85%	98%	168%	152%	137%
321THB				122%	134%	130%	110%	175%	107%
323RWA				87%	96%	108%	109%	84%	75%
325JSE					975%	1014%	450%	1282%	599%
326ABR				271%	428%	353%	219%	268%	340%
327BSW	77%	88%	90%	87%					
328CHI				282%	1584%	1556%	1266%	680760%	318510%
329PLE			1%	2%	2%	9%	4%		
333APA				2107%	3997%	3992%	3726%	1944%	632%
335RHA	195%	193%	304%	1187%	1597%	1761%	1674%	2279%	703%
342SWA	95%	102%	102%	73%	70%	76%	46%	61%	106%
345PYO			702%	645%	924%	1168%	1169%	950%	423%
346CFR		415%	220%	132%	186%	246%	203%	175%	243%
347WMI				406%	301%	1404%	10228%	9521%	2038%
349JTI			70%	91%	101%	101%	103%	107%	185%
350AWI			75%	113%	123%	145%	137%	177%	117%
354DRO	71%	71%	108%	97%	97%	504%	399%	363%	576%
355PCA	93%	150%	102%	93%	99%	211%	225%	114%	123%
356MJM	139%	134%	115%	175%	1924%	3872%			
357SHO		289%	1001%	4014%	6105%	7406%	4766%	7168%	1938%
358MSC			123%	106%	164%	174%	165%	126%	113%

*Table 19 Electricity Optical reader data as percentage of meter data collected by householder*

Site Reference	Feb-08	Mar-08	Apr-08	May-08	Jun-08	Jul-08	Aug-08	Sep-08	Oct-08
305SWO		95%	139%	133%	151%	120%	115%	113%	
306JYO		141%	142%	153%	170%	178%	164%	152%	145%
309ADH			107%	112%	99%	97%	97%	97%	98%
314DPA	456%	349%	271%	64%					
315EJO		104%	104%	103%	104%	102%	104%	104%	103%
316MBA		55%	61%	66%	81%	78%	89%	86%	68%
317MTR		502%	504%	519%	505%	521%	528%	519%	502%
318BDA				90%	107%	115%	167%	137%	85%
319JBO			55%	391%	564%	613%	782%	403%	141%
320ETH				97%	100%	105%	103%	104%	106%
321THB				194%	297%	262%	163%	153%	127%
323RWA				109%	106%	105%	107%	107%	107%
324PSO					406%	286%	207%	514%	493%
325JSE					162%	108%	106%	140%	123%
326ABR				73%	101%	102%	101%	105%	102%
327BSW	458%	50%	595%	299%	327%	212%			
328CHI				105%	109%	82%	103%	106%	102%
329PLE			562%	705%	871%	707%	473%	567%	619%
333APA				137%	118%	110%	107%	111%	140%
335RHA	154%	113%	107%	21%					
338CNE			107%	61%	8%	2%	2%	2%	27%
341NSM			137%	143%	148%	152%	141%	141%	138%
342SWA	344%	299%	245%	153%	171%	148%	102%	111%	7%
349JTI			105%	99%	99%	100%	98%	99%	101%
350AWI			89%	97%	110%	109%	92%	101%	93%
354DRO	108%	110%	101%	68%	46%	229%	159%	151%	150%
355PCA	686%	620%	573%	379%	398%	106%	37%	142%	205%
356MJM	85%	130%	117%	97%	101%	102%	110%	99%	103%
357SHO		87%	37%						
358MSC			851%	314%	226%	268%	368%	455%	669%

*Table 20 boiler gas meter data as percentage of meter data collected by householder*

Site Reference	Feb-08	Mar-08	Apr-08	May-08	Jun-08	Jul-08	Aug-08	Sep-08	Oct-08
301SPY	101%	101%	91%	125%	58%	86%	112%		
302SWI	98%	79%	149%	47%	108%	82%	48%	107%	94%
304CRO	93%	89%	88%	65%	59%	48%	40%	43%	86%
305SWO	104%	88%	0%	96%	97%	96%	96%	100%	100%
306JYO	102%	100%	99%	96%	109%	91%	95%	96%	100%
307MLE	98%	96%	97%	88%	95%	88%	86%	94%	98%
308JMA	101%	99%	101%	82%	94%	83%	101%	82%	0%
309ADH	102%	97%	111%	60%	72%	69%	64%	66%	87%
310MPO	114%	100%	131%	88%	56%	90%	46%	82%	106%
311STW	106%	95%	97%	89%	83%	83%	86%	90%	92%
312PLO	97%	95%	93%	91%	70%	63%	153%	87%	98%
313KPE	102%	100%	98%	99%	94%	100%	103%	84%	109%
314DPA	96%	100%	86%	86%	80%	85%	81%	85%	98%
315EJO	103%	100%	100%	92%	89%	84%	84%	92%	103%
316MBA	81%	98%	98%	94%	105%	92%	88%	105%	100%
317MTR	98%	94%	94%	90%	82%	79%	84%	93%	97%
318BDA	98%	96%	96%	93%	89%	84%	85%	90%	97%
319JBO	100%	97%	92%	92%	81%	68%	91%	77%	92%
320ETH	66%	72%	72%	77%	38%	46%	64%	81%	78%
321THB	99%	98%	94%	89%	65%	67%	74%	81%	82%
322SHE	217%	98%	97%	97%	94%	91%	91%	96%	100%
323RWA	87%	114%	96%	95%	93%	94%	93%	95%	88%
324PSO	104%	101%	101%	97%	102%	94%	99%	99%	103%
325JSE	76%	76%	70%	49%	32%	27%	14%	49%	65%
326ABR	95%	95%	96%	83%	79%	78%	82%	79%	86%
327BSW	101%	100%	97%	92%	91%	94%	90%	89%	105%
328CHI	76%		103%	111%	96%	80%	138%	113%	95%
329PLE	99%	97%	93%	92%	82%	86%	73%	92%	98%
330LST	109%	104%	98%	103%	93%				
331MMU	101%	101%	102%	88%	93%			101%	109%
332HCO	104%	102%							
333APA	100%	98%	98%	96%	91%	97%	94%	102%	111%
334EWI	136%	102%	101%	104%	92%	104%	94%	96%	107%
335RHA	101%	98%	92%	76%	79%	82%	63%	55%	95%
336JON	103%	94%	101%	91%	81%	86%	94%	97%	86%
337JDI	104%	100%	94%	99%	96%	96%	97%	99%	103%
338CNE	104%	108%	102%	100%	96%	90%	87%	96%	103%
339PRI	102%	103%	102%	94%	98%	99%	98%	94%	102%
340PCU	103%	97%	106%	102%	95%	101%	98%	97%	99%
341NSM	104%	103%	101%	99%	91%	92%	90%	93%	86%
342SWA	99%	95%	94%	77%	94%	106%	93%	96%	89%
343DNO	108%	103%	102%	110%	101%	101%	94%	96%	109%
344WBA	102%	97%	96%	128%	80%	83%	69%	91%	105%

Site Reference	Feb-08	Mar-08	Apr-08	May-08	Jun-08	Jul-08	Aug-08	Sep-08	Oct-08
345PYO	79%	81%	98%	71%	94%	108%	100%	95%	88%
346CFR	91%	98%	97%	94%	83%	87%	87%	88%	98%
347WMI	66%	77%	82%	81%	97%	102%	59%	62%	63%
349JTI	81%	77%	82%	49%	46%	44%	74%	51%	123%
350AWI	95%	106%	99%	98%	93%	99%	97%	99%	101%
351WIL	45%	70%	100%	100%	95%	100%			
352PLA	102%	100%	100%	102%	85%	75%	159%	96%	
353HEB	100%	101%	122%	42%	104%	93%	99%	90%	106%
354DRO	104%	92%	98%	98%	97%	96%	92%	95%	102%
355PCA	95%	93%	92%	61%	69%	82%	79%	78%	95%
356MJM	108%	103%	87%	103%	89%	90%	99%	97%	89%
357SHO	100%	61%	97%	92%	82%	84%	75%	80%	97%
358MSC	97%	100%	113%	74%	92%	107%	102%	81%	97%
359NPO	107%	109%	87%	103%	92%	105%	90%		
360NPO	102%	110%	86%	103%	100%	99%	94%		

## 10.4 Appendix D Summary of data substitution and acceptance

Site Reference	Months accepted with no substitution	Months accepted with some substitution	Number of substituted days (12-month sets only)	% of substituted days per site
302SWI	12	0	0	0%
307MLE	11	1	3	0.8%
309ADH	12	0	0	
310MPO	8	4	11	3.0%
311STW	10	2	2	0.5%
312PLO	12	0	0	
313KPE	12	0	0	
314DPA	10	2	2	0.5%
315EJO	10	2	5	1.4%
316MBA	11	1	1	0.3%
317MTR	10	2	2	0.5%
319JBO	12	0	0	
320ETH	12	0	0	
321THB	12	0	0	
323RWA	10	2	12	3.3%
325JSE	2	10	24	6.6%
326ABR	11	1	1	0.3%
327BSW	6	6	54	14.8%
328CHI	12	0	0	
329PLE	9	3	11	3.0%
331MMU	12	0	0	
335RHA	12	0	0	
336JON	11	1	2	0.5%
337JDI	11	1	2	0.5%
338CNE	12	0	0	
339PRI	12	0	0	
340PCU	10	2	8	2.2%
341NSM	12	0	0	
343DNO	12	0	0	
344WBA	12	0	0	
345PYO	11	1	1	0.3%
346CFR	9	3	8	2.2%
347WMI	11	1	1	0.3%
349JTI	5	7	17	4.7%
350AWI	11	1	1	0.3%
351WIL	9	3	25	6.8%
352PLA	12	0	0	
353HEB	11	1	1	0.3%
355PCA	12	0	0	
356MJM	12	0	0	
357SHO	10	2	13	3.6%
358MSC	9	3	3	0.8%
359NPO	7	5	15	4.1%
43	449	67	225	1.43%

## 10.5 Appendix E Trial Property details

Site Reference	Boiler Type	Heat Loss Coefficient	Design Heat Loss	Type	Age Years	Floor Area (m <sup>2</sup> )	adults	children	Secondary Heating Lounge	Secondary Heating Conservatory / Other	Fuel for Cooking	Controls	Boiler Location	SAP Rating
301SPY	Combi	363	8.0	Semi	131	81	2		Gas Enclosed Gazco Logic E Box, Glue Mounted 2-5kw - occasional		Gas and electric	Programmer/TRVs	Inside	52
302SWI	Combi	156	3.4	Terraced	70	56	2		Gas Wall Mounted - Firelife Model 347 - Rarely Used, Gas fire has been removed, open fire in place, rarely used.		Gas and Electric	Wireless Drayton Digistat RF1 room thermostat, Programmer, 5555	Inside	78
303AMA	Combi	401	8.8	End Terrace	108	85	2	2	none		Gas and electric	Room thermostat/programmer/TRVs	Inside	55
304CRO	Combi	253	5.6	Detached	40	108	2		Gas flame effect fire - never used		Gas	Room Thermostat/Programmer/TRVs	Inside	70
305SWO	Combi	243	5.3	Semi	34	77	2	1	None		Electric	Room thermostat/programmer/TRVs	Inside	72
306JYO	Regular	519	11.4	Detached Bungalow	80	139	3		Gas Fire - Valor Closed appliance - Rarely used getting rid in Autumn to replace with Solid Fuel	Upstairs - Electric storage heater economy 7 - used frequently	Electric	Tank Stat, TRVs, Programmer, 2 Room stats, one in granny annex	Inside	50
307MLE	Combi	271	6.0	Detached	34	124	2		Gas Fire - Open Decorative Camden C2 - Rarely Used	None	Gas	Programmer, TRVs	Inside	81

Site Reference	Boiler Type	Heat Loss Coefficient	Design Heat Loss	Type	Age Years	Floor Area (m <sup>2</sup> )	adults	children	Secondary Heating Lounge	Secondary Heating Conservatory / Other	Fuel for Cooking	Controls	Boiler Location	SAP Rating
308JMA	Combi	252	5.5	Semi		83	1	3	Gas Decorative Fire 1.8-2kw - often used	Kitchen, electric fan heater - often / Utility - Electric halogen 1.2 kW - occasionally	Gas and Electric	Room thermostat/programmer/TRVs	Loft	67
309ADH	Combi	484	10.7	Terraced		124	2	2	Gas Stove Fire - Condemned	Bedroom 1 - Electric winter warm slimline panel heater 0.6 kW (loose Lead) often used. Bed 2 - as bedroom one, but used occasionally	Gas	Room thermostat/programmer/TRVs	Inside	54
310MPO	Combi	209	4.6	Semi	35	95	2	1	none		Gas and Electric	Intelligent control (ex weather compensation) / Room Stat / TRVs	Loft	82
311STW	Combi	275	6.1	Detached	17	134	2	1	Gas Fire - Disconnected - replacing next Autumn	Electric Convection Heater Dragon 2 kW - Occasionally	Gas and Electric	Room Thermostat, TRVs, Programmer	Inside	85
312PLO	Combi	292	6.4	Semi Detached	76	73	2		Gas Fire - never used - condemned	Electric - Glen 2179 2-3kw - used every morning	Gas	Room Stat, TRVs, Programmer	Inside	63
313KPE	Combi	427	9.4	Detached	37	122	1		Gas - Decorative Pebble effect open Fire - Occasionally used	Electric - Oil filled Honeywell H2-470 E - Frequently	Electric	Room Thermostat / Programmer / TRVs	Inside	49
314DPA	Regular	618	13.6	Detached	37	201	2	1	Gas Decorative Fire (no details) 8-9 kW - Occasionally		Gas (aga)	tank thermostat, programmer, TRVs	Inside	48

Site Reference	Boiler Type	Heat Loss Coefficient	Design Heat Loss	Type	Age Years	Floor Area (m <sup>2</sup> )	adults	children	Secondary Heating Lounge	Secondary Heating Conservatory / Other	Fuel for Cooking	Controls	Boiler Location	SAP Rating
315EJO	Combi	270	5.9	Semi	57	129	2		Electric Hot Air used in lounge or dining room - Rarely used. Philips HD 3341/M 2000W	Open log fire in lounge	Gas and Electric	Worcester programmable wireless room thermostat, TRVs,	Inside	79
316MBA	Combi	288	6.3	Semi	45	106	2		Gas Decorative fire - never used	Electric Glen Heater 2kw-used often	Electric	Programmable Digital Room Stat - linked directly to boiler / TRVs	Garage	70
317MTR	Combi	207	4.6	Semi	37	100	2		Gas Baxi Bermuda LFE - used rarely, 5.7kW		Gas	digital room thermostat/programmer/TRVs	Inside	84
318BDA	Combi	204	4.5	Detached House		96	3		Gas flame effect fire - never used		Gas and Electric	Room Thermostat /Programmer/ TRVs	Garage	76
319JBO	Combi	201	4.4	Semi Detached bungalow	40	59	1		Gas Fire - Valor Homeflame - used daily		Gas	Room thermostat/tank thermostat/programmer	Inside	70
320ETH	Combi	172	3.8	Semi	50	74			Baxi Gas flame super - used daily in winter	Electric - Oil Filled - used in extreme weather, Dimplex Rio 13500-1500W	Gas hob, electric oven	Room thermostat/Programmer/TRVs	Inside	85
321THB	Regular	386	8.5	Detached	30	171	2		Gas Decorative Convector - Gazo Holyrood - Used Often, radiant and convector fire, 12.3kW	Electric Glen Heater - Used often	Electric	Room thermostat/tank thermostat/Programmer/TRVs	Inside	74
322SHE	Combi	282	6.2	Detached House	34	122	2		Open fire / smokeless fuel		Gas and electric	Room Thermostat/TRVs	Inside	69



Site Reference	Boiler Type	Heat Loss Coefficient	Design Heat Loss	Type	Age Years	Floor Area (m <sup>2</sup> )	adults	children	Secondary Heating Lounge	Secondary Heating Conservatory / Other	Fuel for Cooking	Controls	Boiler Location	SAP Rating
323RWA	Combi	572	12.6	Semi/terraced	500	128	2		Gas Radiant Fire - used in Very cold weather		Gas and electric	Control on boiler and radiator controls	Inside	43
324PSO	Combi	447	9.8	Dormer Bungalow	100	165	1		Gas fire - Decorative - Paragan Plus 16 NG - Never used	Kitchen - Electric - Water heater, hot water top up for kitchen taps	Electric	Room thermostat/programmer/TRVs	Garage	67
325JSE	Regular	609	13.4	Detached	156	118	2		Lounge - Wood Logs - Villager - Often	Electric Oil Filled Rad - 1.5 kW rarely used	Gas	Tank Thermostat/Programmer/TRVs/Frost thermostat	Loft	39
326ABR	Combi	222	4.9	Semi detached	40	81	3		Flame Effect fire, Kinder Fires Kalahari, 6.9 KW	electric fan heater in bathroom - frequently used	Gas	Wireless programmable room thermostat / TRVs	Inside	65
327BSW	Regular	944	20.8	end terrace	106	197	4		Gas fire - Global Solstice 7 kW - rarely used	Dining Rm - Solid Fuel & Wood Enclosed Stove - Occasionally. Second gas fire in study, never used. Open fire in 2nd lounge, very rarely used.	Gas hob, electric oven. Large range master cooker.	Tank thermostat, room thermostat, programmer, TRVs	Inside	46
328CHI	Combi	136	3.0	Mid Terrace Cottage	126	40	1		Gas Decorative Coal effect open fire - Rarely used	Electric Convection heater - Rarely	Electricity	Room thermostat / TRVs / Programmer	Inside	79

Site Reference	Boiler Type	Heat Loss Coefficient	Design Heat Loss	Type	Age Years	Floor Area (m <sup>2</sup> )	adults	children	Secondary Heating Lounge	Secondary Heating Conservatory / Other	Fuel for Cooking	Controls	Boiler Location	SAP Rating
329PLE	Combi	616	13.6	Detached bungalow	33	151	2		Electric Decorative wall mounted fire 1.5 kW - occasionally	Kitchen - Dual Fuel electric or hot water fan heater 1 kW - frequently / Conservatory has underfloor heating and is independently controlled	Gas	Programmer Room thermostat/TRVs/ Conservatory has underfloor heating and is independently controlled/Pump/ Room Stat/Water Stat	Inside	59
330LST	Regular	220	4.8	Detached bungalow	20	96	2		None		Gas	Room thermostat/TRVs/ Programmer	Inside	81
331MMU	Regular	341	7.5	Semi	73	100	2		Electric fire - Occasionally		Electric	room thermostat	Inside	42
332HCO	Combi	578	12.7	Detached	270	122	2		Electric Decorative stove 2 kW - Rarely used		Electric	Room thermostat/programmer/TRVs	Garage	49
333APA	Regular	447	9.8	Detached House	52	139	2		Solid Fuel (wood) Fires		Gas and Electric	Room thermostat/Tank thermostat/Timer/Clock/TRVs	Inside	61
334EWI	Combi	958	21.1	Semi	102	230	3		Electric Fires		Electric	thermostat, TRVs	Inside	51
335RHA	Combi	627	13.8	Semi	147	204	1		Gas Fire - Rarely Used		Gas	Digistat rfi Wireless System	Inside	59
336JON	Regular	339	7.5	Detached	21	144	2		Decorative Gas Fire - Rarely used		Electric	Programmer Room thermostat/TRVs	Garage	64

Site Reference	Boiler Type	Heat Loss Coefficient	Design Heat Loss	Type	Age Years	Floor Area (m <sup>2</sup> )	adults	children	Secondary Heating Lounge	Secondary Heating Conservatory / Other	Fuel for Cooking	Controls	Boiler Location	SAP Rating
337JDI	Combi	340	7.5	Semi detached	67	85	2		Monitored Electric fire log effect - occasional use (Gas fire - never used)		Electric	Room thermostat, programmer TRVs	Inside	56
338CNE	Combi	309	6.8	Detached dormer bungalow		152	2		Decorative Gas fire - 9 kW - rarely used		Gas & Electric	Room thermostat/programmer/TRVs	Garage	71
339PRI	Combi	445	9.8	Detached	47	112	2		Decorative Gas fire - 6 kW rarely		Electric	Room thermostat/programmer/TRVs	Garage	53
340PCU	Combi	396	8.7	Detached	37	124	3		Gas fire - Rarely used		Electric	Room thermostat/Programmer/TRVs	Garage	59
341NSM	Regular	540	11.9	Semi detached	100	192	4		Gas Fire - not used in years	Electric fan heaters Glen 3 kW - moved around house	Gas	Room thermostat/ tank thermostat/ programmer/ TRVs	Inside	55
342SWA	Regular	591	13.0	Detached	50	252	4		Gas Fire - Log effect used 3/4 weeks per year	Electric Fire - Log Effect - never used. Electric Elite Thermo 60x22" 14.75kW	Electric	Room thermostat / Tank thermostat / programmer / TRVs	Garage	60
343DNO	Combi	663	14.6	2 storey house		173	2		Electric Fire				Inside	54
344WBA	Combi	363	8.0	Terraced	8	125	1		Gas Real flame fire - GOING TO CHANGE	Kitchen - Valor Home flam fire - normally unused	Gas and Electric	Programmer	Inside	53
345PYO	Regular	256	5.6	Detached	27	104	3		Lounge Decorative Gas Fire - Magiglo 6 kW	Electric Oil filled heater - Delenghi 2 kW	Electric	Tank thermostat/programmer/TRVs	Garage	63

Site Reference	Boiler Type	Heat Loss Coefficient	Design Heat Loss	Type	Age Years	Floor Area (m <sup>2</sup> )	adults	children	Secondary Heating Lounge	Secondary Heating Conservatory / Other	Fuel for Cooking	Controls	Boiler Location	SAP Rating
346CFR	Regular	274	6.0	Detached	11	113	2		Decorative gas fire, Magiglo solitaire 8.8kW gross rated input	Electric radiator in conservatory	Gas & Electric	Timer/room thermostat/TRVs	Utility Room	67
347WMI	Combi	216	4.8	Semi	80	87	2		Gas fire - Flavel Misermatic Delux 6.9 kW - used evenings/weekends. Do not find it overly effective	Also have Omicron halogen electric heater 1800W. Not monitored	Electricity	Room thermostat/ Programmer	Inside	79
348HIG	Regular	150	3.3	semi	3	87	2		None		Gas	Timer	Inside	58
349JTI	Combi	381	8.4	Detached Bungalow	40	137	2		Gas real flame fire - used frequently		Gas and electric	Room thermostat/programmer/TRVs	Garage	57
350AWI	Combi	247	5.4	Semi Bungalow	46	78	2		Decorative Gas fire - 9 kW - rarely used	Electric Halogen Heater 1.2 kW & Oil filled heater 2 kW	Electric	Room thermostat/programmer / TRVs (2 broken)	Utility Room	58
351WIL	Combi	248	5.5	Semi bungalow	43	71	1		Electric Fire - Rarely used		Electric	Room thermostat, tank thermostat, programmer TRVs	Inside	64
352PLA	Combi	352	7.8	Semi converted into 3flats	107	89	1		Electric Fire - used 3hrs per day		Electric		Inside	53
353HEB	Regular	379	8.3	Detached	20	178	2		Decorative gas Fire - Cannon 7.0 kW - rarely used	Electric convector heater Tefal 2.0 kW 0 occasionally used	Gas	Programmer Room thermostat/tank thermostat/TRVs	Garage	67

Site Reference	Boiler Type	Heat Loss Coefficient	Design Heat Loss	Type	Age Years	Floor Area (m <sup>2</sup> )	adults	children	Secondary Heating Lounge	Secondary Heating Conservatory / Other	Fuel for Cooking	Controls	Boiler Location	SAP Rating
354DRO	Combi	341	7.5	Semi	36	138	2		Gas flame effect fire - used rarely		Gas and Electric	Room stat / Programmer	Inside	62
355PCA	Combi	247	5.4	Semi-detached	70	75	2		Gas flame effect fires - used in cold weather		Gas and Electric	TRVs	Inside	66
356MJM	Combi	491	10.8	Detached	80	89	3		Gas fire - Verine Fanfare 6.7kW - hardly ever used	Electric Range - Everhot - Always used	Gas and electric	Room thermostat/programmer	Inside	47
357SHO	Combi	180	4.0	Detached	30	77	2		None		Gas	Room thermostat/programmer/TRVs	Garage	87
358MSC	CPSU	166	3.6	Terraced	2	122			None	None	Gas hob, electric oven	room thermostat (next to boiler cupboard), programmer on Gulfstream unit (mechanical timer)	Inside	103
359NPO	CPSU	191	4.2	Terraced	2	122								97
360NPO	CPSU	232	5.1	Detached	2	138								95